

Smart choice for power

xantrex

Join the
hundreds of
dealers who make
the GT 3.0
their inverter
of choice

Make Installations Easy!

The Xantrex GT 3.0 Grid Tie Solar Inverter is easier to install than any other grid tie inverter on the market.

When Xantrex set out to develop the GT 3.0, we listened to the experts – renewable energy dealers and installers. The result is a high performance three-kilowatt string inverter that offers easy installation, superior PV energy harvest, state-of-the-art design and high reliability.

Visit www.xantrex.com/griddie

- ▶ New and improved PV string sizing tool
- ▶ New GT 3.0 service program
- ▶ Free GT 3.0 monitoring software

Xantrex GT 3.0 Inverter

- ▶ 600 volt DC/AC disconnect included
- ▶ Back plate/mounting bracket included
- ▶ LCD display included
- ▶ Wide input voltage (195W - 600W DC)
- ▶ High efficiency 94%
- ▶ 3000W to 40 °C
- ▶ FCC class B noise compliant
- ▶ Compact size with a 5.7" profile
- ▶ 48 lbs total system weight
- ▶ 8 conduit knockouts for easy access
- ▶ Simple multi-inverter installations

www.xantrex.com

THE FUTURE IS BRIGHT FOR THE NEXT GENERATION THE SUNNY BOY 3800 – SMA'S NEWEST INVERTER!

SMA America has designed and manufactured many generations of solar inverters.

Every time, we've worked with solar module manufacturers to develop solar systems that respond to the present needs and future demands of our customers.

Now, we've done it again.

The Sunny Boy 3800U is the newest in our long line of high-efficiency solar inverters.

It's compatible with today's larger solar modules and tomorrow's PV technology. And at 3,800 Watts, the Sunny Boy 3800U can handle the energy needs of a medium to large home easily.

All at a lower cost than ever before.

At SMA, we're dedicated to ongoing research and development into solar technology, so that each generation of Sunny Boy inverters is better than the one before. We're proud to introduce the Sunny Boy 3800U – the next generation in SMA solar inverters... and the best and brightest in the business.

Available Summer 2005 from your local SMA supplier and Solar Pro Club installers nationwide.

Solar Today...
Energy Tomorrow.



WHAT'S THE NEWEST PART OF THIS HOUSE?



THIS

SUNNY ISLAND 4248U
Perfect for off-grid energy, or as
backup power to on-grid systems.

SMA America is pleased to introduce the latest addition to our product line: the Sunny Island 4248U.

The Sunny Island 4248U is a 4,200 Watt commercial grade inverter that's ideal for off-grid systems, or as backup power for on-grid systems. It is the result of years of dedicated research and development, and the finest in solar technology – and it shows.

Built for flexibility, the Sunny Island 4248U can be incorporated into current Sunny Boy systems, or used on its own. And, whether on-grid or off, it does it all at 95% peak efficiency – among the best in the industry.

The Sunny Island 4248U: make it the newest addition to your home.

SMA America, Inc.
12438 Loma Rica Drive
Grass Valley, CA 95945
Tel. 1.530.273.4895
Fax 1.530.274.7271
Email: info@sma-america.com
Web: www.sma-america.com

Solar Today...
Energy Tomorrow.



Plenty of PV Modules. Wind & Hydro Systems. All Balance-of-System Items.

AEE Solar Has It All!

The only one-stop, full-service wholesale distributor you'll ever need!

25-YEARS
of dealer
satisfaction!

Featured this Month



Small PV Modules

Our new proprietary line of 5-, 10-, 20- and 50-watt modules for remote power, telecom and water pumping applications.

NEW!

**AEE
Exclusive!**



Custom-Configured Power Panels

Power panels with Outback, Xantrex or SMA inverters for grid-connected and stand-alone applications.

Grundfos SQFlex Pumps

Solar-powered deep-well pumps deliver 25,000 gallons per day at 25 feet. Can pump from depths up to 500 feet.



**AEE
Exclusive!**

12-Volt Fans

High-efficiency attic/greenhouse fans for battery or array-direct applications.



NEW!

12-Volt LED Lighting

Super-efficient 12-volt flood lamps. Come in three sizes, with an array of either 18, 45 or 99 white LEDs.

Order Online at www.aeesolar.com

Call us for a password and quick demo!

We offer dealers and installers:

- Competitive prices on all the top brands
- Unsurpassed technical expertise
- Widest selection in the business including all items for NEC-compliant installations

2005 AEE Catalog Now Available -

with space for your
name and logo!

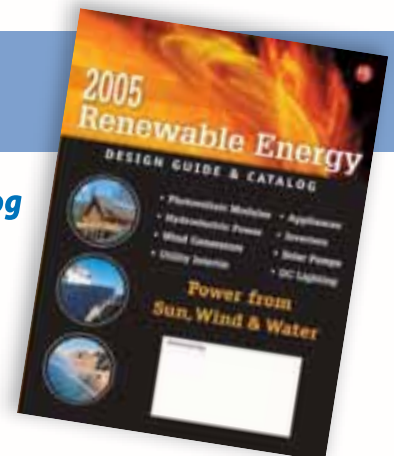

AEE Solar
SUPERSOURCE
Bringing Power to the People Since 1979

formerly Alternative Energy Engineering 

800-777-6609

8:30 - 5:00 Pacific Time, Monday - Friday

www.aeesolar.com

1155 Redway Drive • PO Box 339, Redway, CA 95560
707-923-2277 tel • 707-923-3009 fax • info@eesolar.com

RECYCLED POWER



At U.S. Battery, we're committed to doing our part in keeping the environment clean and green for future generations, as well as providing you with premium deep cycle products guaranteed to deliver your power requirements when you need them.



**DON'T SETTLE
FOR ANYTHING LESS
THAN U.S. BATTERY
PRODUCTS!**



When it comes to shading, we've got you covered.

No matter how much you try, there is no way to avoid shading on the PV arrays. Now, when that shading occurs, you can count on Magnetek Aurora Photovoltaic Inverters. Its two fully independent MPPT tracking channels allow for two arrays with different input voltages and/or planes and array orientations. The result...more energy is harvested during shading.

In addition, Aurora's industry-leading input voltage range (90-600 Volts) permits the use of modules of every power size and voltage. This wide input voltage range allows you to fine-tune your system for different wattage modules and string configurations. The result...more energy is harvested.

Harvest more energy from sunup to sundown with Magnetek Aurora Photovoltaic Inverters.

Call **866-381-2035** or go online at alternative-energies.com/aurora4 for further information.

North America

Magnetek Inc.
N50 W13605 Overview Drive
Menomonee Falls, WI 53051
Phone: (866) 381-2035
Fax: (262) 790-4142
aesales-us@magnetek.com

Europe

Magnetek, SpA
Via S.Giorgio 642
52028 Terranuova Bracciolini, Arezzo, Italy
Phone: (+39) 055-9195-1
or (+39) 055-9195-248
aesales-eu@magnetek.it



*Outdoor with
Transformer*

AURORA PV INVERTERS

*Indoor
Transformerless*



MAGNETEK
UNCOMMON POWER

www.alternative-energies.com

...Or order from these
authorized Magnetek
Aurora Distributors:



(800) 777-6609
www.aeesolar.com



(707) 433-5824
www.dcpower-systems.com



(800) GO SOLAR (467-6527)
www.energyoutfitters.com



(800) 817-6527
www.sunwize.com



(800) 374-4494
www.globalresourceoptions.com

What Do You Need To Get Done Today?

Install a Remote Power System



- Photovoltaics — Large and Small Watt Modules
- The Industry's Leading Brands in Inverters and Inverter/Changers
- Charge Controllers
- Renewable-Power Water Pumping
- Wind and Micro-Hydro Power
- Marine Power Kits
- RV Power Systems
- Racking/Balance of System

Install a Grid-Connected Power System



- Photovoltaic Modules
- The Industry's Leading Brands in Commercial and Residential Inverters
- Solar Power Systems with and without Battery Back-up
- ReadyWatt™ Integrated Systems
- ReadyWatt™ Combiner Boxes, Pass-thru Boxes, and Cables
- Engineering-support, CAD-Drawings
- Racking/Balance of System

Call Energy Outfitters for Selection, Service & Support!

800 GO SOLAR
www.energyoutfitters.com

Call Us For Dealer Referral
Dealer Inquiries Welcome

Grants Pass, OR • Cedar Grove, NJ • Bozeman, MT • Littleton, CO • Calgary, AB • Barrie, ON

Energy
Outfitters

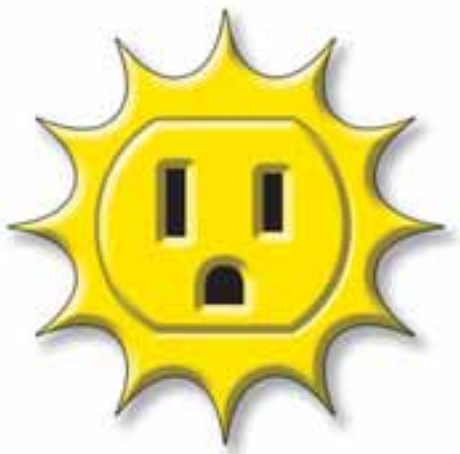

HP108

contents



12 **people's** power

Peter Asmus

For years, residents of two San Francisco neighborhoods suffered pollution from a nearby power plant. Today, they're breathing easier and producing clean energy with their free solar-electric systems.

20 **be** cool

Preethi Burkholder

Beat the summer heat with these basic passive cooling strategies.

28 **step** by step

Joe Schwartz

How to install a pole-mounted solar-electric array—part one, sizing and setting the pole.

36 **good** energy

Dave Evans

Scott and Helen Nearing's legendary Good Life Center lives on, promoting simple living, and now renewable energy too.

44 **Prius** plus

Shari Prange & Dominic Crea

Even cleaner, greener hybrid vehicles may be just around the corner—and nonprofit CalCars is jump-starting the movement.





On the Cover

Joe Schwartz and Anna Bjernfalk raise their final solar-electric panel into place. See page 28 for the first part of a step-by-step article on installing a pole-mounted solar-electric array.

Photo by Shawn Schreiner

Regulars

10 From Us to You
HP crew
Incentives.

86 Code Corner
John Wiles
2008 *NEC* changes.

92 Independent
Power Providers
Don Loweburg
Good energy.

96 Power Politics
Michael Welch
Influencing energy policy.

102 Word Power
Ian Woofenden
Phase.

104 Home & Heart
Kathleen
Jarschke-Schultze
Jefferson secedes.

80 Subscription Form

108 Letters

116 RE Happenings

120 Q&A

122 Readers'
Marketplace

124 Installers Directory

128 Advertisers Index

50 **home** hydro power

Bill Kelsey

Bill Kelsey's homespun microhydroelectric system gets a professional tune-up, and starts producing at its potential.

56 **simple** solar

Chuck Marken

Get your simple solar start with solar batch water heating—an easy, inexpensive, and effective way to use the sun's energy at home.

62 **power** tower

Lisa Kennan-Meyer

Renewable energy rises from the forested depths of the Northwest—the sun and wind pair up to power an island home getaway.

74 **rubber** soul

Gary Duncan

With earth-filled, used tires as its spine, natural plaster for a skin, and passive solar design as its physique, Gary's New Mexico home is all soul.

82 **RE**view

Ian Woofenden

The Flow-Rite Pro-Fill battery watering system makes quick and easy work of a renewable energy system's most tedious maintenance chore.

from us to you

Paying Attention to Production

Chances are that you write a check to the utility company each month for the electricity you use. Most of this electricity is generated using coal or nuclear energy, and these plants are heavily subsidized by our tax dollars. At first glance, installing a solar-electric system may seem to be expensive in comparison to your utility bill, but many states offer attractive financial rebates that make going solar more affordable. Two types of incentives—capacity-based and production-based—can even out the playing field.

Most solar-electric incentives are capacity-based—you're paid a lump sum, based on the size of your system. This approach can be problematic because details like optimal array orientation and siting, and ongoing maintenance can take a backseat to simply installing as many modules as will fit on the roof.

I designed my off-grid system, which was not eligible for these types of incentives, with the goal of maximizing its daily electricity production. I sited my array in the sunniest location on my property, and I pay attention to my system's performance and maintenance. Similar attention to detail is now being rewarded *on grid* with a new and superior incentive model.

Production-based incentive payments are based on the actual output of the system—producers are paid a premium for each kilowatt-hour of clean, green energy produced. Over time, production-based incentives will pay back the original equipment costs. Eventually, the system may even generate income while it produces energy. To help lower initial costs, production-based approaches are often tied to low- or no-interest loans.

Germany's production-based incentive structure has been wildly successful, and is arguably the most effective incentive in the history of the solar energy industry. Washington State recently passed legislation, modeled in part after Germany's, that ushers production-based incentives into the United States on a statewide scale. We're looking forward to the time when other states follow their lead.

—Joe Schwartz, for the *Home Power* crew

Think About It...

*The Sun, the hearth of affection and life,
pours burning love on the delighted earth.*

Arthur Rimbaud (French Poet and Writer, 1854–1891)

Legal: Home Power (ISSN 1050-2416) is published bimonthly for \$22.50 per year at PO Box 520, Ashland, OR 97520. International surface subscription for US\$30. Periodicals postage paid at Ashland, OR, and at additional mailing offices. POSTMASTER send address corrections to Home Power, PO Box 520, Ashland, OR 97520.

Paper and Ink Data: Cover paper is Aero Gloss, a 100#, 10% recycled (postconsumer-waste), elemental chlorine-free paper, manufactured by Sappi Fine Paper. Interior paper is Connection Gloss, a 50#, 80% postconsumer-waste, elemental chlorine-free paper, manufactured by Madison International, an environmentally responsible mill based in Alsip, IL. Printed using low-VOC vegetable-based inks. Printed by St. Croix Press Inc., New Richmond, WI.

HP staff

Publisher Richard Perez
Publisher & Business Manager Karen Perez
CEO & Technical Editor Joe Schwartz
Advertising Manager Connie Said
Marketing Director Scott Russell
Customer Service & Circulation Nat Lieske
Shannon Ryan
Managing Editor Linda Pinkham
Senior Editor Ian Woofenden
Submissions Editor Michael Welch
Associate Editor Claire Anderson
Art Director Benjamin Root
Graphic Artist Dave Emrich
Chief Information Officer Rick Germany
Solar Thermal Editor Chuck Marken
Solar Thermal Technical Reviewers Ken Olson
Smitty Schmitt
Green Building Editors Rachel Connor
Laurie Stone
Johnny Weiss
Transportation Editors Mike Brown
Shari Prange
Regular Columnists Kathleen Jarschke-Schultze
Don Loweberg
Richard Perez
Michael Welch
John Wiles
Ian Woofenden

HP access

Home Power Inc.
PO Box 520, Ashland, OR 97520 USA
800-707-6585 or 541-512-0201
Fax: 541-512-0343
hp@homepower.com
letters@homepower.com

Subscriptions, Back Issues & Other Products: Shannon and Nat
subscription@homepower.com

Advertising: Connie Said
advertising@homepower.com

Marketing & Resale: Scott Russell
marketing@homepower.com

Editorial Submissions: Michael Welch
submissions@homepower.com

www.homepower.com

Copyright ©2005 Home Power Inc. All rights reserved. Contents may not be reprinted or otherwise reproduced without written permission. While *Home Power* magazine strives for clarity and accuracy, we assume no responsibility or liability for the use of this information.



Sav'n'Sun DX Drainback Solar Water Heating System
 Complete kits. Pays for itself several times over its lifetime. Start sav'n now!
Starting at \$1893



SolarMax 240 Solar Air Heating System
 Each kit is recommended for 1000 sq ft of homespace. When heating fuel prices are on the increase, why not use the SolarMax to decrease your fuel demand by 30-50%? Pays for itself in a short 3-6 years! Works with any existing heating system.
\$1649

Rollable Solar Panel



Great for camping. Use for 2-way radios, walkmans, CD players, GPS, other mobile devices. Choose 5, 10 or 20 Watts, 12V. Made in USA.

\$129 to \$415



Miller Gas refrigerators
 Your old 7 cu ft gas fridge too small? We now have larger ones available! Choose from 10 to 17 cu ft. Made in USA.

Prices Start at \$1295



Air-X 400W Wind Turbine PLUS Complete 29' Tower Kit

One great price for everything you need to install an Air-X*. Cable, hardware and even galvanized tubing! Simple to install tower kit requires no concrete and no gin pole. Usually installs in two hours. In-stock and ships UPS. Made in USA



\$999

Southwest Windpower

SUNLINQ™ Foldable Solar Panels

Lightweight, foldable and durable, these mobile modules are designed to charge and maintain your batteries and provide power for your portable electronics including cell phones, PDA devices, MP3 players and laptops. Comes in 6.5W and 12W. Made in USA.

Starting at \$99



Solar Attic Fan
 Great way to keep your attic cool and reduce your air conditioning needs. Easy to install, no AC wiring needed. Runs when it's hot - when there's sun!



\$299

We Have Solar Panels in Stock!
 Brands such as: Evergreen, BP, Sanyo, Sharp & Others
 Call for Info!

MPPT500 500W Solar Charge Controller

Uses high efficiency Power Tracking Technology. Takes inputs up to 500 Watts at 100VDC from solar panel array, and charges a 12, 24 or 48V battery bank. Made in USA.

\$199



MORNINGSTAR CORPORATION

TriStar 45 Amp, 12-48V Solar Charge Controller

Handles solar arrays of up to 4kW, 48V. Includes computer interface for data logging and remote control. Optional digital meter, displays in 5 languages.

Starting at \$143



Excel NE Compost Toilet The Odor-Free Environmental Solution
 The premier non-electric compost toilet used by people living off the grid. Great for cabins, hunting lodges and small homes.

Price Too Low to Show



PVI 2500 2500W Grid-Tie Inverter

Breakthrough in quality & price! Includes display & PC port for free. Lightweight at 35lbs. Unlike other inverters, power is not derated at higher temperatures.

\$1985

The People's POWER

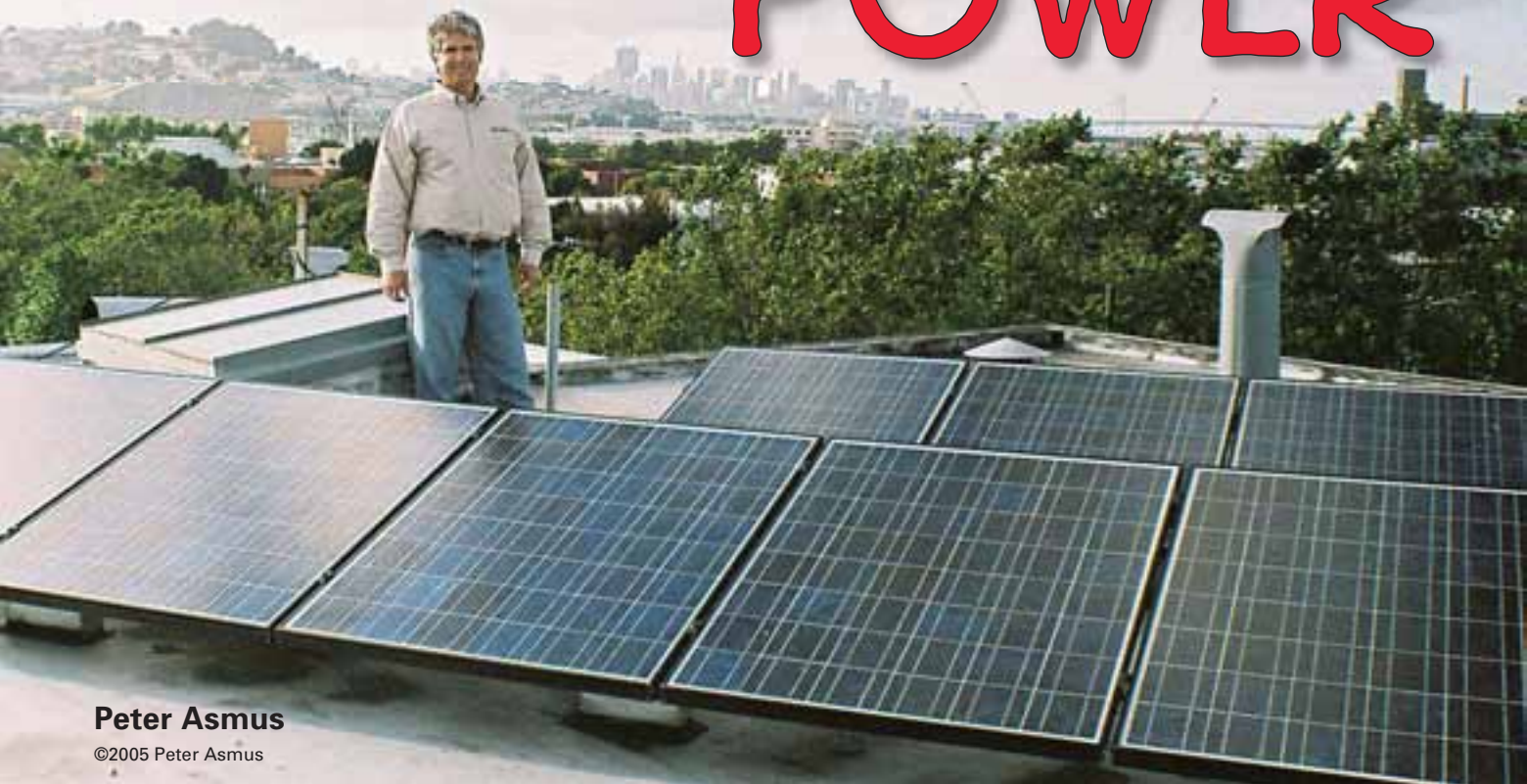

Peter Asmus

©2005 Peter Asmus

Randy Kauffman and his company Next Energy spearheaded the installation of 27 free photovoltaic systems in San Francisco.

After 30 years in the heating and cooling industry, Randy Kauffman switched his focus to solar energy five years ago, establishing Next Energy Corp. in San Francisco. He sensed a great business opportunity, but he also wanted to make a positive contribution to his community and to society as a whole.

That's why he jumped at the opportunity to participate in a special program that provided free photovoltaic (PV) systems to qualifying residents of Bayview and Hunter's Point neighborhoods in San Francisco. The program was part of a settlement negotiated with Pacific Gas and Electric (PG&E) over the severe air pollution caused by their natural gas-fired power plant located near these neighborhoods. San Francisco's Department of the Environment collected

Next Energy Corp. solar technicians, Bernard and Robert Naja, oversaw installation of the systems.



US\$13 million from PG&E that was set aside in a mitigation fund. A key component of this mitigation effort was the release of a request for proposals to install 38 solar-electric systems in the Bayview–Hunter’s Point area.

Think Globally, Act Locally

The Bayview and Hunter’s Point neighborhoods sit on the southeastern edge of San Francisco, hugging the Bay. Here, stuccoed, two-story, single-family homes shoulder factories and businesses. Local residents have suffered from air pollution not only from the nearby power plant, but also from large ships and other industries. Despite pollution problems, this neighborhood is one of the sunniest regions in notoriously foggy San Francisco, making it perfect for PV.

Kauffman was delighted when his Next Energy Corp. won the bid to install 27 systems. “I decided I wanted to make this large-scale solar program a showcase of today’s solar energy technology. This community was the perfect opportunity for my company to demonstrate what a premier solar-electric installation should look like,” says Kauffman.

First priority for the free PV systems was given to residents who had lived in the neighborhoods the longest. Candidates were also evaluated on their participation in social activism within their communities. Finally, and also most importantly, a thorough analysis of each potential site was conducted to determine which candidates’ homes had suitable solar access, ensuring maximum electrical production of the installed systems.

Local citizens were hired to perform these site surveys to make sure that each eligible home had enough space on its roof to install a solar-electric array, and an adequate solar window to justify installing the publicly funded PV system.



Willie Berry (left), pictured with Randy and Dion Kauffman, was one of the 27 recipients who received a rooftop PV system.

A total of six interns completed 180 hours of classroom and field training to perform these assessments. A few, like intern Joe Snell, plan to continue their newfound solar career. “I learned how to do a lot,” he says. “Hopefully I can keep [my career] going...with solar energy.”

Getting It Right

Kauffman took a comprehensive approach to installing the systems, developing sophisticated blueprints for each individual installation and documenting every step in the process. Rarely does an installer get to erect solar-electric arrays on several homes in one neighborhood. Most solar contractors install solar-electric systems on an individual basis.

Instead of completing each system one at a time, the company segregated each phase of the installation process. Crews installed complete array mounts on each rooftop first. Twenty-seven mounts were in place before a single photovoltaic (PV) module was hoisted onto a rooftop. The wiring and inverter placements, and then the installation of the arrays, followed.

“It was quite a challenge installing these systems,” says Jay McLaughlin, vice president and chief technical officer for Next Energy. “Some of these roofs were add-ons. A ‘cookie cutter’ approach would not have worked. On top of that, many of our customers were a bit suspicious. They had concerns about power quality and safety issues. Along with our technical expertise, we had to also be solar ambassadors.”

Aesthetics also played an important role in the design and installation process. Though these homes were often in less-than-stellar condition, Next Energy installers treated each installation with a craftsman’s approach. “I believe the solar-electric industry has to start performing to a higher standard,” says Kauffman. “Our goal was to make these systems showcases of how far the industry has come. And to prove that paying attention to details—and not cutting corners—pays off with better system performance.”

Continued on page 16

PV’s Pollution Savings

The 27 PV systems installed by Next Energy in the Bayview–Hunter’s Point neighborhoods provide pollution-free electricity in a community long plagued by air pollution, and prevent hundreds and even thousands of pounds of pollution from being emitted. Here’s a sampling of savings these systems provide each year:

- 999 pounds (453 kg) of nitrogen oxides, which contribute to urban smog and respiratory ailments
- 594 pounds (269 kg) of sulfur dioxide, a pollutant linked to acid rain and respiratory diseases
- 835,623 pounds (376,030 kg) of carbon dioxide, a primary culprit in global warming



Greg Freeman



Rosalee Pitcher



Ken Jolivette

Debra Franklin



Charles Dacus



The PEOPLE

Money from a Pacific Gas & Electric (PG&E) pollution settlement funded the installation of 27 photovoltaic systems in the Bayview and Hunter's Point neighborhoods of San Francisco.



Bernell Taylor



Besty Bloom Stallenger

Residents who otherwise would not have been exposed to renewable energy technologies were given the opportunity to have their own solar-electric systems, for free! Here are just a few of the excited new converts to clean solar energy.

with the POWER



Maria Piccolomini

Carmen Bannes



Helen Tyner





Next Energy Corp. president Randy Kauffman (far right) and vice president Jay McLaughlin (far left), with interns (L to R) Cyron Byrd, Eric McDowell, Charles Goins, Talafu Grange, and Jacqueline Jones.

Small Details Count

The corrosive effects of the marine environment experienced in these bayside neighborhoods can wreak havoc on a PV installation, says Kauffman. That's where he says paying attention to the small details makes a difference. Next Energy used stainless steel hardware, including the bolts that secured array mounts to the roofs, and all-aluminum racking. Modules with prewired Multi-Contact (MC) connectors ensured tight, weatherproof wiring connections between the PV modules. Each of the 27 solar-electric systems installed in the Bayview-Hunter's Point region also feature a continuous copper ground wire for safety and system integrity.

The 1.1 to 2.3 KW grid-tied systems feature seven or fourteen Sharp 165-watt PV panels married to Sunny Boy 1,800- or 2,500-watt inverters, depending on the size of the array. With an average of 4.72 sun-hours per day, these solar-electric systems crank out from 225 to 357 KWH each month, offsetting most homeowners' electric bills from 40 to 80 percent.

Many Happy Returns

The fortunate ones who received the free solar-electric systems are satisfied customers. "Next Energy did a really great job. They were very professional. I mean that from the bottom of my heart," says Ken Jolivette, a Hunter's Point resident since 1968 and PV system recipient. He used to work near the PG&E power plant, and says that the smell from that power plant was "absolutely putrid." Jolivette is so pleased that he says he's considering expanding his solar-electric system in the future.

Rosalee Pitcher is another longtime resident of Hunter's Point; she's lived in this neighborhood for more than

a quarter-century. "I never even thought about solar electricity," she admits. "I suppose I always assumed that I couldn't afford it." She found out about the program at a regular meeting of senior citizens in the community. "I think it is great that the 'Powers That Be' do something for this community."

Before her 1.2 KW system was installed, her electricity bills averaged US\$80 per month. Her first bill after the system was installed was US\$40. Pitcher participates in PG&E's E-NET program, which allows net-metered customers to spread out savings from their solar-electric systems over the year, subject to an annual reconciliation.

Many of Jolivette and Pitcher's neighbors are envious of their solar-electric systems, and want systems of their own. In fact, because of such strong community interest in solar energy, Next Energy Corp. is working

to create an energy cooperative so other people in the community can afford to put PV panels on their rooftops.

"We'd like to make the Bayview-Hunter's Point community the greenest in the country," says Kauffman. To forward this goal, Next Energy has combined its efforts with the Bank of the West, which is providing financing.

Kauffman estimates that participants would have to pay US\$71 per month over fifteen years to pay off the capital costs. Many residents in this area have monthly electricity bills that are higher than that amount. Kauffman is optimistic that this new co-op could become a model for other communities throughout the country to deliver solar electricity to those with modest financial resources.

Access

Peter Asmus, Pathfinder Communications, PO Box 436, Stinson Beach, CA 94970 • 415-868-9866 • Fax: 415-868-9566 • pthfind@earthlink.net • www.pedrothepathfinder.com

Randy Kauffman, President, Next Energy Corp., 2325 Third St., Ste. 226, San Francisco, CA 94107 • 800-600-8171 or 415-362-4498 • Fax: 415-362-4598 • rekauffman@sbcglobal.net • www.nextenergycorp.com

Sharp Electronics Corp., 5901 Bolsa Ave., Huntington Beach, CA 92647 • 800-SOLAR-06 or 714-903-4600 • Fax: 714-903-4858 • sharpsolar@sharpsec.com • www.solar.sharppusa.com • PV panels

SMA America Inc., 12438 Loma Rica Dr., Unit C, Grass Valley, CA 95945 • 530-273-4895 • Fax: 530-274-7271 • info@sma-america.com • www.sma-america.com • Inverters





Dankoff Solar joins Conergy

**Together with a common vision.
Customer Satisfaction, Integrity, Reliability and Longevity.**

Outstanding service:

- | Excellent customer care
- | Wholesale-only policy
- | Best order fulfillment rate in the industry
- | Automated order and delivery confirmations
- | Outstanding technical support
- | ETL certified power panel integrator

Call for a dealer referral

Toll-Free (888) 396-6611

www.dankoffsolar.com | www.conergy.com



CONERGY



More reliable redundant architecture. More reliable redundant architecture.

Our FRONIUS IG 5000 class grid tied inverters are twice as smart, thanks to the MIX™ Concept – an intelligent control system that produces higher energy yield. And a lot more reliable, because of dual-inverter architecture using redundant power circuits that can work independently.

At a weight of only 42 pounds – less than half the competition – the FRONIUS IG 5100 delivers 5,100 Watts, including built-in DC and AC disconnects to make installation even easier.

You also get user-friendly tools like the informative display and remote monitoring that help make the FRONIUS IG 5000 class the only inverters in their power range with an established track record.

Find out why more than 100,000 FRONIUS IG inverters have been installed worldwide. It's because they really are better than the rest. And you don't have to say that twice.

Fronius USA LLC 5266 Hollister Avenue #117, Santa Barbara, CA 93111
Tel: 805-683-2200 Email: pv-us@fronius.com Web: www.fronius.com



POWERING YOUR FUTURE

Kyocera Empowers Your Future



- Power Range 35-187 watts
- NEW +10% -5% Power Tolerance
- Class 1 Div 2 for KC35-KC120
- UL Listed
- Building Quality Modules Since 1975
- Now Manufactured in North America
- Visit Our Newly Upgraded Website!

The Power of Choice

From our comprehensive family of modules to our 25 year warranty, Kyocera Solar takes a pro-active approach to anticipating the needs of our customers. Call 800-223-9580 or click www.kyocerasolar.com to learn more.

THE NEW VALUE FRONTIER

 **KYOCERA**
KYOCERA Solar, Inc.

Be Cool

Natural Systems to Beat the Heat



Preethi Burkholder,
with Claire Anderson

©2005 Preethi Burkholder

Arbors and trellises, with or without leafy vines, are a great way to cut down on direct sun overheating your home.

If your summer electric bills make you break into a sweat, don't despair. No matter where you live, incorporating passive cooling strategies into your home can increase your personal comfort, decrease your reliance on mechanical systems, and even take a substantial bite out of your cooling bills.

Before air conditioning became mainstream, folks used natural methods to keep their homes cool—funneling cool breezes through open windows, placing fountains in a

center courtyard to provide cooling via evaporation, and building with materials that absorb excess heat during the day. Coupled with heat avoidance techniques such as shading, insulation, and building orientation, passive cooling methods can be used to achieve maximum cooling. They all take advantage of daily fluctuations in temperature and relative humidity, which can be plotted on a bioclimatic graph (see the "Find Your Passive Cooling Path" sidebar). Use this graph to determine which strategies are most effective in your region.

First, Keep Your Cool

Some passive cooling techniques get rid of heat that has accumulated. But *preventing* heat from entering your home in the first place should be your first priority. Sunlight absorbed through your home's roof, walls, and windows

is the primary source of heat gain. You can combat this by using reflective surfaces, high insulation levels, heat-blocking windows, appropriately sized roof overhangs, shading with vegetation and built structures, and properly orienting your home.

Lighten Up. The more heat your home reflects, the cooler it will stay. According to the Department of Energy (DOE), dull, dark-colored exteriors grab heat, absorbing 70 to 90 percent of the sun's radiant energy. Your home's roof admits about one-third of this undesirable heat gain. White or light-colored roofing materials reflect sunlight and stop heat from being absorbed and passed through the attic to the living spaces below.

Studies have shown that improving your roof's reflectance can decrease cooling costs by almost half, depending on how well your attic is insulated. Choose a roofing material with high reflectivity, like white and light-colored



Properly sized overhangs shade windows from the high summer sun, but allow the low winter sun to enter.

Well-positioned trees and shrubs can provide shade for a home's walls and windows.



metal roofs or tiles. Most asphalt and fiberglass composite shingles, even light-colored ones, still absorb quite a bit of solar radiation. With these materials, installing radiant barriers directly underneath the roofing material or in your attic can minimize heat gain through your roof and ceiling.

Tighten Up. Weather-strip and caulk leaky windows and cracks to stop hot air from entering your home. Next, check insulation levels—the more insulation your home has, the better. Insulation is relatively inexpensive, durable, and works year-round. In most regions, the DOE recommends minimum insulation levels of R-49 for attics, R-18 for walls, and R-25 for floors. If you have a limited budget for improvements, most experts agree that spending money to adequately insulate your home's attic is a good investment. Compared to floors and walls, attics are a major contributor to a home's heat gain.

Choose the Right Windows. Whether you're building a new home or retrofitting an old one, choose the highest performance windows you can afford. Windows are prime culprits for letting heat into a home, and can account for up to half of a home's heat gain.

Use double-glazed windows with selectively reflective films, like low-emissivity (low-E) coatings, which

Find Your Passive Cooling Path

The best cooling strategies for your home depend on the local climate. You'll need the following information for your area for each month of the year:

- Average maximum and minimum temperature
- Average maximum and minimum relative humidity (RH)

You can find this information online at the National Climatic Data Center (see Access).

For each month, plot two points on the bioclimatic graph below. The first point is the minimum temperature and maximum RH. The second point is the maximum temperature and minimum RH. Connect the points with a straight line. Each line represents the change in temperature and RH over an average day in that month.

Passive cooling strategies are shown on the chart as overlapping zones. When your lines cross zones, it indicates that this method may be appropriate for your climate. Some months may require using more than one strategy. To minimize expenses, choose one or two methods that are compatible with your home's design.



During the day, interior blinds block the sun. At night, operable windows can be opened to admit cool air.

help block infrared (heat) energy while admitting visible light. In hot and humid climates, argon gas-filled, double-paned windows with a high performance external tint, a low-E coating, and framed with low-conductive materials like wood or vinyl can substantially reduce cooling needs. Climates with hot summers and cold winters require combination films to reflect sunlight in the summer and keep heat inside in the winter.

Make Shade. The simple act of shading your home can decrease indoor temperatures by at least 20°F (11°C). Using vegetation for shade is one of the most successful and attractive shading strategies. Well-placed plants around the home can reduce energy use for cooling by up to 50 percent.

Deciduous trees planted near the home can provide seasonal shade for a home's roof, windows, and walls, and driveway (which tends to concentrate and reflect heat into the house). Trees and other plants placed around the house also help lower the localized air temperature as the leaves intercept heat and remove it through transpiration. But don't plant too close to your home—placing vegetation up against a wall stifles airflow, making your house even warmer, and also can damage siding.

For cooling purposes, the best screening plants are shrubby ones that branch from the base with dense foliage. Shrubs and small trees work well to shade east- and west-facing windows. Some deciduous tree species, such as maples, give good shade in summer while allowing some direct gain in winter.

If passive solar heating is part of your plan, avoid planting trees directly to the south. Even without leaves, branches can create significant shade, reducing your solar gain in the wintertime by 30 to 60 percent. Deciduous vines, planted close to but not up against your home, with their finer branches and winter leaf loss, can create as much

Bioclimatic Graph with Cooling Strategies

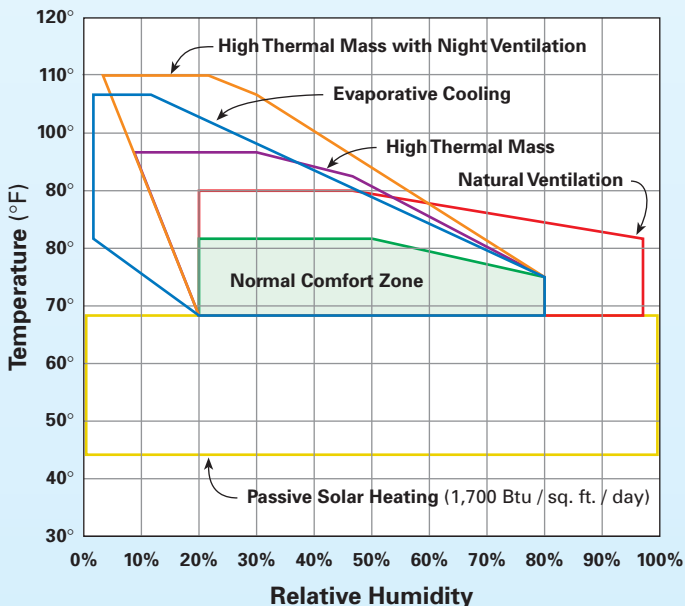

How Overhangs Prevent Overheating

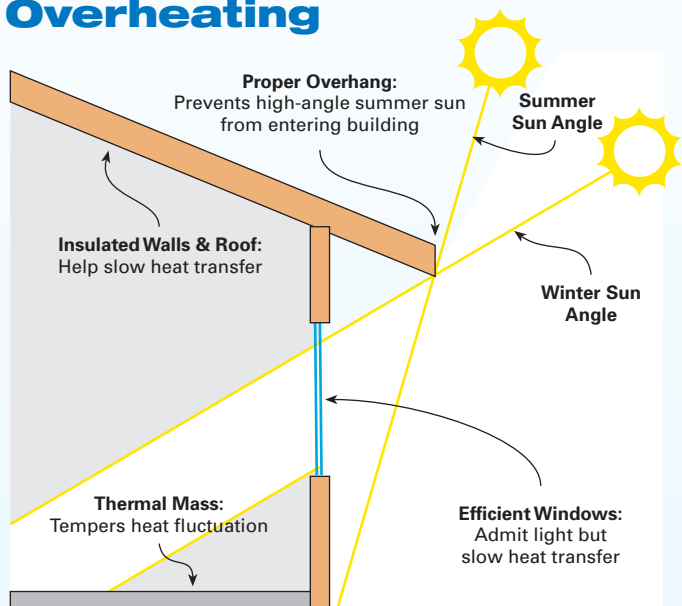

shade in a few years as some trees can in several decades, and may meet your passive cooling and heating needs better than using trees.

Exterior and interior shading structures can also help prevent overheating, although exterior shades are generally superior because they block sunlight before it enters a home. For cooling purposes, overhangs should extend far enough to completely shade windows during hot weather (see illustration above). But if you also want to take advantage of passive heating in the winter, you'll need to design roof overhangs to accommodate wintertime solar gain too.

Another option that fits both summertime passive cooling and wintertime passive heating goals is adjustable overhangs, such as retractable awnings, which can reduce summertime heat gain by at least 60 percent. Seasonal, live

To reduce heat gain, choose light-colored exterior siding and roofing materials that reflect sunlight.



In hot, arid climates, high thermal mass like adobe walls temper heat fluctuations. Small windows on the south wall reduce heat gain.

shade strategies, such as growing deciduous vines on a trellis or pergola, also work well.

Vertical fins attached to the wall on either side of a window block sunlight when the sun is low in the sky and work best placed on a home's east and west walls, although they'll also restrict views somewhat. Other shading options include roll-up shades, which are best mounted on the home's exterior to prevent heat buildup inside the building. Fences and exterior shade walls can be built to shade a bank of windows or a building wall that is especially vulnerable to summertime heat gain.

Plan Ahead. A home's shape and how it's placed on the property can make a big difference in its ability to stay cool. If you are planning to build a new home, take note of the historic building styles in your area—homes in the hot and humid South are built with wide porches, high ceilings, and tall windows to take advantage of convective cooling and to maximize ventilation; southwestern adobes use light-colored, thick clay walls to first reflect, and then absorb the scorching desert sun, and use compact floor plans with few, small windows to minimize heat gain.

Use Airflow to Evacuate Excess Heat

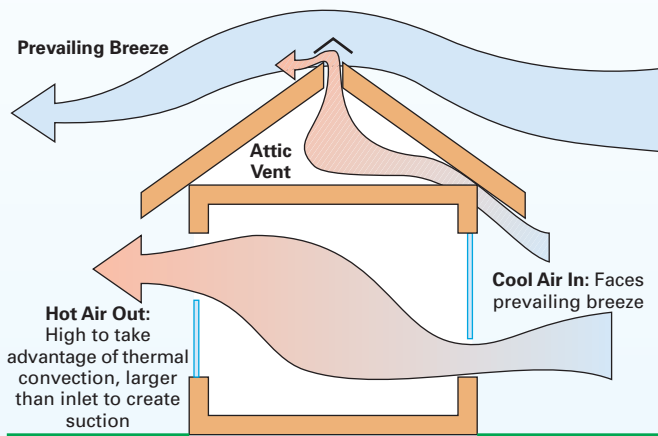

The climate in most regions of the United States calls for summertime shade and wintertime sun. In this case, orienting your home's long axis along an east-west direction is preferable. This allows maximum wintertime heat gain, minimizes the surface area exposed to the low, hot afternoon sun in the summer, and in many cases, takes best advantage of prevailing wind directions for natural ventilation.

Once you've determined the shape and orientation of your home, thermal zoning—coordinating the placement of living spaces based on the building's natural susceptibility to heat gain—can also make your home more comfortable. In extremely hot climates, cluster main living spaces along the cooler north and east sides. Place buffer zones, such as garages, on your home's west side to protect interior living spaces from gaining too much heat.

Passive Cooling Strategies

While heat-avoidance tactics are useful, alone they aren't usually enough to keep a home completely comfortable. But pairing them with passive cooling techniques, which work to actually lower temperatures inside a home, can maximize your thermal comfort and energy savings.

Catch the Breeze. Natural ventilation relies only on the movement of air to cool a home's occupants, usually through open windows. Air movement encourages evaporation from the skin, making you feel cooler and keeping you comfortable at higher than normal temperatures.

Vegetation, such as strategically placed hedgerows, or built structures like fences and walls, can direct prevailing summertime winds into a house. Windows and vents placed on opposite sides of the house help channel these natural breezes through the house by cross-ventilation.

Window design has a great effect on both the quantity and direction of airflow. Double-hung and sliding windows cut airflow by half, and casement windows tend to deflect the air stream from side to side. Horizontal louvered windows, also called *jalousie* or *hopper* windows, still catch breezes but keep rain out. Long, tall windows that open at the bottom and the top may admit cooler air at ground level or vent warm air that's gathered at the ceiling.

When good ventilation is required over large areas of a room, consider using horizontal or strip windows. For comfort ventilation, the operable window area should be about 20 percent of the floor area, with the openings split equally between windward and leeward walls. In general, inlet and outlet windows should be sized similarly. But if more ventilation is needed, a smaller inlet placed opposite a larger one will maximize the velocity of the indoor air stream. To encourage ventilation, create a "chimney" or "thermosiphon" effect by opening windows at the lowest and highest points in your house. Operable skylights and clerestory windows can also foster interior breezes.

Finally, don't forget to air out your attic, which tends to accumulate heat. The DOE reports that ventilated attics are about 30°F (16°C) cooler than unventilated ones. Open stack, turbine, and deflector-type rooftop vents require no electricity and are quite effective.

Cool with Water. Evaporative cooling can be used successfully in arid climates. As water evaporates, the surrounding air temperature drops and relative humidity increases. In hot, dry regions, this rise in humidity actually makes spaces more comfortable. Fountains, pools, and transpiration from plants are all methods of evaporative cooling. Fountains placed in a small, shaded courtyard in the center of the home can provide residents with a place to escape the heat. If that coolness can be captured on an incoming air stream, it can also be channeled to cool interior spaces.

Make It Massive. Materials with high thermal mass—which have the ability to absorb, store, and reradiate heat—work well for passive cooling. During the day, thick walls of concrete, adobe, or brick act as a heat sink, absorbing energy. At night when temperatures drop, the mass slowly releases the heat. For maximum effect, thermal mass must be exposed to the living spaces. High mass buildings have up to 3 square feet (0.3 m²) of exposed mass for each square foot of floor area.

Coupling thermal mass with nighttime ventilation can be a winning practice, especially in hot, dry climates that experience daily temperature swings of at least 30°F (17°C). During the day, windows in the home are closed to prevent excess heat from entering; at night, open windows flush the hot air from the house and cool the mass. For this strategy to work well, operable window area should range from 10 to 15 percent of the floor area.

Attic ventilation is a simple and effective way to reduce temperatures in the whole house.



Dig In. Sinking your home into the earth can offer an escape from the heat. Earth-sheltered homes take advantage of the fairly constant, moderate temperatures of the soil—the ground is cooler than the air in summer, and warmer in the winter.

If you don't want to go underground, a similar effect can be produced with earth berms, which are created by sloping up earth against a home and providing a weatherproofing barrier between. In hot climates, 1 to 2 feet (0.3–0.6 m) of earth can absorb heat and give enough of a time lag to reduce overheating. In these regions, earth berms built on a home's west side are most useful. For maximum effect, berms should be continuous.

Beat the Heat

Charting your climate on a bioclimatic graph and creating a cooling checklist, which lists each strategy and the estimated expense of implementing it, can help you identify the most cost-effective strategies for your home. Even if you can't retire your air conditioner for good, incorporating some of these methods can still save you energy and money—and make it easier to keep your cool.

Access

Preethi Burkholder • preethiburkholder@hotmail.com

Claire Anderson, *Home Power*, PO Box 520, Ashland, OR 97520 • claire.anderson@homepower.com

National Climatic Data Center • www.ncdc.noaa.gov/oa/ncdc.html



PC Software for Sine Inverters
WinVerter™

OutBack Power Systems **xantrex**
www.RightHandEng.com (425) 844-1291

SOLAR COOLING
 WITH
SOLAR CHILL
ULTRA LOW ENERGY
25 TO 130 WATTS!
The most efficient coolers on the planet.
12 & 24 Volt DC Evaporative Coolers
KAR KOOL FOR YOUR VEHICLE



Call SOUTHWEST SOLAR
(520) 885-7925 Tucson, Arizona, USA
southwest-solar.com

Quality First!
SunPumps™ Inc.
 SOLAR PUMPING PRODUCTS

SCS SERIES BRUSHLESS DC

SUBMERSIBLE PUMPS

Brushless DC Submersible Pumps up to 2 HP, heads up to 700 feet and flow rates up to 50 GPM.

SDB SERIES

SUBMERSIBLE PUMPS

Diaphragm Submersibles with heads up to 230 feet & flow rates up to 4.3 GPM.

SCB SERIES

BOOSTER PUMPS

Centrifugal Booster Pumps from 12 volt Home Pressure Systems to 180 volt High Pressure Booster Pump Systems.

SC-P SERIES

POOL PUMPS

Pool Circulating Pumps from 1/2 to 2 HP.

PCA & PCB SERIES

PUMP CONTROLLERS

New Micro-processor based pump controllers up to 3 HP.

Current boosting and voltage boosting models available.

We also manufacture: Jet Pumps
 Triplex Piston Pumps
 Jack Pump Retrofit Kits

For free system sizing, technical support, or to place an order call:

Phone: 1-800-370-8115
 (928) 348-9652
 Fax: (928) 348-9653
www.sunpumps.com

SOLARJACK

 SunPumps stocks all parts and will rebuild any original SolarJack pump or controller.

Not all batteries are created equal!

Rolls ... better by design!

- Modular dual container construction
- Unsurpassed cycling - North America's best
- Widest range of specifications available
- Industry's largest liquid reserve
- 10 year warranty -
15 year average life

Serving renewable energy customers since 1984.

Rolls

BATTERY ENGINEERING

1-800-681-9914

sales@rollsbattery.com



Surrette Battery Company Ltd.

1.800.329.3283

www.earthsolar.com • contact@earthsolar.com

EarthSolar, LLC - 6315 Canyon Dr. - Amarillo, Texas 79110
LOWEST PRICES IN THE NATION!



Southwest Windpower
Renewable Energy Most Simple

Call for Lowest Price
in the Nation
H-40 Turbines

900W (180Kw mo. @ 15 mph avg)
SCALL

H-80 Turbines

1800W (360Kw mo. @ 15 mph avg)
SCALL

AIR X

12, 36, 60 Volt



Call for Lowest Price in the Nation

WHISPER

H-175 Turbines

3000W (600Kw mo. @ 15 mph avg)

"The Most
Powerful Turbine
of Its Class"



bp solar

BP 3125, 125W SCALL

BP 3160, 180W SCALL

SHARP

175W SCALL

**OutBack
Power Systems**

True Sine Wave inverters

EX2024

EX2548

CALL FOR LOW QUOTE

EX2548

CALL FOR LOW QUOTE

MX60 Charge Controller

fully automatic, compatible

with most low voltage

batteries

CALL FOR LOW QUOTE

MATE System

Display/Remote

compatible with

most solar panels

CALL FOR LOW QUOTE

WE HAVE

SOLAR PANELS!

Please call for Panel

Pricing and Availability

UNI-SOLAR

US3, 120W

US5, 180W

KYOCERA

KC120

120 Watts

KC125G, 125Watts SCALL

KC167G, 167Watts SCALL

KC167g

167 Watts

**SHELL
SIEMENS**

SQ80, 12V SCALL

SQ85, 13V SCALL

xantrex



SW4024

SWP102524

CALL FOR LOW QUOTE

CALL FOR LOW QUOTE

CALL FOR LOW QUOTE

CALL FOR LOW QUOTE

CALL FOR LOW QUOTE

Kill A Watt

Call for Lowest Price in the Nation

Call for Lowest Price in the Nation

Call for Lowest Price in the Nation

Call for Lowest Price in the Nation

PRICES SO LOW WE CAN'T PRINT THEM!



SUN-MAR

Excel

Excel NE

Compact

The World's
Largest DC
Surgeprotector
Water Filtration

Call for
Lowest Price
in the Nation

STABER

HXW2304

Super

Efficient

Washer



DGR165 DC

Refrigerator

DGF165 DC

Freezer

DGR225 DC

Refrigerator

DGF225 DC

Freezer

Call for
Lowest Price
in the Nation



Model S-530 SCALL

Model S-460 SCALL

530 AH (100 hr rate)

460 AH (100 hr rate)

12.25" x 7.125" x 16.75"

117 lb (wet), 90 lb (dry)

GRUNDIGER

SQFlex

SCALL

**Dankoff
Integrated
Systems**

SCALL



ProSine

2.5Kw

True Sine Wave Inverters

12 Volt SCALL

24 Volt SCALL

ProSine 1000 GFCI SCALL

ProSine 1000 SCALL

ProSine 1800 GFCI SCALL

ProSine 1800 SCALL

ProSine 3.0Kw GFCI SCALL

ProSine 3.0Kw SCALL

NOTICE!

Services that Earth Solar provides:

If you purchase your system from Earth Solar we provide the following services absolutely free of charge:

- FREE Load Calculation & Design
- FREE Code compliant engineering
- FREE System diagrams
- FREE Phone consultations
- FREE Troubleshooting

Earth Solar provides installation nationally and internationally.

Please call us if you have a project that needs a professional touch.

Package Systems

1.5KW GridTie \$8580
panels, racking,
fusing/disconnects
and inverter

3KW GridTie \$14,760
panels, racking,
fusing/disconnects
and inverter

Residential \$32,500
30) 175W solar modules
OutBack Inverters
OutBack Charge Controller
OutBack Disconnects
racking
Rolls S-460 batteries

Cabin Starter \$2898
2) 120W solar modules
Trace DR Inverter
charge controller
disconnects
rack
4) Rolls S-460 batteries

How to Install...

A Pole-Mounted Solar-Electric Array: Part 1

Joe Schwartz

©2005 Joe Schwartz



If you've decided that a pole-mounted solar-electric array is the best option for your site, here's all the info you need to secure it in the ground for the next 100 years or so.

While groundwork is arguably the least glamorous part of any construction project (it all just gets covered up anyway), it is in many ways the most important. So let's dig into the dirty work required to set a pole for a solar-electric array. In our next issue, we'll show you how to have some good, clean fun mounting and wiring the PVs.

1 *Site the Array*

PV modules are expensive. To maximize the energy produced by your investment and minimize system costs, always look for the sunniest location on your property to install your array. When PV modules are wired at high voltage (48 VDC nominal or more), pole mounts can be located a couple of hundred feet away from the batteries or inverter with minimal transmission losses and relatively small gauge wire.

The best tool for locating the sunniest spot for your panels is a Solar Pathfinder. It takes less than a minute to set up, and will show you when a particular location will be shade-free for every daylight hour, every day of the year. A good solar site should be unshaded from 9 AM to 3 PM, but a larger solar window is always better. Compromises may need to be made. If your site has morning shade but lots of afternoon sun, for example, the site will still be workable, but will likely require a larger array.

The photo at right shows the Pathfinder at the location of my arrays. Year-round, there is no shading between 9 AM and 5 PM. In the summertime, the solar window is even larger, with virtually no shading from 7 AM to 7 PM.





2 Dig the Hole

While working on roofs is never great fun, neither is digging holes. Pole mounts let you skip the roof work, but leave you doing dirt work instead. In some jurisdictions, the building department will require an engineer to specify foundation details that take into account maximum wind loads and soil types for your area. Pole mount manufacturers can also recommend the appropriate hole size for their racks if an engineer isn't required. See the table for one manufacturer's specs.

Because deep, narrow holes are difficult to dig by hand, and impossible to dig with a backhoe, a tractor-mounted auger is the best tool for the job. That said, augers don't work well in rocky soil, and may not be able to drill deep enough for taller poles. The type of ground you're working with will often dictate the actual dimensions of the pole's foundation, and the best way to get it dug. Wooden forms can be built if the hole ends up oversized, but I like to avoid this whenever possible, since it adds time and expense to the job.

At my place, the soil at the array's location consists of 3 feet (0.9 m) of loam and then bedrock. A 5-foot-deep (1.5 m) hole would be impossible to dig without a hydraulic rock hammer, so I expanded the size of the hole to 3 by 3 by 3 feet (0.9 x 0.9 x 0.9 m) deep, using the pole and hole sizing table as my guide. I had a friend with a backhoe come up when I was ready to dig the holes for the mounts. The backhoe made quick work of the holes—in twenty minutes it did what would have taken me two days to do with a shovel.

Pole & Hole Sizing for Top-of-Pole Mounts

Module Area (Sq. Ft.)	Sched. 40 Pipe Size (In.)	Depth In Ground (In.)	Height Above Ground (In.)	Hole Width (In.)
15	2.0	30-36	48-72	8-12
20	2.5	34-40	48-72	10-14
28	3.0	36-42	48-72	12-16
35	3.0	38-44	60-72	12-16
60	4.0	42-48	60-72	16-24
90	6.0	48-60	60-84	24-30
120	6.0	48-72	72-84	24-30
160	8.0	60-78	84-102	30-36
180	8.0	60-78	84-102	30-36
225	8.0	72-84	96-120	36
260	8.0	72-84	96-120	36

Courtesy of Direct Power & Water. Always consult your mount manufacturer for specifications for your site and mount.

or steel suppliers, and is typically sold in 21-foot (6.4 m) lengths. Usually, your supplier will cut the pipe to length for a nominal fee.

Aesthetic and practical considerations will affect pole height. In my case, I want the arrays fairly low so I can reach to brush snow off in the winter. Others choose a taller pole to allow people, animals, and lawnmowers to pass underneath unscathed, or to improve solar access.

If you require a taller pole than the standard specified height, you will need to have more pole in the ground. For each extra foot (30 cm) that you add above ground, you'll want approximately 6 more inches (15 cm) in the ground in concrete. If you have to go more than 2 or 3 feet (0.3-0.6 m) higher than what is shown in the table, a larger diameter pole may be necessary—consult your rack's manufacturer.

In windy conditions, a significant amount of stress is put on the pole's concrete foundation due to the surface area of the array. At a minimum, the pole should be drilled or cut to allow for the insertion of two rebar crosspieces in the concrete. Use 18-inch (0.46 m) pieces of 1/2-inch (13 mm) rebar running perpendicular to the pole (see photo on the next page). If the concrete mixture and curing process is less than perfect, some shrinking of the concrete can occur. The two crosspieces of rebar will keep the pole and the attached array from rotating in the hole during high winds.

Locate the holes for the two rebar crosspieces by measuring up from the base of the pole. For 1/2-inch (13 mm) rebar, I use a 5/8-inch (16 mm) drill bit and a high power AC drill to cut the holes. Run the drill at low speed, and use cutting oil to prolong the life of the bit and keep it running cool.

3 Pipe Selection & Preparation

The diameter of the pole required for your installation will be specified by the pole mount manufacturer, as will the hole dimensions. Pipe sizes will range from 2 inches in diameter for small arrays, up to 8 inches for large arrays. Keep in mind that pipe sizes go by the inside diameter of the pipe. Make sure to double-check that the outside diameter of the pipe is correct for the pole mount you're purchasing.

Pole mounts are most often designed to rest on schedule 40 steel pipe, but large arrays or tall poles may require thicker walled, schedule 80 pipe. Consult your mount manufacturer for the right pipe for your array. The appropriate pipe is almost always available locally at wholesale plumbing warehouses

4 Position, Anchor & Plumb the Pipe

The 6- or 8-inch poles used for larger arrays are heavy, often weighing a couple of hundred pounds. When positioning the pole, it's good to have at least two people on site. Instead of just you and your back doing the job, enlist the help of a friend. If the hole has a narrow diameter, insert the rebar crosspieces before you position the pipe in the hole. There may not be sufficient clearance to do it once the pole is lowered into position.

After installing dozens of pole mounts, I've come up with a simple and inexpensive method to temporarily anchor the pole in a vertical position while I'm getting everything lined out for the concrete pour.

Run two, 8-foot (2.4 m) 2 by 4s flat along the ground on either side of the pole. Drill out the ends of each of the 8-footers using a $\frac{9}{16}$ -inch (14 mm) drill bit. Then cut four, 18-inch (46 cm) pieces of $\frac{1}{2}$ -inch (13 mm) rebar, and hammer the rebar through the drilled holes, securing the long 2 by 4s to the ground. Cut two shorter lengths of 2 by 4 (18 inches is usually perfect). Get the pole roughly vertical (plumb) and fasten the shorter 2 by 4s to the longer ones, snug against the other two sides of the pole to form a square hole with the pole in the middle. Use screws for easy removal of the lumber once the concrete has cured.

Plumb poles look good. Out-of-plumb ones don't. Once the pipe is anchored in place, use a 4-foot (1.2 m) carpenter's level to plumb up the pole in two directions. Place the level vertically on the south-facing side of the pole, plumb it up, and then check the east side of the pole. You'll need to check for plumb in each direction several times, since the pole will typically move a bit while you're making your adjustments.



5 Install Rebar & Conduit

If your local building codes require engineering for the pole mount's foundation, the size and spacing of the rebar will be provided to you, and you just need to follow the engineer's specifications. At a minimum, always install rebar crosspieces as described earlier. Use rebar tie-wire to hold the rebar in place while the concrete is being poured.

After the rebar is in place, drill a hole in the bracing and position the PVC conduit for the PV wire run before the concrete is poured. The conduit can be temporarily fastened

to the pipe with the same type of tie-wire you used for the rebar. Choose the diameter and type of conduit based on *National Electrical Code (NEC)* specifications. The conduit will run down the pole to a 90-degree fitting and then out beyond the edge of where the concrete will be poured. Some installers use Unistrut to clamp the conduit to the pole once the concrete is cured. If you choose this approach, make sure to use spacer blocks or pieces of Unistrut to set the conduit at the correct distance from the pole.

In most locations, electrical inspectors require all aboveground PVC conduit runs to be schedule 80 PVC. This conduit has a thicker wall than the schedule 40 PVC that is typically used in trenches, and will better resist physical damage. Take a look at *NEC* sections 352.10(F) and 352.12(C) or section 352.2 in the *NEC Handbook* for more info on this requirement. Some installers prefer to use rigid metallic or EMT conduit for extra protection on exposed, outdoor conduit runs.

I'm installing data acquisition sensors on the PV arrays at my place to measure irradiance (the sun's intensity), wind speed, and ambient and PV module temperatures. This is why you can see a second, smaller, conduit run in the photos. Most systems will simply have a single conduit run coming down the pole.



Project Overview

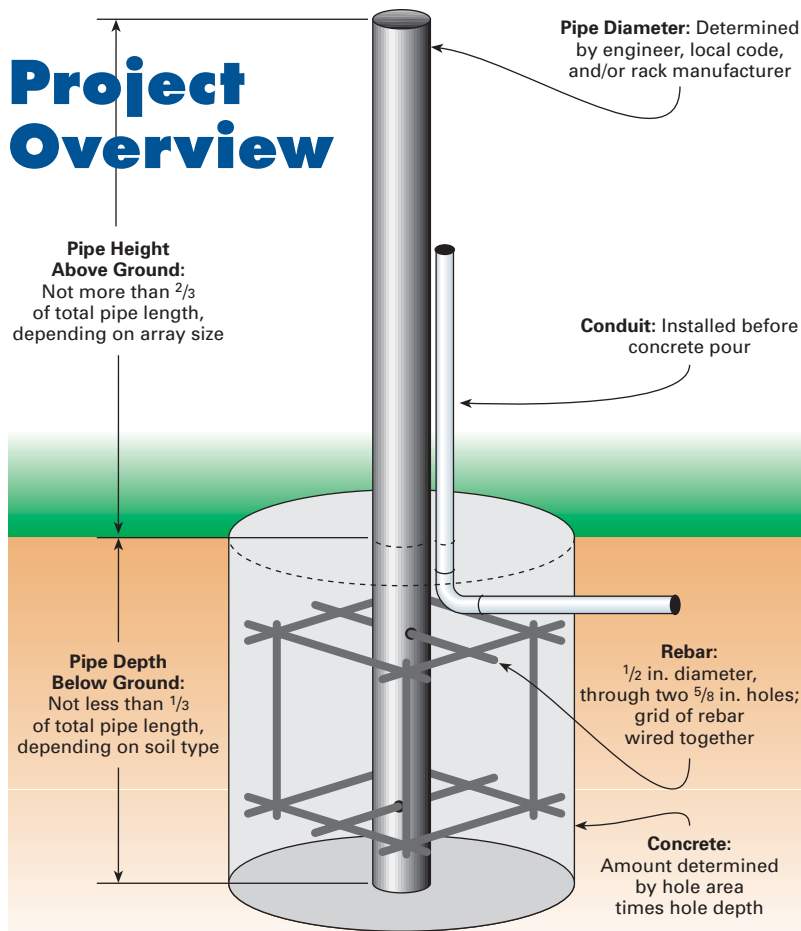

6 Estimate the Amount of Concrete

The amount of concrete required to secure the pole for your PV array will vary depending on the size of the PV array, the soil type, the pole's height, local wind loads, and the dimensions of the finished hole. Deep, narrow holes will require less concrete than wider, shallower ones.

You can determine the amount of concrete required by calculating the volume of the hole. The volume will equal the surface area of the hole times the depth. For square holes, the equation is $L \times W \times D$ (length \times width \times depth). For round holes, the equation is $\pi \times R^2 \times D$ (Pi \times the radius squared \times depth). Pi is a mathematical constant that always equals approximately 3.14. Finally, a cubic yard of concrete equals 27 cubic feet.

Let's run through the math required to calculate the amount of concrete required for two different hole sizes. The two holes my friend with the backhoe dug at my place are 3 feet by 3 feet across, and 3 feet deep. Each hole required one cubic yard of concrete ($3 \times 3 \times 3 = 27$ cubic feet or 1 cubic yard). If the holes had been round, and were 2 feet in diameter (1 foot; 0.3 m radius) and 5 feet deep, they would have only required 15.7 cubic feet of concrete ($\pi \times 1^2 \times 5 = 15.7$). To convert this to cubic yards, simply divide by 27 ($15.7 \div 27 = 0.59$ cubic yards).

7 Get the Concrete

There are a few different options for getting concrete for the pole's foundation. You can buy bags of ready-mix concrete and mix them on site. For larger holes, this can be both expensive and labor intensive. A 90-pound (41 kg) bag of ready-mix will make approximately $\frac{2}{3}$ cubic foot of concrete. So a 3- by 3- by 3-foot hole would require about 40 bags of ready-mix ($27 \div 0.66$). That's a lot of concrete to mix in a wheelbarrow, but definitely doable. However, there are easier ways to go about getting the job done.

Many rental yards now have towable, 1-cubic-yard mixers. If you or a friend has a truck that's set up for towing, this is a great option. The mixer is filled at the rental yard with concrete and water. The mixing cylinder is trailer mounted and includes an engine that mixes the concrete while in transit, keeping it ready for the pour. This approach can be cost effective, and is definitely labor saving compared to purchasing, hauling, and hand mixing 40 bags of ready-mix.

Another option is to have a cement truck deliver and pour the concrete. While this is definitely the easiest way to go about it, it's usually going to be the most expensive. Many pole mounts only require a cubic yard of concrete or less. Typical commercial trucks are sized to haul 9 yards, and concrete companies will usually hit you with a short load charge if you need fewer than 3 yards delivered. In addition, if your site is a ways out of town, transport charges usually come into play. So unless you're installing multiple poles, or have the need for additional concrete, calling in a truck usually isn't your best bet.

My immediate needs for concrete included 2 cubic yards of concrete for the pole mounts (one yard for each hole), and 3 cubic yards for the slab floor of the power shed I'm building—5 yards total. Since my property is only 25 minutes out of town, simply calling in a truck made a lot of sense.

8 Pour the Concrete

Wooden forms are usually not needed when pouring a foundation for a pole mount. The sides of the hole will contain the concrete, keeping it where you want it. I like to pour the concrete to within an inch or so of the top of the hole, and then backfill over the top of the cured concrete with soil and some grass seed. To my eye, this looks the best.

If you want the concrete to be exposed, a simple form built out of 2 by 4 lumber placed at ground level over the hole, and secured with rebar, will allow you to pour and finish the top of the exposed foundation. You can also use a cardboard tube form (Sonotube) or thin plywood bent into a circle.

Immediately before you pour the concrete, grab a hose and wet down the bottom and sides of the hole. This will keep the soil from drawing moisture from the concrete as it cures. When pouring the concrete into the hole, make sure to direct the chute or shovel away from the pole to minimize the chance of knocking the pole out of plumb. Always make sure to double-check the pole for plumb immediately after the pour, since slight tweaking is often required.

Make sure to give the concrete ample time to set up before you begin installing your PV array. The surface area of the installed array will act like a sail in windy conditions, and may move the pole out of plumb if the array is hastily installed before the concrete is sufficiently cured. Ideally, I like to wait five days before I begin installing the array. If you're working within a tight time frame, a day or two should be sufficient, depending on the ambient temperature during curing.



*The completed pole—
next issue, installing the
solar-electric panels.*



Finishing Touches

Finally, I like to paint the pole to prevent surface rust and keep it looking sharp for years to come. Talk with the folks at your local hardware store for info on prepping the pole for paint, and the best paint to use. Using galvanized pipe is another solution, costing less time, but more money.

In our next issue, I'll guide you through assembling the pole mounts, and installing and wiring the PV array and combiner boxes. Until then, get digging, or better yet, find a friend with a backhoe.

Access

Joe Schwartz, *Home Power*, PO Box 520, Ashland, OR 97520 • 541-512-0228 • joe.schwartz@homepower.com • www.homepower.com

Solar Pathfinder, Rte. 1, Box 260-1, Linden, TN 37096 • 317-501-2529 • Fax: 931-589-5400 • info@solarpathfinder.com • www.solarpathfinder.com

Pole mount manufacturers:

Array Technologies Inc., 3312 Stanford NE, Albuquerque, NM 87107 • 505-881-7567 • Fax: 505-881-7572 • sales@wattsun.com • www.wattsun.com

Direct Power & Water, 4000-B Vassar Dr. NE, Albuquerque, NM 87107 • 800-260-3792 or 505-889-3585 • Fax: 505-889-3548 • dirpowdd@directpower.com • www.directpower.com

General Specialties, 206 N. 4th Ave., #200, Sandpoint, ID 83864 • 208-265-5244

UniRac Inc., 3201 University Blvd. SE, Ste. 110, Albuquerque, NM 87106 • 505-242-6411 • 505-242-6412 • contact@unirac.com • www.unirac.com

Zomeworks Corp., 1011 Sawmill Rd. NW, Albuquerque, NM 87104 • 800-279-6342 or 505-242-5354 • Fax: 505-243-5187 • zomework@zomeworks.com • www.zomeworks.com



POWER-FAB

QUALITY HARDWARE FOR THE PV INDUSTRY



Designed for the Professional...

- Top-of-Pole Mounts**
- Power-Rail Mounting System**
- Side-of-Pole Mounts**
- Power Tube Commercial Racking System**
- Power-Grid Racking System**
- Roof-Ground Mounts**
- Battery Boxes, Racks and Cabinets**
- Equipment Enclosures**

Preferred by Experienced Installers



DIRECT POWER AND WATER CORP.
ALBUQUERQUE, NM USA
 800-260-3792 OR 505-889-3585
 FAX: 505-889-3548
www.power-fab.com
info@power-fab.com



- A diverse line of quality trackers for: Grid-Intertie, Commercial Applications, Remote Homes and Water Pumping.
- Trackers from 150 W to 15 kW.
- Complete pre-engineered TrackKits™ available.
- Patented technology.
- 15 years of solar tracking experience.

Array Technologies, Inc

505-881-7567

www.wattsun.com

ZOMEWORKS CORPORATION
 RELIABLE PASSIVE ENERGY PRODUCTS SINCE 1969

**NEW TO ZOMEWORKS TRACKERS:
 THE UTRK040**

- Improvements from UTR040 include:
- Light weight for quick installation
 - Early morning wake-up fin for fast response
 - Dual shock absorbers for better stability
 - Ships partially assembled via UPS



UTRK040 installation by Total Light & Power Pie Town, NM

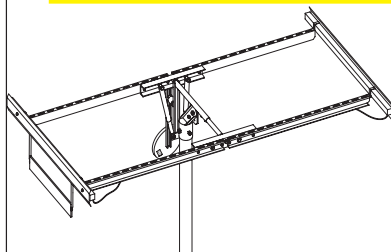

California Building Code certification available for all racks

NEW UTRF168 now comes standard with high wind kit, please call for pricing



UTRF168 photo Installation by Miller Power and Communications Atascadero, CA

WWW.ZOMEWORKS.COM
 800-279-6342

80 Years of Building Better Batteries

- Performance engineered for durability, reliability and maximum capacity
- Flooded or valve-regulated (VRLA) products
- Live technical support or visit www.trojanbattery.com
- Trojan is the world's #1 manufacturer of deep cycle batteries for renewable energy systems



Available from Master Distributors Worldwide
800-423-6569 • www.trojanbattery.com
Trojan - Clean energy for life™

VENA QUAD DISPLAY PANEL METERS

AC/DC MONITOR

VENA

BAT 1

13.2 VDC 3.40 A

120 VAC 60 Hz

ALARMS ON

ALARM SETUP (CONFIG (HOLD)) DISPLAY MODE ALARM ON/OFF (EXIT (HOLD)) LIGHT (POWER (HOLD))

With Alarms!

Measures:

- DC Voltage
- DC Current
- AC Voltage
- AC Frequency
- AC Current
- Temperature
- Time

Features:

- User Selectable Alarms
- Backlighting
- Large Display

*Shown actual size

Vena Engineering Corporation

831.724.5738

<http://www.vena.com>

Wholesale to the Public since 1998.

Systems Design Engineers answer Your call

800-810-9939

affordable solar

Lowest Prices Under the Sun!

Sun Frost
19cu.ft AC
Refrig/Freezer
\$2,399



Crystal Cold
18cu.ft Propane
Refrig/Freezer
\$2,099

Servel Americana
RGE 400 8cu.ft Propane \$1,029

SunDanzer
8cu.ft Battery Powered Refrig.
or Freezer \$949

Solar Chill
Evaporative Cooler
2424HP \$936



Featured This Month



KC187G	187W	W/MC connectors	\$749
KC167G	167W	W/MC connectors	\$669
KC125G	125W		\$519
KC120	120W		\$499
KC80	80W		\$335
KC70	70W		\$292
KC60	60W		\$264
KC50	50W		\$229
KC45	45W		\$219
KC40	40W		\$199



3000 Watt Gridtie Solar
Electric System \$14,359



SX170B	170W	24V	\$785
SX160B	160W	24V	\$739
BP3160B	160W	24V	\$799
BP3125J	125W	12V	\$599
BP380U	80W	12V	\$379



Shell Solar

Shell 175-PC	175W	24V	\$805
Shell 165-PC	165W	24V	\$749
Shell 85-PC	85W	12V	\$399
Shell 80-PC	80W	12V	\$369



NT-175U1	175W	24V	\$769
ND-167U1	167W	16V	\$679
NE-165U1	165W	24V	\$695
ND-L3EJE	123W	12V	\$539
NE-80EJE	80W	12V	\$369

Uni-Solar Solar Panels

US64	64W	12V	\$319
------	-----	-----	-------

Complete Systems

1.3kW Solar Electric System for
Off Grid Remote Home \$11,499



TriStar TS-60 60 amp-hr \$199



EC-102	12/24V	\$428
EC-110	12/24V	\$479
EC-115	12/24V	\$499



Smart choice for power

Inverters-SW Plus Series		
SW4024 Plus	4000W	24V
Series II		
SW4024	4000W	24V

Call for Sale Price



Sunny Boy 6000U
Sunny Boy 2500U
Call for Sale Price



Surrette Batteries

S-460		\$189
S-530	6V 530 amp-hr	\$209



VFX3524	3500W	24V
GVFX3648	3600W	48V
MX60 MPPT Charge Controller		

Call for Sale Price

Solar Water Pumps

Grundfos SQ Flex Pumps **Call for Sale Price**
ETAPUMP Submersible Pumps

Sun-Mar Composting Toilets

Excel NE \$1,075



Southwest Windpower

12V & 24V 400W Wind Turbine \$535

Prices Subject to Change.

Featured Brands

visit www.affordable-solar.com



KYOCERA Solar, Inc.



MyGeneration



isoton



Shell Solar



Located in sunny Albuquerque, New Mexico! (505) 244-1154 * sales@affordable-solar.com

Good Energy

at the Good Life Center



The solar-electric system helps demonstrate the Good Life Center's commitment to sustainable living.

Scott and Helen Nearing showed generations of homesteaders how to live in a peaceful, sustainable way. During their 60 years of living on the land in rural New England, they wrote about their commitment to social and economic justice, and shared their homesteads with visitors. The Nearings' philosophy and lifestyle has been recognized as a focus of America's "back to the land" and "simple living" movements. Many *HP* readers may recall Scott and Helen's books, *Living the Good Life* and *Continuing the Good Life*, which each sold hundreds of thousands of copies.

Over several decades, the Nearings grew their own food in organic gardens, built handcrafted stone buildings, and tried to live simply and sustainably on the land. In 1952, they moved to Harborside, on the Maine coast, where they built their second stone home, now known as the Good Life Center (GLC).

Scott Nearing died at age 100 and Helen at age 92. A board of stewards now runs the homestead and, each year, selects two resident stewards to live there to continue the Nearings' work in the garden and in the community. Monday night meetings and weekend workshops explore spiritual, economic, social, political, and practical matters related to simple living. Between 1,500 and 2,000 people visit the Center each year.

Self-Sufficiency & Solar Energy

Carrying forward the Nearings' philosophy of self-sufficiency, the board of stewards discussed for several years how to replace the grid-supplied electricity at the Center with renewable energy. The stewards planned on a solar-electric (photovoltaic; PV) system large enough to power the home with the few appliances the Nearings used—a refrigerator, chest freezer, water heater, and clothes washer. But the projected cost—about US\$20,000—was too high for the Center, which operates entirely on donations from visitors and the community.

Enter local renewable energy enthusiast Kimball Petty, who lives a dozen miles from the GLC. He added solar and wind energy systems to his home and workshop in 1995. Kimball's home is a repeat feature on the annual solar homes tour sponsored by the Northeast Sustainable Energy Association. Through Kimball's efforts, the Richard S. Petty Charitable Foundation provided a US\$5,000 grant to install a solar-electric system at the GLC.

With these funds available, a smaller, expandable system—at a cost of US\$8,000—was proposed. The remaining US\$3,000 was met by contributions from visitors, the local community, and the scattered community of people who continue to support the Nearings' pioneering work.

Energy Conscious Residents

Travis Klami and Rebecca Hein were resident stewards at the time of the installation, and were instrumental in getting the solar project underway. They had experienced living without electricity before moving to the GLC. "The Nearings didn't have electricity at all when they lived on their first homestead in Vermont," says Rebecca.

"When we moved to the Good Life Center," says Travis, "we committed to not using the big appliances. We washed clothes by hand most often, then occasionally threw everything in the washer. The water heater was disconnected, though, so we didn't use energy heating water."

Instead of using a refrigerator, they stored harvested potatoes, carrots, beets, cabbage, and much more in the root cellar. Canning jars held tomato sauce, applesauce, and blueberries. Sauerkraut and pickles fermented in crocks. In warmer months, they cooked on a rocket stove—a small, efficient stove that produces a very hot flame with only a handful of



Travis Klami, Daryl DeJoy, Stu Hall, and Rebecca Hein enjoy a moment in the sun with the newly installed solar-electric system.

Daryl DeJoy (left) wires the battery bank while Stu Hall runs cable to the system's inverter.



small sticks. For slow cooking, they moved the boiling pot of food to a "haybox cooker"—a well-insulated box where food can continue to cook for hours without additional heat input. In the winter, the old iron cookstove was a welcome companion in the kitchen.

Travis and Rebecca chose not to have a car. Instead, they relied solely on their bicycles for transportation. During the winter months, they rigged their bikes with studded tires, making year-round, pedal-powered transportation over New England's roads possible.

Experienced Friend

Rebecca and Travis were old hands at living *without* electricity, but did not have experience with solar electricity. For advice, they turned to their neighbor and friend Dennis Carter, who uses a single 80-watt PV panel to power a handful of small electrical loads at his off-grid home on Deer Isle. Dennis explained solar-electric systems to Rebecca and Travis, and helped them estimate the draw of the electrical loads they actually used on the homestead (see "Good Life Center Loads" table).

"Most people are surprised to find out that we actually use more electricity in the summer," says Travis. "The water pump uses a lot during dry years when the garden needs supplemental watering." The two main energy-saving changes to accommodate the solar-electric system were replacing incandescent lightbulbs with compact fluorescent ones and installing an efficient, no-surge well pump manufactured by Grundfos.

System Installation

Local solar-electric contractor Daryl DeJoy, owner of Penobscot Solar Design, designed the 690-watt system. "My mother was good friends with Helen, and I met her several times before she passed away. I really feel she would have gone solar if she could have. Both she and Scott believed in living independently," says Daryl.

Good Life Center Loads

AC Loads	Watts	Hours/ Day	WH/Day
Water pump	516	1.00	516.0
Phone	8	24.00	192.0
Video player for meetings	150	0.50	75.0
Laptop computer	45	1.50	67.5
Radio	40	1.50	60.0
Light, living room	46	1.00	46.0
Light, kitchen	45	1.00	45.0
Guitar amplifier	100	0.25	25.0
Light, bedroom	30	0.50	15.0
Total Daily WH			1,041.5

Daryl held an electronic technician's license before working with solar-electric systems, and started installing solar-electric systems in 1988. Daryl is now studying for the North American Board of Certified Energy Practitioners' (NABCEP) certification. One of Daryl's satisfied repeat customers is none other than Kimball Petty, who procured the grant for the GLC system.

Stu Hall, a senior employee of Penobscot Solar Design, acted as the chief installer for this system. He was motivated by the Nearings' conservationist lifestyle. "The population of the United States is way off base in energy consumption," says Stu. "We need to become aware of how much energy we use." Daryl says he is reluctant to design systems for people who are not interested in energy conservation, because he believes reducing overall consumption should be the first step toward living with renewable energy.

Daryl and Stu each donated their labor for the installation, about 20 hours each. Daryl also donated several hundred dollars' worth of miscellaneous hardware.

System Parts & Pieces

"This is a typical small system for a very energy efficient home," says Daryl. He chose Evergreen 115-watt solar-electric panels, an OutBack MX60 charge controller, a Xantrex SW Plus 2524 inverter, and a TriMetric battery monitor. These components work well, and distribution and service for these products are well established.

After surveying the site's solar access, Daryl determined that the best sun exposure was on the home's balcony. Travis and Rebecca approved, since the proposed array location was high profile and would showcase the panels. After Dennis worked on bolstering the balcony's framework a bit to support the increased load, Daryl mounted the PV panels on an adjustable Direct Power & Water rack at a 60-degree angle. "Seasonally, we can adjust the angle of the panels very easily by loosening the bolts just enough to provide a little friction."

Daryl divided the PV panels into two sets of three panels each, wired in series to operate at 36 volts. The charge controller converts the array voltage to 24 volts at the

batteries. The inverter switches to utility electricity to charge the batteries when the batteries are discharged to about 40 percent of full charge. But Travis and Rebecca have never discharged the batteries below 60 percent.

Even though Travis and Rebecca tended toward energy austerity, usually using only about half of the system's actual production capacity, the system is large enough to accommodate future residents, who may choose to use some of the Nearings' appliances. With conscientious energy

Tech Specs

System Overview

Type: Battery-based PV with grid backup

Location: Harborside, Maine

Solar resource: 4.4 average daily peak sun hours

Production: 2 AC KWH per day (estimated)

Utility electricity offset: 80–90 percent

Photovoltaics

Modules: Six Evergreen Solar EC-115 panels, 115 W STC, 16.5 Vmp, configured for 12 VDC nominal

Array: Two, three-module series strings, 690 W STC, 49.5 Vmp, 36 VDC nominal

Array combiner box: OutBack PSPV, with two 15 A breakers

Array disconnect: Xantrex, 60 A, DC-rated breaker

Array installation: Direct Power & Water mount installed on south-facing railing, adjustable tilt

Energy Storage

Batteries: Twelve Exide ESL-500, 2 VDC nominal, 500 AH at 20-hour rate, flooded lead-acid, tubular plate

Battery bank: 24 VDC nominal, 500 AH total

Battery/inverter disconnect: 250 A, DC-rated breaker

Balance of System

Charge controller: OutBack MX60, MPPT, 36 VDC nominal input voltage, 24 VDC nominal output voltage

Inverter: Xantrex SW Plus 2524, 2,500 W, 24 VDC nominal input, 120 VAC output

System performance metering: TriMetric TM-2020 AH meter

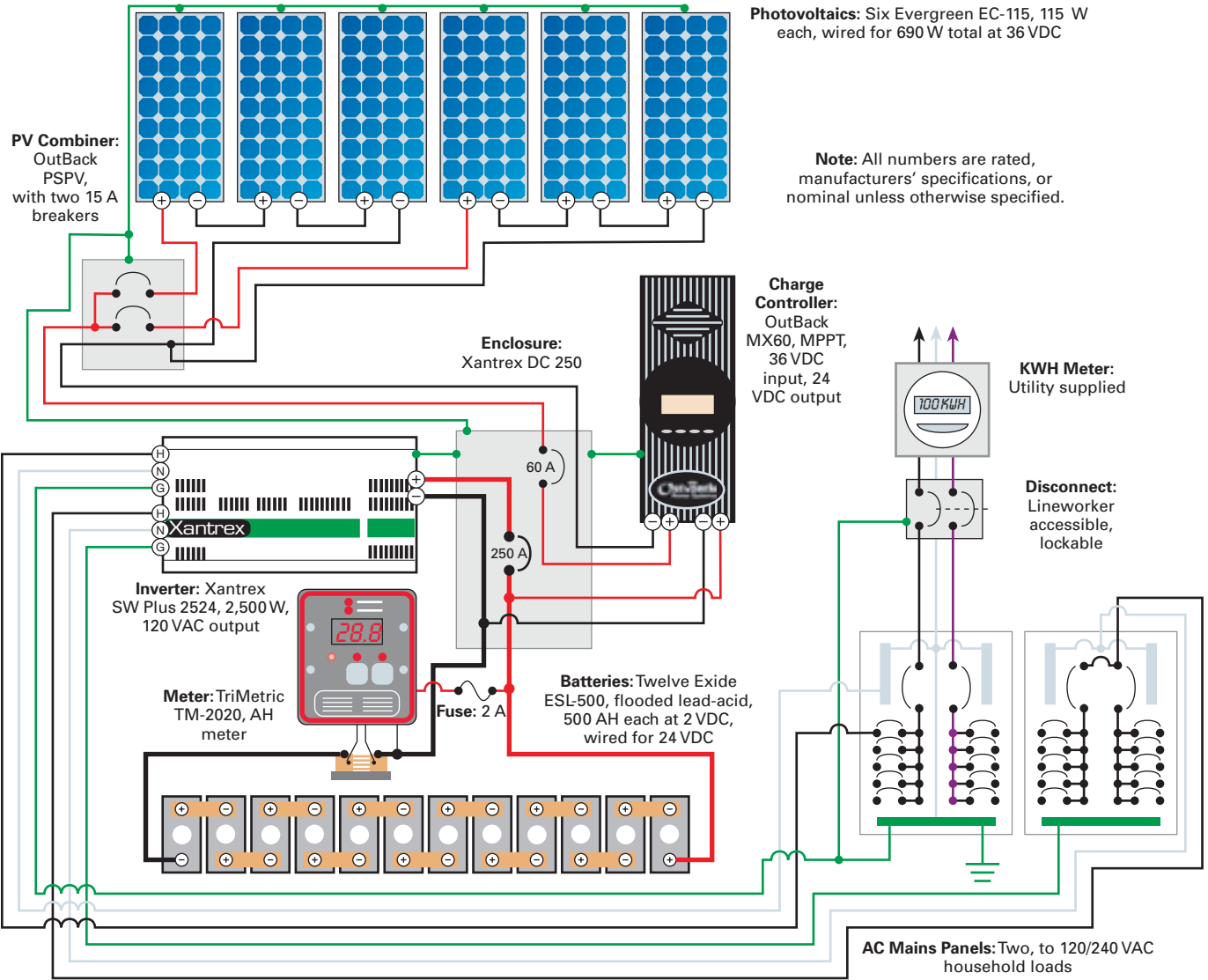

The balance of system components are housed in the GLC's cellar.

practices, Daryl estimates that the system will supply 80 to 90 percent of the electricity required for the GLC. As an educational nonprofit, the Center also experiences occasional periods of high energy use, which the grid-tied system can meet. A school group staying for a weekend could quickly drain a similarly sized stand-alone system. Eventually, GLC stewards hope to raise funds to install energy efficient appliances and to sever ties to the utility.

Lighting the Way

Travis and Rebecca worked hard at the GLC to spread the Nearings' social and simple living practices. "I really love presenting this option to





Daryl programs the OutBack charge controller.

teenagers and younger kids—that school, college, and jobs aren't the only path," says Rebecca. "This could be their life."

"The idea that people don't need a conventional job is new to many people," says Travis, who enjoys sharing Scott Nearing's more radical ideas with people who come to visit.

"In many ways, the homestead stays itself, but in other ways it reflects the personalities of the resident stewards," says Travis. "New ideas keep the place fresh." Monday night meetings were established by Scott and Helen Nearing to discuss social and political issues, consumerism, and personal responsibility. "Everything from compost to communism was discussed weekly," wrote Helen in *Continuing the Good Life*. Now, future Monday night meetings will continue to spread the good life message under lights powered by solar electricity produced right on the homestead.

Good Life System Costs

Item	Cost (US\$)	% of Total
6 Evergreen Solar EC-115 PV panels	\$3,570	41.4%
Xantrex SW Plus 2524 inverter	2,095	24.3%
12 Exide ESL-500 tubular plate batteries	800	9.3%
DP&W adjustable PV mount	675	7.8%
OutBack Power MX60 MPPT charge controller	645	7.5%
Xantrex DC disconnect, 250 A with 60 A array breaker	380	4.4%
OutBack Power combiner box with 15 A breakers	160	1.9%
11 Battery cables, 2/0	154	1.8%
Zephyr Power Vent, 24 V	79	0.9%
2 Inverter cables, 4/0	75	0.9%

Total \$8,633

Access

Dave Evans, 605 Naskeag Rd., Brooklin, ME 04616 • 207-359-2032 • devans@hypernet.com

Bogart Engineering, 19020 Two Bar Rd., Boulder Creek, CA 95006 • 831-339-0616 • Fax: 831-338-2337 • bogart@bogartengineering.com • www.bogartengineering.com • TriMetric battery monitor

Direct Power & Water, 4000 Vassar Dr. NE, Albuquerque, NM 87107 • 800-260-3792 or 505-889-3585 • Fax: 505-889-3548 • info@directpower.com • www.directpower.com • PV rack

Evergreen Solar Inc., 259 Cedar Hill St., Marlboro, MA 01752 • 508-357-2221 • Fax: 508-357-2279 • info@evergreensolar.com • www.evergreensolar.com • PV panels

Exide Technologies, 13000 Deer Trail Pkwy., Bldg. 200, Alpharetta, GA 30004 • 800-523-4622 • Fax: 678-566-9188 • www.exide.com • Batteries

Good Life Center, 372 Harborside Rd., Harborside, ME 04642 • 207-362-8211 • information@goodlife.org • www.goodlife.org

Grundfos Pumps Corp., 17100 W. 118th Terrace, Olathe, KS 66061 • 913-227-3400 • Fax: 913-227-3500 • www.grundfos.com • Well pump

OutBack Power Systems, 19009 62nd Ave. NE, Arlington, WA 98223 • 360-435-6030 • Fax: 360-435-6019 • sales@outbackpower.com • www.outbackpower.com • Charge controller

Penobscot Solar Design, 569 Back Ridge Rd., Penobscot, ME 04476 • 207-326-0779 • info@penobscotsolar.com • www.penobscotsolar.com

Richard S. Petty Charitable Foundation • Kimball Petty, PO Box 67, Little Deer Isle, ME 04650 • Note: No new grants will be made through 2010

Xantrex Technology Inc., 5916 195th St. NE, Arlington, WA 98222 • 800-670-0707 or 360-435-8826 • Fax: 360-435-3547 • info@xantrex.com • www.xantrex.com • Inverter

Zephyr Industries Inc., PO Box 52, Salida, CO 81201 • 719-530-0718 • Fax: 719-539-7052 • mail@zephyrvent.com • www.zephyrvent.com • Battery box ventilator



The TriMetric

Model 2020

BATTERY SYSTEM MONITOR



Displays vital battery system data to help users provide better battery care, increase conservation awareness and aid system maintenance.

- Volts • Amps • Amp-hours • Min/Max volts
- Days since charged • Battery % full
- Remote locatable • More !

Bogart Engineering • (831) 338-0616
www.bogartengineering.com
 19020 Two Bar Rd. Boulder Creek, CA 95006 USA

The PentaMetric

NEW BATTERY SYSTEM MONITOR: AVAILABLE NOW



When you need A LOT MORE than a TriMetric

- 3 amp/amp-hour channels/2 volts channels: monitor 2 battery systems and/or solar & wind inputs • 26 different (Battery DC) data • Complete control from remote display unit and/or from "Windows" computer • Output control for generator start or battery alarms • Audible/visual alarms for low/high battery • Customize display to show only data you want • Print your own label to identify switches • Data logging identifies system problems

Price: (Suggested retail) about \$320 (with computer interface only), \$419 (with front panel display only) \$519 for both. Our beta testers found very few problems, which we've listed on the web site. We've incorporated changes to correct bugs, and also added a few additional functions. If you own one of the beta test models we will upgrade your meters—you just have to ask. For the most recent info, please visit our website.

The experts agree... these are the only RE books you need!

"In my 30 years' professional experience in remote wind and solar power, I've seen good books, bad books, and obsolete books so I appreciate these two! They are up-to-date for 2005, and will remain useful for years to come. The author gets his priorities straight, putting high emphasis on conservation and efficiency, which is the key to making renewable energy economical. They are well illustrated and easy to understand. I recommend these books to homeowners, professionals and educators who need a practical introduction and hands-on guidance."

Windy Dankoff

Educator, Founder of Dankoff Solar Products, Inc.

"Bill has a way of making complex technologies interesting and easy to understand. The Renewable Energy Handbook is a must for those people who want to learn more about energy sustainability and off-grid living."

Mike Bergey

President, Bergey WindPower

"Bill Kemp is one of the most exciting, energetic, and authoritative lecturers on renewable energy for homeowners that I've seen - and I've seen a lot of them. The Renewable Energy Handbook captures that enthusiasm. Bill Kemp is one of North America's foremost experts on living with renewable energy beyond the last utility pole. We need more Bill Kemps."

Paul Gipe

Author of Wind Power: Renewable Energy for Home, Farm, and Business



OFF-GRID

Bill Kemp, one of North America's leading authorities on renewable energy, has written the most comprehensive book covering every aspect of sustainable and off-grid living.

or ON-GRID

His second book is a complete guide to using renewable energy to supplement your grid power, heat your water, power your automobile and protect your family from rising and uncertain energy costs and supply.

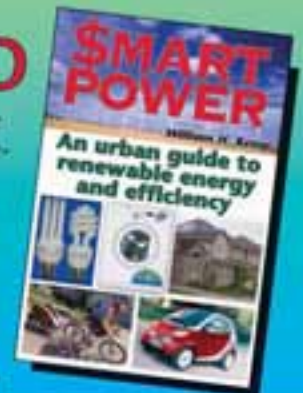

Ask your RE Dealer for these books!
 or available at www.aztext.com and bookstores everywhere.

No Power? No Problem!

There is more to a working renewable energy system than a cheap deal on a pile of hardware.

We Provide:

Complete service. We do solar, wind, microhydro and pumping systems. Load analysis, site survey, system design, sales, installation, user training, and tech support long after the warranties expire. We live on renewable energy, have 20 years of experience, and have established over 500 systems. We specialize in NEC® compliant, safe systems that will make your Electrical Inspector smile!

Equipment for DIY. We offer reasonable deals and technical reality checks. Why settle for a packaged system when you can have yours custom designed by an expert?

Your best resource is a local pro. Tap into our network of qualified, competent Electron Connection associates across the country.

Going into the Biz? Why talk to a "sales technician" when you can talk to an electrician? We KNOW what works and how it works. We offer technical support, system design help, prompt shipment, fair pricing and NO BULL. Local referrals always. Electrical competence required.

Electron Connection

Bob-O Schultze
CA Electrical Lic #613554
OR CCB Lic #149724



800-945-7587

 toll free

www.electronconnection.com

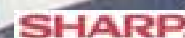
 online catalog

PO Box 203, Hornbrook, CA 96044 USA

Voice / Fax: 530-475-3401 • E-mail: bob-o@electronconnection.com

SEI Hands-On Workshops



Colorado Workshops

PV Design & Installation	July 11 - 22
Women's Photovoltaics	July 11 - 22
Successful Solar Business	July 23 - 24
Advanced Photovoltaics	July 25 - 29
PV Industry Week	Aug 1 - 5
Micro-Hydro Power	Aug 1 - 5
Solar Water Pumping	Aug 6 - 7
Wind Power	Aug 8 - 19
PV Design & Installation	Aug 22 - Sep 2

Workshops Outside of Colorado

Utility Interactive PV, NJ	Sept 12 - 14
Intro to Renewables, WA.....	Oct 8
PV Design & Intallation, WA.....	Oct 10 - 15
RE for the DW, Nicaragua.....	Oct 17 - 23
Micro-Hydro, WA.....	Oct 17 - 21
Wind Power, WA.....	Oct 24 - 29

Solar & Radiant Heating Systems Design Workshops

Washington, DC.....	Oct 13 - 15
Reno, NV	Sept 15 - 17
Eugene, OR.....	Nov 10 - 12

Online Workshops

PV Design.....	Sept 6 - Oct 14
.....	Oct 31 - Dec 9
Solar Home Design....	Sept 6 - Oct 14

Call for Our 2005 Catalog

HANDS-ON EDUCATION FOR A SUSTAINABLE FUTURE



SOLAR ENERGY
INTERNATIONAL

PO Box 715 - Carbondale, CO 81623
tel: 970-963-8855 - fax: 970-963-8866
sei@solarenergy.org

WWW.SOLARENERGY.ORG



A Cleaner Hybrid

Shari Prange

©2005 Shari Prange

Suddenly, hybrid (gas/electric) vehicles are popping up everywhere—in the news and on the roads. The most widely seen and known is probably the Toyota Prius, which led the movement with its introduction in the United States in 2000.

Extra battery capacity that can be charged from the grid or RE is the “+” that makes the Prius+ more than an ordinary hybrid.



Hybrid electric vehicles (HEVs) are seen as being the best of both worlds. They are cleaner and more fuel thrifty than any conventional internal combustion engine (ICE) car, but still have the freedom and security of long range and quick refueling. So what could be better? A plug-in hybrid (PHEV)—the Prius+. Or, as its designers like to call it, a “gas-optional” hybrid (GO-HEV).

What Makes It Better?

All HEVs on the U.S. market today are essentially high-mileage gas cars. All of the energy to recharge the batteries comes from the gas engine. There is no way to plug into the grid—or into a renewable energy (RE) system. They have been designed this way, with a tiny battery pack that can only run for a few minutes before it needs to be topped off by the ICE.

The HEV gets its “green” credibility in four ways. First, it combines an ICE with an electric motor in a carefully synchronized fashion to take advantage of the most efficient operating modes of both, with one’s strengths compensating for the other’s weaknesses, and vice versa. Second, it stores some energy that is generated by braking, rather than wasting it as heat. Third, it shuts off the ICE completely when it is not needed, such as while

coasting, braking, or idling. Fourth, some HEVs, such as the Prius, also shut off the ICE for low-speed driving, and run purely on battery power.

The Prius+ continues to take advantage of all of those strategies, and adds a fifth. By increasing the capacity of the battery pack and adding the ability for plug-in recharging, the Prius+ shifts the emphasis toward the electric drive and away from the ICE system.

Electricity available from plug-in recharging means less gas is needed. With the Prius+, you might do your normal in-town errands primarily using electricity, and come home to recharge from the grid or your home RE system, after using only a few drops of gas. Then, when you need to travel at highway speeds or for long distances, the ICE system comes into the picture more fully.

Birth of a Notion

The Prius+ is a project of CalCars, a California nonprofit organization, and is the brainchild of Felix Kramer, who started to get excited about clean innovations in cars in 2001. Long-time EV engineer Ron Gremban noticed the project and came on board in 2004.

The driving concept, so to speak, behind CalCars is the idea that the current automotive market model needs to be turned upside down. Instead of manufacturers and the government telling people, "Here are the cars you can have," the CalCars plan is for the people to describe the car they want and tell the manufacturers, "Build it, and we'll buy it." CalCars intends to be the catalyst to make it happen.

By 2002, CalCars was focusing on the PHEV design. Other ideas, such as hydrogen cars, were found to be still too futuristic for the general public, and the technology had too many question marks. The PHEV took familiar existing cars and stretched them into new territory. The Prius was the perfect platform for the CalCars project, since unlike the Insight and some other hybrids, the Prius has an all-electric, low-speed mode.

Baby Steps

The first step was to build a prototype and proof the concept. For the first car, the entire stock 2004 Prius system was left intact and unchanged, and a second operating mode was added on. The same vehicle could be driven in either HEV or PHEV modes for comparison testing.

The factory battery pack had nickel-metal-hydride batteries at 201.6 V and 6.5 AH (1.3 KWH), and weighed 99 pounds (45 kg). A replacement pack was added in the empty well below the hatchback deck, and the factory pack, while still in place, was disconnected for most testing.

For the initial testing, a lead-acid pack of electric bicycle batteries at 216 V and 12 AH (2.6 KWH) was used, weighing 240 pounds (110 kg). In addition, a custom battery management and controller/display unit, designed by Energy Control Systems Engineering (EnergyCS) of Monrovia, California, was installed. This replacement battery pack was charged by a Brusa NLG5 charger from a standard 120 VAC outlet in three hours.



CalCars principals Felix Kramer and Ron Gremban.

With these vehicles, we can no longer talk about "gas mileage," because the car is running on a combination of gasoline and electricity. The combination of these two represents your true energy consumption. Gas usage is decreased because the car is substituting electricity from the grid or RE system for part of the motive power. The car is using the same amount of energy, but some of it is now coming from a source other than gasoline.

Once the grid-supplied charge in the batteries is depleted, the car will draw all of its energy from gas, just like a factory hybrid. But a very large percentage of daily driving can be done in PHEV mode, combining electricity with gas power.

A second prototype has been built by EnergyCS, using lithium-ion batteries to achieve a range of 30 miles (48 km) on batteries alone or 60 miles (97 km) with an ICE assist before reverting to HEV mode. The original Prius+ is being updated to use nickel-metal-hydride batteries for an expected range of 20 miles (32 km) electric and 40 miles (64 km) assisted. With these ranges, the PHEV mode could handle the majority of many people's daily driving needs.

Eventually, through the test results of the various prototypes, one or more optimized designs will emerge. In production conversion kits, the PHEV function would be fully and seamlessly integrated into the factory HEV system.

How Does It Work?

The factory HEV Prius uses a small battery pack that is not designed for very deep discharge. It's just enough to

Who's Got the Button?

This is the hot question among American Toyota Prius owners. On the dash of their cars, there is an intriguing button-shaped blank. Upon investigation, it turns out that in Japanese and European versions of the Prius, an EV-mode button comes standard from the factory. It's not available on U.S. cars, though no one knows for sure exactly why. Speculations range from EPA red tape to dark conspiracies.

Here's what the button does. When you start a parked Prius, the ICE will automatically turn on and run for a short time to warm the engine and the catalytic converter. This is the dirtiest part of the ICE cycle. By engaging the button first, you skip this warm-up run. This allows you to move up to an estimated 2 miles at low speeds without using the ICE. If you accelerate briskly, or exceed 35 mph (55 kph), or if your batteries' state of charge is too low, the ICE will override the button and turn on.

How useful is it? It would be useful if you're only moving a short distance and then will park again, or if you want to move silently. However, in some situations it could actually make your fuel economy worse, and there is the potential of shortening your batteries' life. Its value is probably exaggerated simply because it is mysteriously forbidden to Americans.

The factory Toyota parts can be found readily on eBay, and other simple switches can be substituted. Detailed installation instructions are also available on the Internet.

55 kph), and do it using almost no gas at all if you come home to plug into the grid. Of course, any time you're driving in pure electric mode also means no emissions. "Fuel" cost in pure electric mode is about US\$0.03 per mile if you charge from the grid. If you use excess RE, the cost is zero.

At higher speeds, the ICE is needed to provide extra power, but even then, the electric system will carry a bigger part of the load than in the factory Prius. To put it another way, the ICE will still be used, but gas usage will be lower with the Prius+ PHEV than with the factory Prius HEV. In the worst case, if you drive far enough to reduce the batteries to their "empty, need charging" level, the car simply reverts to original HEV mode, and you continue to drive with the ICE providing the motive power, assisted as usual by the motor/generator.

Real-Life Example

Let's look at a real life driving example to understand this better. Ron Gremban lives in a hilly area north of San Francisco and drives the first Prius+ prototype with the lead-acid battery pack. He can drive it as a plain factory HEV Prius in pure electric mode at low speeds on flat ground for about 2 miles (3.2 km) maximum before the ICE kicks in to charge the batteries. In the lead-acid Prius+, he can drive in the same pure electric mode for about 10 miles (16 km).

Most real-life driving, however, includes brisk acceleration, hills, or speeds higher than 35 mph (55 kph), so it requires the mixed gas/electric mode. The grid-charged

Dominic Crea dreams of plugging in his Prius.



power the car at low speeds for a mile or so. Then the ICE automatically kicks in to handle sustained propulsion, and to recharge the battery as well. In normal driving, the ICE provides the main motive power, often assisted by the electric motor, but is often stopped completely when the vehicle is stopped, traveling slowly, or decelerating, as the hybrid controller deems most efficient.

The Prius+ will have either a secondary battery pack, or a single replacement pack. This issue is still to be determined depending on CalCars' results with different prototype systems. Either way, the new batteries will have greater capacity as well as the ability to handle deeper discharges. Turning the ICE on and off will still be handled by Toyota's hybrid controller, so it will all be automatic.

For the driver, this means that the Prius+ can drive farther in pure electric mode at low speeds (under 35 mph;

Plug-In Hybrid: Closer Than You Think

Dominic Crea

©2005 Dominic Crea

Fuel cell vehicles (FCVs) and the “hydrogen economy” have commanded much attention in the press over the years. The technology has often been referred to as “revolutionary,” though I would apply the term “hyped” more readily. Meanwhile, a variation of an existing and well-established technology—the hybrid electric vehicle (HEV)—is undergoing a quiet evolutionary change that promises to take the world by surprise.

As the natural next step in automotive design, the plug-in hybrid (PHEV) retains the essential characteristics of a conventional hybrid with some important differences. Both the battery bank and electric motor can be beefed up, while the internal combustion engine (ICE) can be reduced in size. The increased battery bank allows the PHEV to travel up to 60 miles on a charge, while the downsized engine (now operating very close to its maximum efficiency) raises the fuel economy to 80 mpg (2.94 l/100 km) and beyond.

Incidentally, neither of these changes is technologically daunting. NiMH batteries have proven themselves more than equal to the task (the RAV4 Electric achieved 120 miles; 193 km per charge) and large, electric-drive motors are now commonplace (the Ford Escape hybrid boasts an 87 hp electric motor).

The Benefits

On average, 70 percent of all cars on the road drive less than 40 miles each day. A PHEV operating in “electric mode” and being charged from renewable sources of electricity could easily achieve this range. Such a vehicle has the potential for saving more than 75 percent of the fossil fuel we now use for domestic transportation. But there’s more.

Unlike an FCV, which requires a source of hydrogen, the PHEV can literally be plugged into any 120-volt outlet. It can be “fueled” at home or work using the standard electric grid and, in striking contrast to the FCV, is not plagued by limited driving range or fuel infrastructure.

With the ability to be charged via photovoltaics and wind, most (if not all) of the “fuel” could be derived renewably. Indeed, with the very real possibility of manufacturing homegrown biofuels—ethanol and biodiesel for example—the opportunity for storing significant amounts of fuel for longer trips becomes eminently practical. On the other hand, an FCV system is pretty much out of the running. At half the energy efficiency (see *HP101*, “The Hydrogen Debate”), it would require at least twice the number of solar-electric

panels as would the PHEV, along with a complete and very expensive system with electrolyzer, pump, compressor, and tank.

A PHEV is the perfect technology for using off-peak electricity. In fact, it complements the existing electric grid infrastructure to a degree only dreamed of in the FCV. With the ability to make use of, as well as generate, excess electricity, PHEVs present utilities with an incredible buffering potential. In contrast, each FCV would need an onboard electrolyzer, compressor, and provisions for capturing exhaust water if it is to be re-electrolyzed to offer the same benefit.

The PHEV’s power train is redundant. If the electric drive system fails, the vehicle will continue operating on the engine alone—a comforting thought when stranded on a lonely road, far from home. The same is not true of an FCV, hybridized or not. When its electric motor dies, you’re stuck until the tow truck arrives.

Finally, a PHEV is not speculative technology. All of its components are well known in terms of their expense, reliability, and practicality—and the changes necessary are relatively minor. The same cannot be said of FCVs. With many problems yet to be solved including cost, reliability, cold-weather performance, fuel availability, and infrastructure, an FCV has a very long way to go before it becomes a practical reality.

And If You Order Now...

A PHEV just naturally comes equipped with one very big electric generator, ready to serve as a useful recreational, utility, or backup electricity source (30 KW or more). As mobile as the car itself, immune to weather, and virtually theft-proof, it would be rugged, reliable (most generators fail when needed most because they remain inactive for extended periods of time), extremely long-lived, incredibly efficient, low pollution, and as quiet as a small air conditioner—all of this a consequence of the hybrid design.

As a backup electricity source, a PHEV could operate on batteries alone, with absolute silence, to power an entire house for a limited time in an emergency before the engine would automatically come on for a few hours of very quiet recharging. Quite simply put, it would be the most ideal generator one could hope for, and all of this as a benefit of owning a PHEV.

Are PHEVs in our future? Most probably yes! In the meantime, keep your solar-electric panels pointed south—you may be charging that PHEV on solar electricity sooner than you think.

battery capacity of the PHEV provides extra motive power in this mixed mode for about 20 miles. By that time, you've used up your grid charge, and the car becomes a plain HEV again, with the gas engine providing all of the charge to the batteries.

So let's say Ron leaves home with a full gas tank and all his batteries fully charged, and drives for 20 miles in PHEV mode, using both systems together. At the end of the 20 miles, he refills his gas tank and recharges the batteries. He will add about one quart of gas to the tank, and about 2.6 KWH of electricity to the batteries. In a factory HEV Prius, he would need to add a little less than half a gallon (2 l) of gas, and no electricity.

The second prototype with the lithium-ion batteries has exhibited better performance in flatter southern California driving conditions, and has a lot longer PHEV range. It can go for 30 miles in low-speed, pure-electric mode as a PHEV, or 60 miles in mixed gas/electric high-speed mode before reverting to factory HEV performance. This lithium Prius+ has been driven for 60 miles on 1/2 gallon of gas plus 7.5 KWH of charge vs. over a full gallon of gas as a factory HEV at 55 mpg (4.28 l/100 km).

Where Does It Go from Here?

So how does the Prius+ make the jump from prototype to production? CalCars (a nonprofit) is pursuing multiple paths on this. One path would be installed kits provided by for-profit companies working in partnership with CalCars. In this scenario, Prius owners take their cars to franchised installers for conversion to PHEV.

Although it's too early to quote prices, the initial kits would have significant costs, perhaps in the low five figures. Buyers would have to be true believers with a generous budget, but enough of them (celebrities and upper income buyers with environmental or technology interests) could both popularize the car and bring the pricing down.

This brings up another reason the Prius system—specifically the second generation Prius—was chosen for the platform in the first place. With the second generation of the Prius, Toyota removed its own name from the proprietary drive system, changing it from the "Toyota Hybrid System" (THS) to the "Hybrid Synergy Drive" (HSD). The reason for this change was to allow Toyota to license the technology for use by other manufacturers, such as Nissan.

CalCars believes that, once developed, the conversion components will work with any car using the Toyota technology. Some cars, with more space for batteries, could get even better performance. This greatly expands the number and models of cars suitable for PHEV conversion, which could aid in increasing the numbers of conversions and reducing costs.

Another issue here is warranty. While the conversion components and their installation would carry a full warranty from the installer, the installation might void part or all of the original factory warranty. It will depend on how willing the original manufacturer is to support the concept. So potential buyers may need to be willing to accept the risk.

This brings up another path to production. This involves collecting a group of buyers (a "buyers club") and presenting a bulk order to an auto manufacturer, such as Toyota. CalCars is working with other PHEV advocates to recruit fleet customers to get the numbers to make this effective, but private parties could join the list as well. Government tax credits and corporate- or foundation-sponsored support could reduce the price of the first cars to buyers. With enough pre-committed buyers, CalCars hopes that Toyota or another manufacturer could be persuaded to produce the cars.

Where Will It End Up?

Felix Kramer hopes that the PHEV concept will continue to grow and evolve. For example, the IC component could become a biofuel instead of petroleum fuel. And, as performance improves and people become more familiar with the cars, they will realize that the vast majority of their driving, particularly for a family's second car, doesn't require the ICE system at all. The PHEV could actually be the bridge back to full battery-electric cars.

Access

Shari Prange, Electro Automotive, PO Box 1113-HP, Felton, CA 95018 • 831-429-1989 • Fax: 831-429-1907 • electro@cruzio.com • www.electroauto.com

Dominic Crea, Science Wonders, 37880 Moravian, Clinton Township, MI 48036 • dom120@juno.com

CalCars, PO Box 61045, Palo Alto, CA 94306 • 650-520-5555 • info@calcars.org • www.calcars.org

EnergyCS, 715 South Myrtle Ave., Monrovia, CA 91016 • info@energycs.com

See reviews of the Toyota Prius in *HP83* & *HP102*



BZ Products Model MPPT500

500 watt 45 amp Maximum Power Point Solar Control

- Boost charge current up to 30%
- Up to 45 amp output current
- Microprocessor control
- 95 % efficacy
- 500 watt PV input
- Universal PV input 12 to 48 volts
- 12, 24 or 48 volt output
- Digital metering
- PWM float control
- Battery temperature sensor standard
- Five year warranty
- Made in U.S.A.



BZ Products, Inc.
314-644-2490 • www.bzproducts.net • bzp@bzproducts.net
7614 Marion Ct., St. Louis, MO 63143, USA

As RELIABLE As THE SUNRISE

At **APOLLO SOLAR**, WE'VE BEEN DESIGNING INDUSTRIAL STRENGTH PRODUCTS FOR YEARS.

MPPT
CHARGE CONTROLLERS,
GRID-TIE INVERTERS,
BACK-UP POWER SYSTEMS,
ENERGY METERS

SO WHEN IT CAME TIME TO BUILD OUR **CHARGE CONTROLLERS** AND **INVERTERS** FOR THE RESIDENTIAL AND COMMERCIAL **PV** MARKETS, WE USED THAT EXPERIENCE TO CREATE THE MOST RELIABLE PRODUCTS AVAILABLE.

THE RESULT: STATE-OF-THE-ART SYSTEMS WITH THE LONGEST STANDARD WARRANTY ON THE MARKET – **10 YEARS.**

VISIT US ON OUR WEBSITE AND SEE THE DIFFERENCE.....

www.apollo-solar.net



APOLLO SOLAR

23 Francis J. Clarke Circle, Bethel,
CT USA 06801. Tel.: +1 (203) 790-6400

Photograph courtesy of NASA



SOLAR CONVERTERS INC.

We design and manufacture Power Control Solutions for your Renewable Energy Systems!



Linear Current Boosters

Increases Solar Pump Performance

- 12 / 24 V @ 7 amps
- MPPT
- Voltage Limited
- Fused Output



DC Autotransformers

Bi-Directional DC-DC Converter

- Battery Balancer / Equalizer
- Converts Battery Power to Different Voltages
- Up / Down Converter



Battery Desulphators

Extends Battery Life

- Recovers Sulphated Batteries
- Single unit 12 to 48 V
- Adjustable Pulse Strength



Linear Voltage Boosters

Keeps a Constant Battery Voltage to your Equipment

- Charge a Battery from a Lower Voltage Battery or PV
- Water Pump Booster and Controller



Generator Starters

Starts / Stops Generators based on Battery Charge

- Single unit 12 to 48 V
- Controls any Generator
- Temp. Compensated

ALSO...

- MPPT Power Tracker™ Charge Controllers
- Cathodic Protection Controllers
- Voltage Controlled Switches
- Solar Lighting Controllers

Please visit www.solarconverters.com for MORE products and details

C1-199 Victoria Road S., Guelph, ON, N1E 6T9, Canada Phone: 519-824-5272 Fax: 519-823-0325 E-mail: info@solarconverters.com



Bill Kelsey

©2005 Bill Kelsey

Hydro New England Style

Lights make the spirit happy, especially here in New England, but I did not want to put up with the noise of a generator. I had been living off grid using propane lights, which can be a fire hazard and are too hot in the summer. After talking with Gordon Ridgeway, a friend living off grid on solar electricity, I began investigating alternatives. My property is heavily wooded, so I only get a few hours of sunshine on an average summer day, and even less in the winter. What I do have is a brook with a good downhill run. It drains about 2,000 acres, all in a state park with no houses.

My 10-acre woodlot in Sharon, Connecticut, was once used by early settlers to grow fuelwood for their homes. Because of right-of-way restrictions, there is no access to the utility grid. With only a 30-foot (9 m) drop and the cold New England climate to work with, I have constructed an innovative, hydroelectric system that sustains me completely off grid.

Starting from Scratch

When I started twenty years ago, I had never seen another hydroelectric system. I built mine completely by trial and error. I ordered a Harris Hydro turbine from a retailer for 15 feet (4.6 m) of vertical drop. My first Rube Goldberg setup was a 275-gallon (1,040 l) flat tank with the side cut out of it, so that water coming off the top of my rock and timber dam passed through a homemade filter and into two, 2-inch pipelines laid side by side in the brook.

After many months building it, and lots of friends' ideas, it was disappointing when the turbine only produced 30 watts at best. I tried to get a refund, but the supplier refused, so I was stuck with all my toys and no electricity. Out of desperation, I called Don Harris—and thank goodness



**The four-nozzle
Harris turbine
generates
3.6 KWH per day.**

I did! Don helped me save face. You see, I had become the laughingstock of the town. I love tinkering, so after Don explained the requirements of a successful hydroelectric system, I knew my brook could produce a substantial amount of electricity with the right setup.

Don started by telling me I had too much pipe friction, so I changed over to 3-inch pipe. It worked a little better, but then I had problems with freezing in winter. Again, Don saved the day. He said I should measure the head (vertical drop) of the brook over the whole course on my property. That came to 30 feet (9 m), twice the head of my original system!

As luck would have it, my friend Bob was selling his 20-ton excavator for US\$15,000, so I mortgaged my house to buy it. Next, I selectively cut oak trees on my property for cash to finance my project. We had a dry summer in '99, so I hired a friend to run the excavator and we dug a pond and a trench running along the brook for 275 feet (84 m). I worked feverishly for three months burying 4-inch PVC pipe, 15 feet (4.6 m) below the surface so it wouldn't freeze in winter. My welding skills came in handy when I fabricated the pipeline's intake, and I then built a concrete pad for the hydro turbine, complete with a 1/8-inch (3 mm) plate steel, bombproof cover.

In August, we sometimes have heavy rains. That August, we had 7 inches (18 cm) in 24 hours! I was scared to death, but my new earthen dam held, and I was off making 100 watts—not much, but you learn what you can live with.

One drawback in the early system was that Don's alternators loved to eat up brushes. I had a spare alternator around at all times so I could switch them out and replace the brushes, but it's a big job to change them. Thankfully, Don came out with the brushless, permanent magnet alternator, which I've upgraded to. Now my hydro setup

The intake pipe is secured to the bottom half of a new septic tank hidden beneath the dock.



The removable intake screens are easy to clean.

runs day in and day out, making a continual 150 watts. That's 3.6 KWH per day, which I store in eight, 6-volt golf cart batteries.

Steve Schulze of New England Solar Electric and Larry Riley, my electrician, helped me design my electric panel. This panel includes inverters that convert the DC energy stored in the batteries to AC electricity I can use to power standard, 120 VAC household appliances. It also has a remote start switch for a backup generator, which is located quite a ways from the house, since it creates a racket when it's running. A light at the house tells me if the generator is on. The Onan 5 KW propane generator is used a little bit in the summertime when the stream's flow is low, but

not much in winter—maybe 75 hours total per year. I use it primarily to power big electrical loads for my shop, which includes a welder and an air compressor.

The AC distribution panel feeds 120 VAC circuits, powered by the Trace DR2424 modified square wave inverter. I have a spare inverter just in case I have problems. A DC panel energizes DC compact fluorescent lights in each room of the house.

My system is all up to code. We have severe storms in New England, so even with the best engineering, the possibility of a direct lightning hit is still a threat. We have done a lot to protect from lightning, but there are no easy answers.

Using the Energy

With a frequent surplus of electricity, I decided to see how else I could use it. I had heard how great radiant floor

Kelsey System Energy Flow

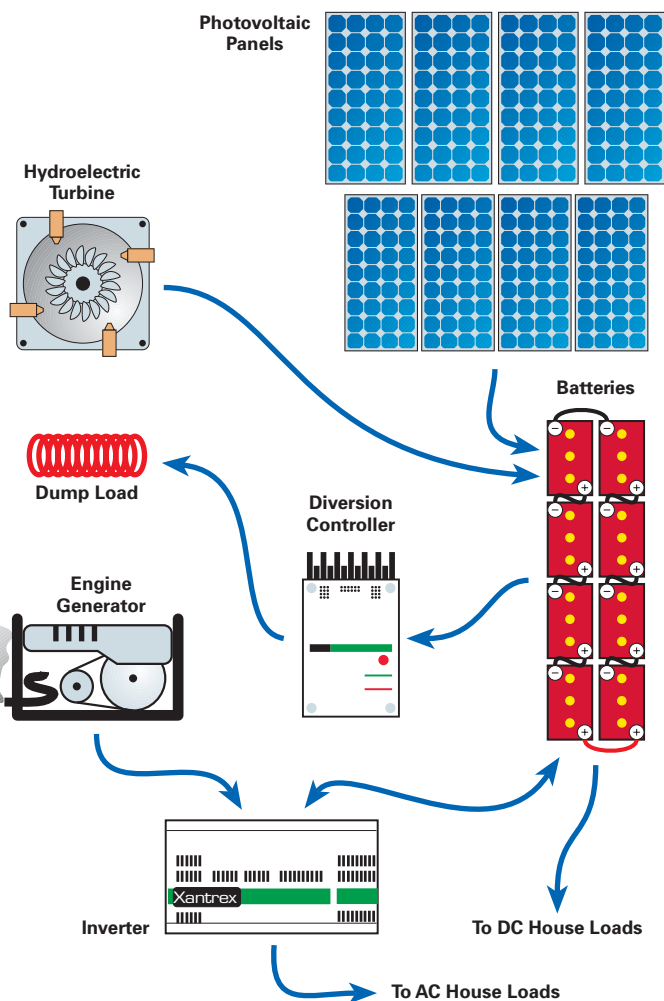

Note: Overcurrent protection and disconnects not shown.



In the power room, hydro and solar power converge. When the batteries are full, excess hydro or solar electricity is used to heat domestic water.

Independent Life

My son who lives in the city once said to me, “If you hopped, skipped, and jumped all the way to town, you still wouldn’t get back in step with the world.” He and my daughter, who lives a simple life in the country, have been a big part of my inspiration to live up to one of my favorite slogans, “Dare to be different—you might impact the world.” When they were young, we took trips to help people in Haiti, and seeing a poor country had a huge effect on all of us. It made us appreciate what we have here, and urged me on to be more self-reliant and less wasteful.

Bill and Patricia Kelsey in front of their energy supply—the pond.



heating is, but I wanted a DC circulating pump for the most efficient energy usage. As luck would have it, Ivan labs Inc. was just coming out with a 24 VDC circulating pump—the El-Sid. Using my existing Aqua-Therm outdoor wood furnace for heating and the electricity from my hydro to run the pump, my home is peaceful and warm.

One thing for sure, Don Harris has changed my life forever—thanks, Don! Lights do make your life happier, and now I have more than enough electricity to run lights and basic appliances whenever I want. My wife and I lived in a 600-square-foot (56 m²) house for years. When the hydro system finally worked, I decided to double the size of our house, and added four BP 75-watt solar-electric panels and later, four more BP 50-watt panels. The setup complements the hydro turbine, producing at about 420 watts in full sun. I heat my domestic hot water and regulate the output of both my hydro and PV charging systems with a DC water-heating element controlled by a Trace C35 controller.

I had a dream of an independent life, totally off grid, trying something that most people would say, "Oh that's impossible. You can't do that." This is what makes me push on. With direction and encouragement, I was driven to build my dream, one building block at a time.

I am working to get young people to view my home and systems, to let them know it's all right to be different, to follow a different path. Maybe it will make an impact and help make the world a better place to live. I might have given up if hadn't received such great advice from Don Harris, and I'd still be in the dark. Thanks also to *Home Power* for inspiration, to help people like me say, "Yeah! I can do that."

Access

Bill Kelsey, 5 Weber Rd., Sharon, CT 06069 • 860-364-0288

Don Harris, Harris Hydroelectric, 632 Swanton Rd., Davenport, CA 95017 • 831-425-7652

Larry Riley, Riley Electric, 116 Point-of-Rocks Rd., Falls Village, CT 06031 • 860-824-0859 • Electrician

BP Solar, 630 Solarex Ct., Frederick, MD 21703 • 800-521-7652 or 410-981-0240 • Fax: 410-981-0278 • info@bpsolar.com • www.bpsolar.com

New England Solar Electric Inc., 401 Huntington Rd., Worthington, MA 01098 • 800-914-4131 or 413-238-5974 • Fax: 413-238-0203 • nesolar@newenglandsolar.com • www.newenglandsolar.com

Xantrex Technology Inc., 5916 195th St. NE, Arlington, WA 98223 • 800-670-0707 or 360-435-8826 • Fax: 360-435-3547 • info@xantrex.com • www.xantrex.com



Three Men and a Baby!

Introducing the "Water Baby"...
Another breakthrough in water powered generators.



- Brushless permanent magnet design
- Adjustable while running
- Operates with as little as 3 gpm
- 12, 24, 48 volts and higher available



ENERGY SYSTEMS & DESIGN, LTD.
www.microhydropower.com 506-433-3151

User Friendly Hydro Power



Now Featuring Permanent Magnet Alternators

Alternative Power & Machine

4040 Highland Ave. Unit #H • Grants Pass, OR 97526 • 541-476-8916
altpower@grantspass.com

www.apmhydro.com

Harris Hydroelectric

Hydro-Power for Home Use

Introducing a new adjustable Permanent Magnetic Brushless Alternator

- 25 - 30% more efficient than Hi Output Alternator
- Marine Grade Construction throughout
- Re-connectable Stator
- Retrofittable on existing turbine



632 Swanton Road
Davenport, CA 95017
831-425-7652



www.harrishydro.com



America's Largest Business-to-Business Solar Event

Register online at
www.solarpowerconference.com.
When prompted during the
registration process, enter discount
code "HP" to receive a
\$100 discount!

SOLAR POWER 2005

OCTOBER 5-9, 2005

HYATT REGENCY CAPITOL HILL

WASHINGTON, DC

www.SolarPowerConference.com





"Our customers require dependability. Our climate demands durability. Southwest Windpower wind turbines provide both."

Southwest Windpower Dealer Jim Norman, ABS Alaskan, Inc.

"The AIR X has been a breath of fresh air for small wind - powerful, simple to set up and operate, and very cost effective."

"The Whisper turbines are superb - quiet and exceptionally effective at low wind speeds, yet rugged enough to handle the extremes."



Fairbanks, AK (907) 452-2002
Anchorage, AK (907) 562-4949
Renton, WA (425) 251-5745
absAK.com

Visit our new website at windenergy.com

SERVICE • TECHNOLOGY RELIABILITY • SIMPLICITY

Why we sell more wind turbines than anyone else!

- ▶ 5 year warranty on Whispers and 3 year warranty on Air X.
- ▶ Continuous refinement of our products.
- ▶ Quieter machines that utilize new technology and simple design.
- ▶ Making wind energy easier with innovative tower designs.
- ▶ New manufacturing facility! We've moved into our new 28,000 sq. ft. facility to expand production and service.

Southwest Windpower
Renewable Energy Made Simple



1801 West Route 66
Flagstaff, AZ 86001 USA
Tel 928-779-9463 • Fax 928-779-1485
www.windenergy.com • info@windenergy.com

Discover™

Discover™ Deep Cycle
Sealed AGM and Gel Batteries For

Solar

Discover™ Professional series advanced AGM and Gel batteries for renewable energy applications are designed and engineered for reliability and dependability.

- Wind Generation
- Residential
- Remote Monitoring
- Communications

Discover™ the difference:

- 100% maintenance free. Never need to check electrolyte levels
- Equipment friendly; won't damage your equipment or work surfaces due to acid leaks, resulting in a clean environment
- Longer reliability and better performance provides you with more hours of green power
- Deep discharge and vibration protection
- Non-spillable by ICAO, IATA and DOT standards eliminating transportation restrictions

**L16
Sealed AGM
& Gel
Available**



Sealed L16-AGM

Sealed 30-AGM

Sealed Group 31-AGM

CENTRICPOWER

Dealer Inquiries
(951) 808-4736

www.centricpowergroup.com
discoversolar@centricpowergroup.com

SIMPLE Hot Water

Chuck Marken

©2005 Chuck Marken

SOLAR BATCH HEATERS



Author Chuck Marken and Don Keefe of AAA Solar rebuilt and reinstalled this Cornell batch heater.

My first experience with batch water heaters was almost 40 years ago, in Vietnam. Our company warrant officer was a savvy mechanic, and he made us a great water heater out of a scrounged wing tank from a fighter plane. He painted the tank black and put it up on some posts. We pumped water up to the tank. During the day, the black tank absorbed sunshine and, through conduction, heated the water in the tank. We took hot showers in the evening, after the workday had ended and the convoys had come in.

That wing-tank batch heater is emulated today in parts of Mexico. If you see a house with both a white and a black tank, chances are the black tank is a solar water preheater. In freeze-free climates, virtually nothing can go wrong with them—the simplest of all solar water heaters—except a lack of sunshine. Since the tanks are uninsulated and subject to ambient temperatures, after sunset these batch heaters tend to lose all the heat they gain during the day—hence the evening, instead of early morning, use of the hot water.

AKA Integrated Collector Storage

Batch heaters derive their name from how the water is heated—in a large batch, as opposed to collector-type circulation systems in which the water is heated continually

while passing through the collector. Batch heaters also are known as ICS (integrated collector storage) units, because the collector and tank are one and the same.

Most batch heaters are manufactured with a weatherproof enclosure (usually an aluminum or steel skin), up to 2 inches (5 cm) of polyisocyanurate rigid foam insulation on the back and sides of the box, and glass (typically double glazed) on the top, which faces the sun. All batch heaters are completely passive—they have no moving parts and require no additional energy inputs to operate. Two distinct types of batch heaters are available—the progressive tube and the single tank.

Progressive Tube Batch Heaters

At only 6 to 8 inches (15–20 cm) deep, a progressive tube batch heater can easily be mistaken for a regular solar collector. A typical progressive tube heater consists of an aluminum enclosure, insulation, glazing, and six to twelve, 4-inch-diameter copper tubes in the insulated enclosure. The 4-inch tubes are connected together inside the unit with $\frac{3}{4}$ -inch-diameter copper tubing.

The advantages of progressive tube heaters compared to single-tank batch heaters are usually a larger ratio of glass area to storage volume and less mixing of the incoming

Progressive Tube Batch Heater

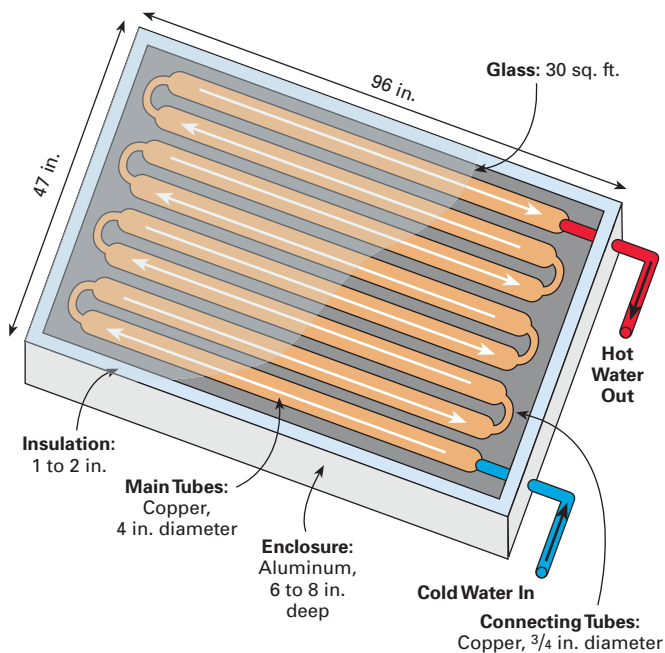

Single-Tank Batch Heater

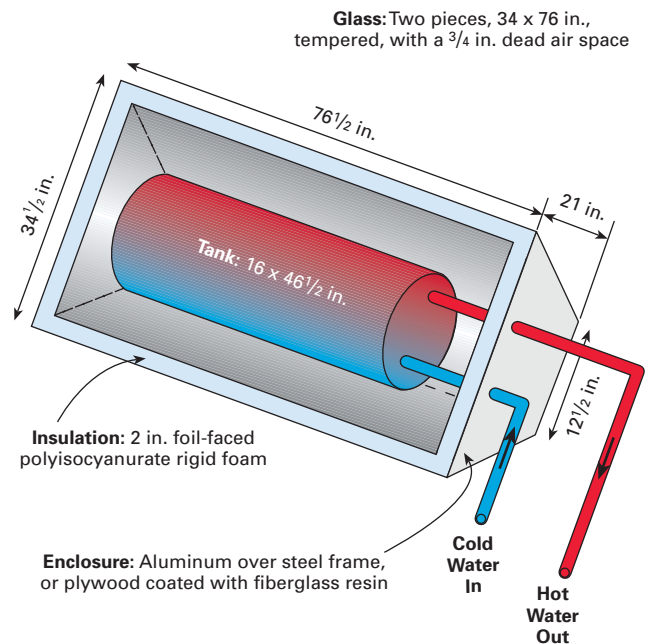

cold water. The more sunlight that hits the collector, the more energy that is available to heat the tank or tube; more glass area means more energy collected. Most progressive tube water heaters have a volume of about 40 gallons (151 l). The glass size for this much 4-inch tubing is about 30 square feet (2.8 m²), a ratio of 3 square feet (0.3 m²) of glass to 4 gallons (15 l) of water. Most tank batch heaters have a ratio of 1 to 2.

The multiple tubes in a progressive tube heater keep the hot water stratified much better than a single tank, delivering more consistent hot water to the taps or a backup heater. Progressive tube water heaters prevent the cold

water from mixing with the hot water—cold water enters the bottom tube and hot water exits the top tube. The weak point of progressive tube water heaters is the 3/4-inch tubing that connects the 4-inch tubes. All batch heaters have the piping to and from the collector as their Achilles heel, but the piping *outside* the collector can be protected with heat tape in colder climates. The smaller tubes inside the heater cannot be protected easily and, even in moderate climates, can freeze and burst during a hard freeze. Several bursts in piping inside a collector can sometimes make it economically unreparable.

Single-Tank Batch Heaters

Single-tank heaters usually have a smaller ratio of glass to liquid-storage, so the daytime heat gain and heat loss at night is not as great. In addition to being more tolerant of internal freeze damage, single-tank batch heaters also usually cost less—the difference being the cost of steel-lined tanks versus copper tubes. Generally, 40-gallon tank-type heaters cost less than US\$1,500, while 40-gallon progressive tube heaters *start* at US\$1,500.

The big advantage for many is that the simple construction makes this heater a good candidate for a low-tech, do-it-yourself (DIY) project. A DIY homebuilt, 40-gallon batch heater can be made for between US\$500 to \$600.

Build It Yourself?

A homemade single-tank batch water heater is a project for those with a medium level of DIY skills. If you fit this description, the drawing above will help you get started on the project.

Batch solar water heater in Santa Theresa, New Mexico.





The welded steel frame of a tank-type batch water heater.



Steel strapping holds the tank in the batch heater.



Adding glass and trim will complete the batch heater.

Probably the toughest thing for a do-it-yourselfer is fabricating the enclosure. Long-lasting enclosures for batch heaters can be made from wood, steel, aluminum, and fiberglass. Most batch heaters manufactured in the United States use an aluminum enclosure, but unless you have welding skills and access to inexpensive aluminum skin materials, you should probably stick with building a simple plywood enclosure. A coating of fiberglass resin on the exterior, and a layer of a good-grade exterior paint on both the interior and exterior surfaces will help the box last many years.

Foil-faced polyisocyanurate rigid foam insulation (available at most home improvement stores) is the best choice for insulating the heater because of its durability and ability to withstand high temperatures. (Lower temperature foam insulations, such as Styrofoam, are prone to melting.) Plus, the foil helps reflect sunlight onto the black tank.

You can fashion a storage tank by modifying an electric water heater tank. Strip off the insulation on the water heater, along with the exterior steel skin, and remove the elements along with the thermostats. (Most element ports can be sealed with a 1-inch-diameter galvanized plug.) Two, $\frac{3}{4}$ -inch-diameter pipe nipples, about 16 inches (41 cm) long, serve as the cold and hot pipes to and from the batch heater. It's as simple as cold on the bottom and hot on the top. Leave the dip tube on the cold inlet in the tank along with the anode rod. The dip tube will help stratify the tank water.

Old, used tanks are cheap—many times, free—but they can be a risky choice, since the older they are, the more prone they are to leaking. And changing a leaky tank in a batch heater is not an easy job.

For the glazing, low-iron tempered glass is recommended because it transmits 6 to 7 percent more light than regular glass. On a double-glazed collector, using low-iron glass increases the performance directly proportional to the amount of light transmitted—by 12 to 14 percent. If you can't find low-iron glass, you can substitute regular tempered glass. A common size that accommodates a 40-gallon batch heater is patio door glass, which measures 34 by 76 inches (86 x 193 cm). This gives a ratio of a little less than 1 square foot (0.09 m²) of glass to 2 gallons (7.6 l) of water, but still works well in milder, sunny climates.

Installation

Installation of either type of batch heater is straightforward and relatively simple, compared to active solar water heaters. The cold water from the home is piped into the bottom of the batch heater and the heated water exits from the top of the heater to the house. On progressive tube heaters, the cold inlet and hot outlet can be located on the same side of the heater or on opposite sides. On tank-type heaters, cold and hot always sit on the same side.

Hot water from the batch heater is piped to the cold inlet of a backup water heater. If the sun has heated the water, the conventional water heater thermostat senses hot water and the burner or element does not come on. If cloudy or inclement weather has limited the solar gain, the backup

Normal Piping with Isolation/Drain Valves

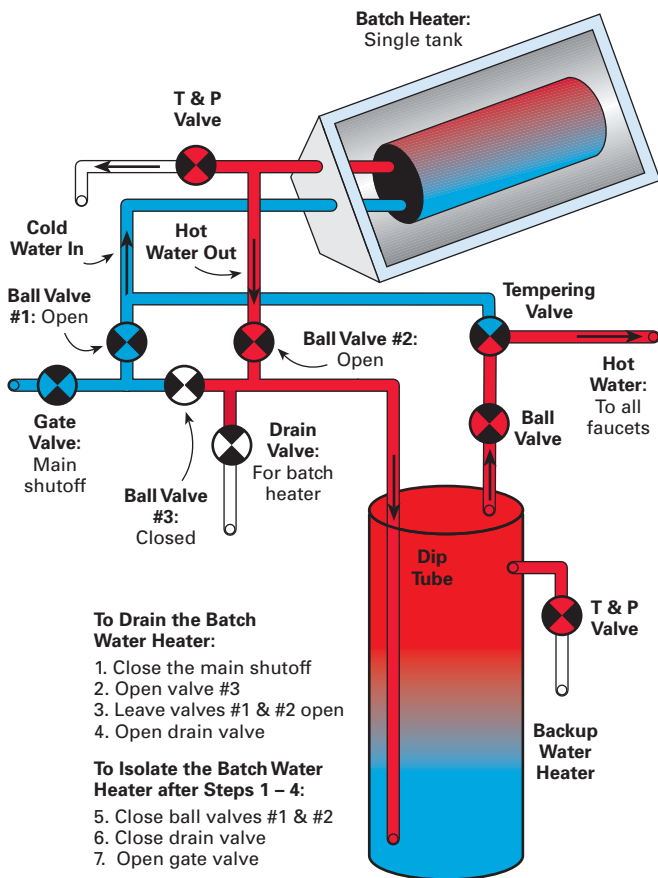

heater will heat the water to the set temperature. But even in cloudy weather, a batch heater can heat groundwater up to half of the desired temperature.

Batch heaters can be placed just about anywhere that has good solar access—on the ground or on the roof. Although the units can weigh up to 450 pounds (204 kg), the weight is distributed over such a large area that the load of a full water heater seldom causes problems for roofs. (Older mobile homes may need structural additions to support the load.) If the home's water system is unpressurized (gravity), the batch heater is normally placed on the roof.

If any valves are installed between the batch heater and backup water heater, the batch heater should have a pressure-relief valve. Isolation valves are usually included in batch heater installations too. The weak link in a batch system is the piping to and from the heater. If either or both pipes freeze, the home could be left with no hot water at all. Isolation valves can direct the cold water directly to the backup water heater until the frozen pipes can be thawed.

Limited to Milder Climates

Water stored in batch water heaters is subject to overnight ambient temperatures. Only two layers of glass and a dead air space separate the tank or tubes from outdoor air temperature—

as far as insulation goes, this isn't much. The colder the night, the colder the batch heater will get. This limits batch heaters to year-round use mostly in the southern United States—at 35 degrees north latitude or below. There are exceptions to this, of course—mostly based on altitude and coastal areas—but it's a good rule for most of the interior states.

A 40-gallon, tank-type water heater will not freeze in almost all of the lower 48 states—the volume is too large. But in cold climates, the batch heater will produce almost no usable heat in the winter. Progressive tube water heaters are not as tolerant. Their territory is generally limited to Florida, Texas, Arizona, Hawaii, and California.

Although batch heaters have limitations for year-round use in colder climates, they can be a good choice for seasonal use. Day camps, seasonal parks, and other summertime-use facilities can and do use batch solar water heaters. When the season is over, the tank and piping are drained and ready for the next year.

Batch-type solar water heaters are simple, reliable, and long lasting. Installation is easy and regular maintenance is nil. People who live in mild climates find that batch heaters, with their passive design, no moving parts, and relatively low cost, are an attractive option for solar water heating.

Access

Chuck Marken, AAA Solar Supply Inc., 2021 Zearing NW, Albuquerque, NM 87104 • 800-245-0311 or 505-243-4900 • Fax: 505-243-0885 • info@aaasolar.com • www.aaasolar.com

SunEarth Inc., 8425 Almeria Ave., Fontana, CA 92335 • 909-434-3100 • Fax: 909-434-3101 • sales&support@sunearthinc.com • www.sunearthinc.com • Progressive tube solar water heaters

Sun Systems Inc., 2030 W. Pinnacle Peak Rd., Phoenix, AZ 85027 • 800-777-6657 or 623-869-7652 • Fax: 623-869-0891 • info@sunsystemsinc.com • www.sunsystemsinc.com • Progressive tube solar water heaters

TCT Solar, 101 Copeland St., Jacksonville, FL 32204 • 904-358-3720 • Fax: 904-358-3728 • info@tctsolar.com • www.tctsolar.com • Progressive tube solar water heaters

Past articles on batch-type solar water heaters can be found in *HP93*, *HP84* & *HP76*



Coaxial Evacuated Vacuum Tube Solar Collector

SRCC Certified
Residential & Commercial
1kW thermal collector--\$935
Solar water heating
Radiant floor heating

www.btf solar.com

BTF Ltd. POB 409 Fennville MI 49408 USA
Tel. 269-236-6179 info@btf solar.com

SIMPLY THE FINEST SOLAR COLLECTORS UNDER THE SUN

- **DOMESTIC HOT WATER**
- **INDUSTRIAL APPLICATIONS**
- **RADIANT FLOOR HEAT**
- **POOL HEATING**

Attractive Design & Quality Manufacturing Assures Strong Sales & Reliable Performance

Contact Eric Hawkins, Apricus Agent/Designer
powertechsolar@btconnect.com

Apricus

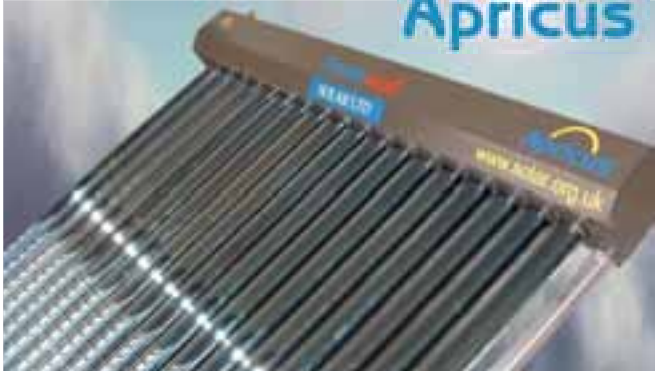

"SOLAR WAND"

SOLAR ASSISTED HOT WATER

Closed Loop Antifreeze System



"Solar Makes Dollars and Sense"
Energy - Savings Pay For System
Employment - Create American Jobs
Environment - Reduce CO₂ Emissions

Straight Forward Installation, Single Pump,
 40 Sq.Ft. of Solar Collectors, Either ACR Fireball
 2001, Double Glazed/Selective Absorber (Shown)
 or Thermomax Evacuated Tubes (Not Shown).
 Kits Including Anti-Scald Valve From \$2,700

www.butlersunsolutions.com

SOLAR WAND
 "Solar Wand"
 Double-walled
 heat exchanger
 screws into
 your tank

OG-300

Certified

Butler Sun Solutions

Since 2003 *"Dedicated to conserving the earth's energy and water resources."*

858-259-8895

***Patents Pending**

SOL-RELIANT™

The Solar Water Heater Built To Last



- No freezing!*
- No overheating!*
- No phantom loads!*
- No parasitic losses!*
- No visible plumbing!*

- Solar-powered pump.
- Design life: over 25 years.
- OG-300 and Bright Way certified.

- Easy to install and reinstall after reroofing.
- Dealer inquiries welcome.

Tax credits and rebates in some states pay up to half the cost!

Call (888) SOL-RELY

www.SolReliant.com

Gobi Solar Collector

Sought after for lasting high performance

Check out our easy packages for residential & commercial water, home or pool heating systems



Off-the-shelf and custom packages. Helio-Pak systems for all climates and applications.

2.25 KW per Gobi 410 standard rating. Strong and durable. Built-in mounting flange, modular easy flush and rack mounting hardware. Three convenient sizes.



Sensible Technology since 1976



HELIODYNE, INC.
4910 SEAPORT AVE, RICHMOND CA 94804
TEL: (510) 237-9614, FAX: (510) 237-7018
info@heliodyne.com



SUNEARTH inc.
Quality Solar Energy Products

**THINK THERMAL-
THINK SUNEARTH**



The CopperHeart Integral Collector Storage System

www.sunearthinc.com

SunEarth, Inc.

8425 Almeria Avenue, Fontana, CA 92335
(909) 434-3100, FAX (909) 434-3101
Distributor inquiries welcome.

THERMOMAX.COM

THE SOLAR WATER HEATING SOURCE



Thermomax Evacuated Heat-Pipe Solar Collectors
Thermo Technologies Temperature Differential Controllers
Stieble Eltron Solar Tanks

Please visit www.thermomax.com for our services and products

5560 Sterrett Place, Columbia, Maryland 21044

E-mail: info@thermomax.com

Phone: (800) 7SOLAR7, (800) 776-5277

**P
O
W
E
R**



Sometimes it takes a while for a dream to come true—like 30 years. As an aspiring architecture student in the late 1970s, I designed a fictional passive solar home on the west side of a remote island in the San Juan Islands, a diverse archipelago off the coast of Washington State. I had never visited the site, but maps showed it faced southwest, sloped gently to the south, and didn't have a lot of trees. It was a perfect site for solar energy, but it was just a project, and of course never got built. I played around with the active and passive renewable technologies of the time, eventually graduated with both a bachelor of arts and a master's degree in architecture, and moved forward with my career.

**T
O
W
E
R**

With Sun & Wind

Lisa C. Kennan-Meyer, AIA

©2005 Lisa C. Kennan-Meyer, AIA

My college thesis advisor once told me that he felt young architects should be required to build their projects with their own money so they could make the tough decisions they expect clients to make. Interspersed between my clients' projects over the last two decades, I have developed several of my own projects and have had to make some hard decisions.

In 1994, with a family and an established architecture practice, my husband John and I decided it was time to purchase some getaway property. With John's background in construction and project management, the two of us comprise an entire design-build team, so we felt confident that purchasing undeveloped land was a good value for us.

Our search for property took us all over western Washington State. Waterfront was the primary criterion, with the next one being privacy. We live on a small lot in an older, established Seattle neighborhood, and we wanted a getaway that was just the opposite. We also wanted easy access, so we could use the property on weekends year-round.

We made our first trip to Guemes Island on a beautiful autumn day. Crossing Guemes Channel on the twenty-car, open-deck ferry, we wondered why we had never been there before. Guemes is one of the easternmost islands in the San Juans. We fell in love with and eventually purchased six acres of dramatic, steep, heavily forested, east-facing hillside. On our land, a series of flat benches are interspersed with breathtaking rock outcroppings.

Moving Toward Renewable

The property had no utilities, so after building a road and digging a well, we turned our focus to getting electricity. Until we had some form of reliable electricity in place, we would not be ready to build our house.



The crew at the top of the tower's first section gets ready to receive and bolt the second section into place.

The nearest electrical lines were a quarter of a mile away. I was bothered by the look of above-grade wires and poles, and also knew they had a reputation on the island of being hit and put out of commission by falling trees. So we investigated the cost of trenching through the rock to bury electrical line to the specification required by the local utility. This cost—more than US\$30,000—prompted us to investigate renewable energy (RE) sources.

At first glance, solar energy did not seem viable because of our heavily forested, east-facing site, but we purchased one BP 80-watt photovoltaic (PV) panel to experiment with. We used it to charge our trailer's battery, and virtually eliminated the need to run our generator throughout an entire summer season. This success spurred us to further investigate RE technologies.

Then we discovered that Ian Woofenden, an RE consultant (and senior editor at *Home Power*), happened to live on Guemes. Ian visited the site, and walked the property with his Solar Pathfinder to assess our site's suitability for a solar-electric system.

Reinforcing steel and bolts were set into the foundation before pouring concrete.





A 50-ton crane lifted each assembled tower section into place. Amazingly enough, the first section lined up perfectly with the column bolts set into the concrete.

There was no moment of epiphany or assurance of how simple it would be to use renewables. Cutting down trees seemed to be inevitable to get any solar panels into the sunlight. Ian suggested wind power. At that time, I did not understand the perfect synergy of a PV–wind hybrid system, but in our rainy, northern, marine climate, sun and wind have an amazing reciprocal relationship. Our hillside site made us feel sheltered from the prevailing winds, but Ian thought wind was a good potential energy source for us. And, he said, once we built a tower to get the wind turbine above the trees, mounting a PV array on the south side of the tower could give us a viable hybrid system.

Our System Comes Together

With our interest in RE heightened, we signed up for classes offered by Solar Energy International (SEI). They teach workshops all over the world, but in yet another bit of synchronicity, classes would be offered that October (2003) on Guemes. During the “Introduction to Renewable Energy” workshop, we saw examples of wind, PV, microhydro, and other RE technologies. We were able to tour local installations of PV and PV–wind hybrid systems.

John took a weeklong PV class, and helped install a pole-mounted, 1,120-watt PV array and a homebuilt wind generator adjacent to Anderson’s General Store on Guemes (see *HP102*). After these experiences, we were hooked on the concept of renewables for our property, and told Ian that we would like to be the site of the projects for the 2004 SEI classes.

October 2004 seemed a long way off, but planning for the system started immediately. Besides working with the SEI team on the requirements and specifications of the hybrid system, we had to choose a tower, install infrastructure, apply for permits, and set aside the money to purchase all of the components. John estimated the loads for our planned home. We picked appliances out of catalogs and discussed what light fixtures to put into rooms that didn’t yet exist. We made a spreadsheet of all the appliances we’d power, and we calculated that a system that could produce about 9 AC KWH would meet our daily energy needs.

We were fortunate to have a whole host of RE specialists participate in this project. SEI instructor Mick Sagrillo offered his wind energy expertise, and

instructor E. H. Roy provided advice on the photovoltaic system. Kelly Keilwitz of Whidbey Sun and Wind designed our system and was our technical contractor for the two-week installation. Lance Moore, a licensed electrician, rounded out the professional team and handled the wiring work.

Building a Good Foundation (& Tower)

The choice of wind turbine and PV panels took a backseat to the most important element—the tower. If we didn’t get the components up into the sun and wind, energy generation was not going to happen. Major considerations

The complete AWP wind turbine was bolted to the tower’s top section prior to lift.



for the project were ease of installation and servicing the equipment on an island, overall cost, structural integrity, size, availability, and (of course) aesthetics.

After climbing, measuring, and siting from one of the tallest trees on the property, Ian felt that we needed the wind generator an absolute minimum of 120 feet (37 m) above the ground, with 160 feet (49 m) being an ideal height. This would ensure that the turbine would be above all turbulence—both now, and in the future as the trees grow. The higher the PV panels were out of the forest, the better they would perform too.

We researched both guyed and freestanding towers. Although we have a clear area at our site that serves as a required fire truck turnaround, this was nowhere near sufficient space to lower an assembled tilt-up tower. And the uneven, rocky topography and steep location did not lend itself to placing the multiple anchors required for a guyed tower. Our only choice seemed to be the more expensive freestanding tower.

We investigated the largest towers made for residential applications, and the smallest towers made for the telecommunications industry. We looked at monopoles and open truss. We weighed the benefits of new versus used. John and I had emotional discussions on whether to proceed with the project due to its escalating cost. But we had made a commitment to do an off-grid installation, and we both felt strongly about moving forward with the project. The cost of a scaled-back system would be a waste of money. It needed to be built as designed, or it was not worth doing.

Finally, we decided on a tower—a triangular-based, 160-foot-tall Eiffel Tower-style manufactured by Glen Martin Engineering. It was designed to handle a much larger wind generator and a larger PV array than we initially planned, so we could grow the system as we used our property more



With the wind generator installation complete, it's time to begin installing the PVs.

actively in the future. The marine environment required that it be resistant to corrosion. We investigated materials and settled on galvanized steel.

Before the class, the tower foundation had to be complete. We started in January 2004 for an October installation. Local county codes required that we complete a Washington State Environmental Policy Act review and obtain a building permit for the structure. Glen Martin furnished us with drawings and stamped structural calculations for the tower. I completed the site plan and environmental checklist. Possible concerns included noise from the wind generator, the turbine's potential impact on birds, and the impact of the tower on views. With performance data, calculations, and scientific journal information, we were able to respond to these issues to both the county's and our satisfaction.

Tower foundation construction started in May. John removed several trees and we determined the tower's exact location. The initial excavation required a hole approximately 20 by 20 by 10 feet (6 x 6 x 3 m) deep be cut out of the rock. The excavator was not big enough, and the hydraulic rock hammer broke down daily.

Kelly Keilwitz and E. H. Roy give SEI students instructions on the procedure for lifting the first array for placement on the tower.



Kennan-Meyer PV & Wind System

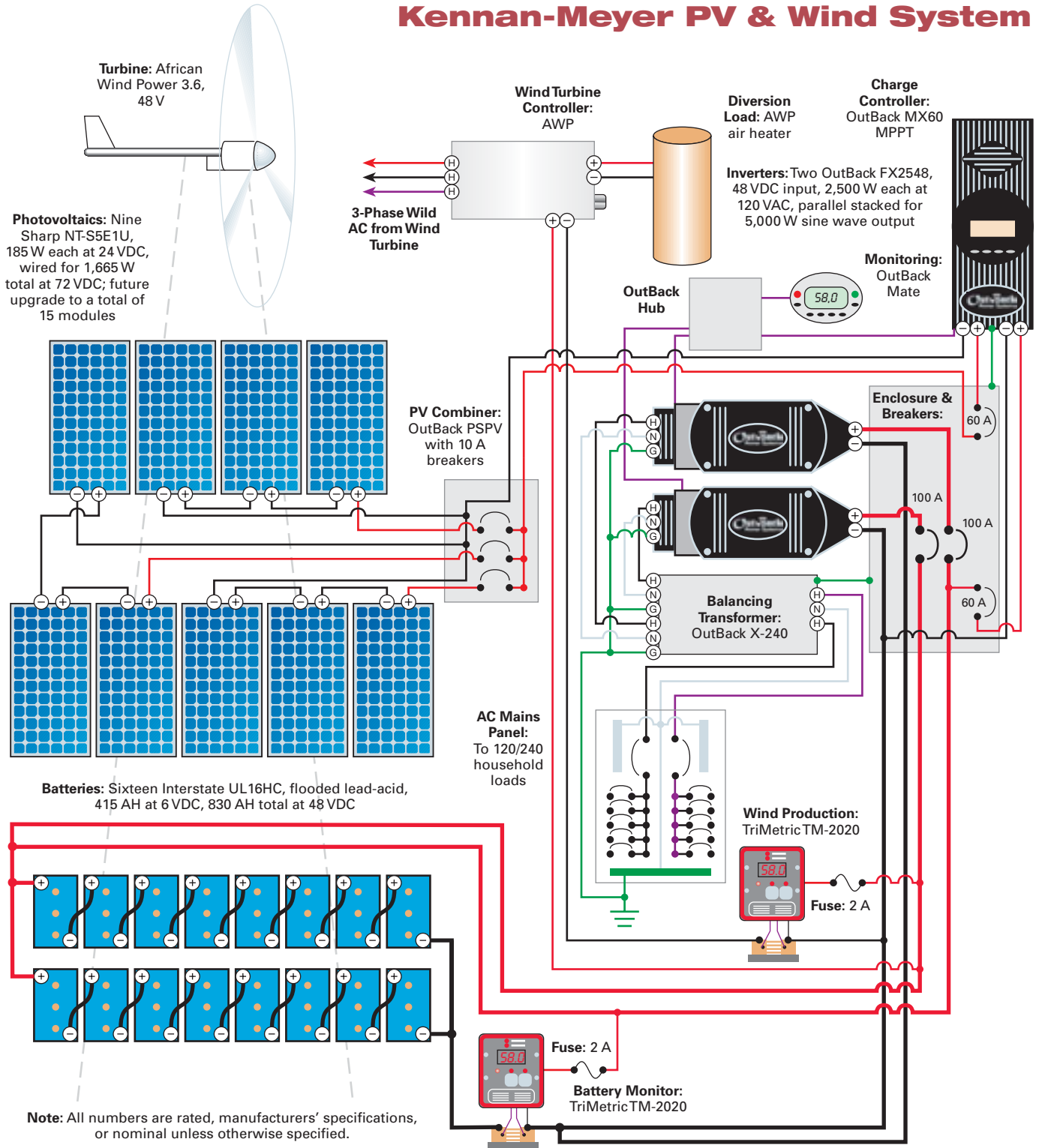

The foundation design provided by Glen Martin's engineer included #6 (3/4 in.; 19 mm) reinforcing bar on both top and bottom. Because the overturning load on the tower is so large, we rely on both the weight of the concrete and the weight of 6 feet (1.8 m) of rock ballast placed on top of the foundation to resist the force. Three round columns of concrete rise out of the foundation to support the tower legs. The tower sections would be lifted onto these legs,

and the 6-foot-long anchor bolts in each column had to be positioned perfectly for a tower that was not even on site, let alone complete. Templates for the anchor bolts provided by Glen Martin helped guarantee a perfect match.

The foundation used more than 60 cubic yards (46 m³) of concrete—more than what is used in most single-family homes in this region—and each load of concrete had to come over on the ferry. With the rock ballast in place, the

Kennan-Meyer PV & Wind Tech Specs

System Overview

Type: Off-grid, battery-based PV–wind hybrid system

Location: Guemes Island, Washington

Solar resource: 5.2 average daily sun hours (summer); 3.2 hrs./day (fall/spring); 1.9 hrs./day (winter)

PV production (AC KWH per day): Existing system—summer, 5.0; fall, 3.4; winter, 1.9. Future full array—summer, 8.3; fall, 5.6; winter, 3.2

Wind resource: 7 mph (3.1 m/s) annual average

Wind production (AC KWH per day): Summer, 0.5; fall/spring, 2.0; winter, 3.0

Photovoltaics

Modules: Nine Sharp NT-S5E1U, 185 W STC, 36.2 Vmp, 24 VDC nominal; future upgrade to a total of 15 modules

Array: Three, three-module strings for 1,665 W STC total, 108.6 Vmp, 72 VDC nominal; future upgrade to five strings for 2,775 W STC total

Array combiner box: OutBack PSPV with three, 10 A OutBack OBPV-10 breakers

Array disconnect: OutBack 60 A breaker

Array installation: Direct Power & Water custom design mount at 60 ft. tower elevation; south-facing, 63-degree tilt

Wind Turbine, Tower & Controls

Turbine: African Wind Power (AWP) 3.6, 48 V

Rotor diameter: 3.6 m (11.8 ft.)

Rated energy output: 220 DC KWH per month at 12 mph (5.4 m/s)

Rated peak power output: 1,000 W at 24 mph (10.7 m/s)

Tower: Glen Martin Engineering 157 ft. (47.8 m) freestanding lattice; with stub tower, turbine hub height at 163 ft. (49.7 m)

Wind turbine controller & diversion load: AWP 48 V

Energy Storage

Batteries: Sixteen Interstate UL16HC, 6 VDC nominal, 415 AH at 20-hour rate, flooded lead-acid

Battery bank: 48 VDC nominal, 830 AH total

Battery/inverter disconnect: Two OutBack OBDC-100, 100 A breakers

Balance of System

Charge controller: OutBack MX60, 60 A MPPT, 72 VDC nominal input voltage, 48 VDC nominal output voltage

Inverter: Two OutBack FX2548, 2,500 W each, 5,000 W total, 48 VDC nominal input, 120/240 VAC output; OutBack X-240 balancing auto transformer for 240 V loads

System performance metering: TriMetric TM-2020 battery monitor; TriMetric TM-2020 wind output monitor; PV datalogging via OutBack MX60

weight of the foundation is calculated at more than 325,000 pounds (147 metric tons)!

Installation Begins

The tower began as a pile of 20-foot-long steel tubes and a heap of steel angle-braces. Each piece had to be bolted together into what would eventually become leg sections. The legs were combined into two 60-foot-long (18 m) and one 40-foot-long (12 m), triangular tower sections. The height of the tower required us to use one of the largest cranes available locally.

The 3.6-meter-diameter (11.8 ft.) African Wind Power (AWP) turbine was removed from the box that shipped it from the factory in Zimbabwe. Class members attached the blades, constructed the tail, and mounted the stub tower. The top tower section would be lifted with the turbine bolted in place.

In four days of assembly, the tower was ready to be raised. Getting the crane up our narrow, steep, gravel road was challenging, but it rolled into the clearing. After a year of intensive preparation, the tower would finally be lifted into place. The first section was raised as the collective breaths of students and guests were held. It fit onto the eighteen anchor bolts perfectly, and students scrambled to tighten bolts.

Ian and the students climbed up the tower to receive the next section as it was lifted into place. Watching a 60-foot-tall, steel truss tower section fly through the air to line up with 1-inch-diameter (2.5 cm) bolt holes sounds impossible, but that's how it is done. Once the second section was secured, the remaining section was placed with the turbine at the top. The job was by no means finished, but the structure was up.



An OutBack charge controller and inverters are housed in the power shed, which is also home to a dump load, weather monitoring equipment, and the battery bank.

A 12- by 10-foot (3.6 x 3 m) power shed houses the inverters, charge controllers, dump load, battery bank and watering system, weather monitoring equipment, and other electronics. Conduit from the tower was routed into the shed before the concrete slab was poured.

The power shed was our Fourth of July weekend family project. The tower looms over the forest, and I wanted the shed to complement the tower and not look like a playhouse. The power shed design combines a simple plan and roof form with pleasing proportions and simple materials. The shed is insulated wood-frame construction with plywood panel siding and a galvanized aluminum channel roof.

The remainder of the workshop's second week was spent wiring the power shed. A large dry-erase board with the wiring schematic made the trip back and forth from the classroom to the power shed daily. On the last day of the workshop, the breakers were flipped and the displays in the power shed lit up. Everything was operational! We were generating electricity!

The Ease of PVs

After the complexity of the turbine and the precision of the tower, mounting the PV panels looked like easy work. The rack mounting system from Direct Power & Water was modified to accommodate placing the PV panels on the tower. Nine 185-watt Sharp PV panels were wired into three-panel, 72-volt nominal arrays. The panels step up the tower in a triangle, and the bottom two rows—with five and four panels each—are in place. The rows above—with three panels, two panels, and one panel, respectively—will be installed once the house is built. Due to cost concerns, we decided not to purchase and install all fifteen panels at once.

Other Infrastructure

We spent the rest of the two workshop weeks installing the electronics and the battery system. The 48 VDC nominal, 41.5 KWH battery bank will provide backup energy for about three days of foggy, calm conditions. After that, we usually have wind, or clearing and sun. If that doesn't happen, we can run an engine generator to charge the batteries.

System Costs

Item	Cost (US\$)
Tower (delivered); includes structural design fees	\$17,500
Foundation & backfill for tower	14,500
Sharp PV panels & custom mounting rack on tower	10,275
Wire, conduit, misc.	8,000
Power shed	5,500
OutBack equipment	4,575
Clearing & excavation for tower	4,500
AWP turbine, controller, diversion load & stub tower	3,500
Battery bank	2,875
Soils engineering & testing; permits	2,200
Crane (for tower erection)	1,800
Electrician	1,200
Battery watering system	775
Total Cost	\$77,200

System Performance

Overall, the system functions well. Our solar and wind energy production is exceeding the preliminary estimates and easily keeping our battery bank full. Since we do not have a house load on the system yet, the dump load is activating and consistently keeping the shed 10 to 20°F (6–11°C) above the outside air temperature. Eventually, the dump load will be used to preheat household water.

We chose a watering system from Battery Filling Systems (BFS) to help us take better care of the batteries. Without this system, we'd have to remove the caps of each battery by hand, check the water level, and add distilled water as necessary. The watering system we chose makes this tedious task much easier. The factory caps on the batteries were removed, and replaced with BFS threaded plugs equipped with floats. Clear PVC tubing runs from a small holding tank, which contains distilled water, to each plug. About once a month, we use a small hand pump to pressurize the tank, which then distributes water to top off the cells.

Off-Grid Living

When you live on the grid, you often take electricity for granted. With an RE system, you think about where every watt-hour comes from, and where you are using it. As my wise college advisor predicted, having—and paying for—my own RE system makes me able and willing to discuss renewables with clients, and encourages them to listen. I hope to incorporate the things we have done into future designs for clients.

Renewable energy is a choice, like any other component in a home. When people ask what the payback time for the system will be, I truthfully reply that I don't know. Most homeowners don't consider the payback time for a high-end, commercial-grade range or refrigerator, or custom cabinets—they put them in because that is what they want, and that is how they choose to spend their money. That's how I feel about our RE system, and I'm helping the planet as well.

Access

Lisa Kennan-Meyer, Kennan-Meyer Architecture, 5426 California Ave. SW, Seattle, WA 98136 • 206-938-1970 • Fax: 206-938-7499 • lisa@kennanmeyerarch.com • www.kennanmeyerarch.com

Abundant Renewable Energy, 22700 NE Mountain Top Rd., Newberg, OR 97132 • 503-538-8298 • Fax: 503-538-8782 • robert@abundantre.com • www.abundantre.com • U.S. distributor for African Wind Power (AWP) wind generator

Battery Filling Systems of the Americas, 5723 Country Club Rd., Ste. B, Winston-Salem, NC 27104 • 877-522-5431 or 336-946-0895 • Fax: 336-946-0897 • freeinfo@batteryfillingsystems.com • www.batteryfillingsystems.com • Single-point battery watering system

Bogart Engineering, 19020 Two Bar Rd., Boulder Creek, CA 95006 • 831-339-0616 • Fax: 831-338-2337 • bogart@bogartengineering.com • www.bogartengineering.com • TriMetric battery monitor

BP Solar, 630 Solarex Ct., Frederick, MD 21703 • 800-521-7652 or 410-981-0240 • Fax: 410-981-0278 • info@bpsolar.com • www.bpsolar.com • PV panel

Direct Power & Water, 4000 Vassar Dr. NE, Albuquerque, NM 87107 • 800-260-3792 or 505-889-3585 • Fax: 505-889-3548 • info@directpower.com • www.directpower.com • PV mounting rack

Glen Martin Engineering, 13620 Old Hwy. 40, Boonville, MO 65233 • 800-486-1223 or 660-882-2734 • Fax: 775-490-1300 • info@glenmartin.com • www.glenmartin.com • Tower

Interstate Batteries, 1700 Dixon St., Des Moines, IA 50316 • 866-842-5368 • customerservice@interstatebatteries.com • www.interstatebatteries.com • Batteries

Kelly Keilwitz, P.E., Whidbey Sun & Wind, 987 Wanamaker Rd., Coupeville, WA 98239 • Phone/Fax: 360-678-7131 • sunwind@whidbeysunwind.com • www.whidbeysunwind.com

Lance Moore, Lance Moore Electric, 5410 Coles Rd., Langlely, WA 98260 • Phone/Fax: 360-221-3280

OutBack Power Systems, 19009 62nd Ave. NE, Arlington, WA 98223 • 360-435-6030 • Fax: 360-435-6019 • sales@outbackpower.com • www.outbackpower.com • Inverters, charge controller, DC disconnect, breakers

E. H. Roy, 11 Roy Rd., Stewartstown, NH 03576 • 603-237-8194 • ehroy@usadatanet.net

Mick Sagrillo, Sagrillo Power & Light, E3971 Bluebird Rd., Forestville, WI 54213 • Phone/Fax: 920-837-7523 • msagrillo@itol.com

Sharp Electronics Corp., 5901 Bolsa Ave., Huntington Beach, CA 92647 • 800-SOLAR-06 or 714-903-4600 • Fax: 714-903-4858 • sharpsolar@sharpsec.com • www.solar.sharpsusa.com • PV panels

Solar Energy International, PO Box 715, Carbondale, CO 81623 • 970-963-8855 • Fax: 970-963-8866 • sei@solarenergy.org • www.solarenergy.org



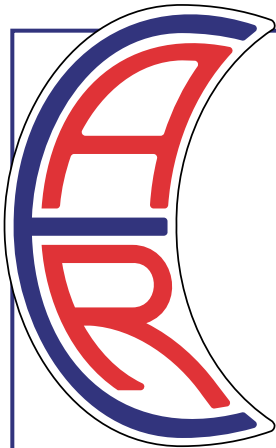

Residential Wind & Hybrid Systems from **Abundant Renewable Energy**

Introducing the **ARE110** and **ARE442** turbines in Fall 2005
See our website for the latest pictures and specs

- Maximizing Energy, by Maximizing Efficiency
- Direct Grid Connect without Batteries
- 24 & 48 volt Battery Charging Systems
- The Most Powerful Blades, the Most Efficient Alternators, and the Most Sophisticated Controls in the Field today.
- Quiet, Consistent, Reliable

Web Site: www.AbundantRE.com

Phone: **(503) 538-8298** • Email: info@AbundantRE.com

See web site for our list of dealers



Read about ARE installations of AWP3.6 turbines in *Home Power*:

AWP Review: #102, pg. 82

Direct Grid Tie: #100, pg. 22

Choose a Wind Generator:

#90, pg. 50



TCT SOLAR

Solar Water-Heating Systems

No pumps, No wires – Just Water Pressure & The Sun

www.tctsolar.com • 904.358.3720

ProgressivTube® - Obvious Technology

**ZAPSUCKER
.COM**



HuP[®] Solar-One[™] Batteries

Tired of Receiving **Broken Plastic Batteries?**

The **HuP Solar-One** battery is virtually indestructible because of the epoxy coated steel case! In fact Northwest Energy Storage will pay up to \$100.00 for any **HuP Solar-One** damaged in shipment.

Don't forget about the new reduced maintenance warranty, and paid service calls for all authorized **HuP Solar-One** dealers!

For information on the **HuP Solar-One** battery and our complete line of RE products contact:

Northwest Energy Storage

800.718.8816 or 941.697.1344 Fax 941.697.0767

www.nwes.com www.hupsolarone.com batteries@nwes.com

HuP Solar-One, The Better Built Battery[®]

**Dealer Inquiries Invited!
Many Models In Stock!**



Durable, high performance lighting and independent power solutions

Low wattage & long life lamps

- ✔ More than 25,000 operating hours
- ✔ Safe, low heat and almost unbreakable
- ✔ 2W and 4W at various DC voltages
- ✔ Soothing wide area illumination



Modular power system for emergency & off-grid living

- ✔ Withstand severe environment
- ✔ Integrated with gel battery and charge controller
- ✔ Rechargeable from PV & other sources
- ✔ Easy to install



all enquiry welcomed



info@grenzone.com
www.grenzone.com

Our Prices Are The LOWEST !
www.hydrogenappliances.com

Wind Turbine Blade Kits
As low as \$39.95

3 or 6 Blade Systems
Make our own wind turbines from a motor and 90 VDC motors !!! Made from strong carbon fiber! Each blade is 28" long. A very fast turning design!

Blade kits starting as low as \$39.95



58 inch diameter

Low Cost Wind Turbines Starting at only \$299.95 !

Wind Turbine Parts



Blades up to 33 inch diameter
Plastic
wood

Up to 1000 Watts

\$299.95

Bio-Diesel / Oil Supplies



- Filters
- Pumps
- Beds
- Hoses
- Housings
- Chemicals

- 12 volt
- 24 volt
- 48 volt
- 60 volt
- 90 volt

We sell PMA's for Wind and Hydro

ONLY \$499.95



1000 Watt
We also carry 340 volt and 24 volt



24 & 48 volt available
300 and 600 Watt models
12 Volt Water Heaters
Only \$29.95 - Great for diversion loads in wind and solar systems !!!



Our model #SEA50 charge controller works on all 12, 24 and 48 volt battery systems.
EE Battery regulation
Great for building diversion loads up to 400 amps, and costs only \$39.95 !!!
Make free hot water with your extra power. Battery regulated!

Lasts forever \$6.00 ea.

Buy factory direct
Forever Flashlight Never Needs Batteries
No bulbs or batteries to replace

Come see our web site for all details !
www.hydrogenappliances.com

Use our online shopping cart. Pay with PayPal or any major credit card! Quick and easy!

Best Pricing On The Net today!

Add to Cart
Thermodyne Systems
44447 Valley Cnt Way #222
Holiday Valley, CA 93536

HUTTON ...your wireless product experts

HUTTON OVERVIEW

MANAGE YOUR ACCOUNT

PRODUCT SEARCH

DESIGN A SYSTEM

SPECIFY INDUSTRY

MANUFACTURERS & SUPPLIERS

RESOURCE LIBRARY

NEWS & EVENTS

Hutton Solar

Where to find what you Design

huttonsolar.com
The best source to solar products distribution



Hutton Solar understands your time is valuable. That's why we provide real-time access to the best solar and solar-related products from the top manufacturers in the industry. Hutton Solar offers:

- The largest variety of Solar products from the top manufacturers in the industry
- A high-tech website for research & online ordering
- Technical application and design support
- Three regional warehouses for quick delivery

Looking for a Dealer /Installer in your area?

One of the most frustrating and time-consuming aspects of any project can be finding the right resources. With Hutton Solar's expansive dealer/installer network, we can connect you with the qualified experts who will get the job done right, coast-to-coast. Log on to Huttonsolar.com and use the "need a dealer in your area" feature on the home page, or call 877-648-8866 for personal assistance. Let Hutton Solar work for you!

www.huttonsolar.com • 877-648-8866

Solar, Wind, & Hydro

System Design & Product Sales
since 1985

Coming in July, our 16th edition
Planning Guide & Product Catalog – only \$5

We Accept



2086 US Hwy 93 N, Ste 130, Victor, MT 59875
1-888-SUNELCO • www.sunelco.com



Learn Some New Tricks...

Stop by the Sunelco booth
at the SolWest Renewable Energy Fair
in John Day, Oregon on July 29-31

Summer is here... temperatures are RISING...

TRISTAR™

THREE-FUNCTION SOLAR CONTROLLER
45A and 60A at 12-48vdc
UL LISTED

- our 60 amp version operates at 48V
- ours includes an RS-232 comm port
- ours accepts larger cable with more bending room
- our meter has much more information including graphics
- ours has a 5 year warranty
- ours fits on power panel
- ours is competitively priced!



yet the TRISTAR is still COOL!

...Much larger heat sink and proprietary thermal design keeps the TriStar operating at lower temperatures, increasing reliability and product life. Ratings are actual to 45°C (113°F). No need to derate.

 **MORNINGSTAR**
corporation

Phone: +1-215-321-4457
Fax: +1-215-321-4458
info@morningstarcorp.com
www.morningstarcorp.com

"This book is the solar thermal contractor's bible!"

SOLAR HOT WATER SYSTEMS

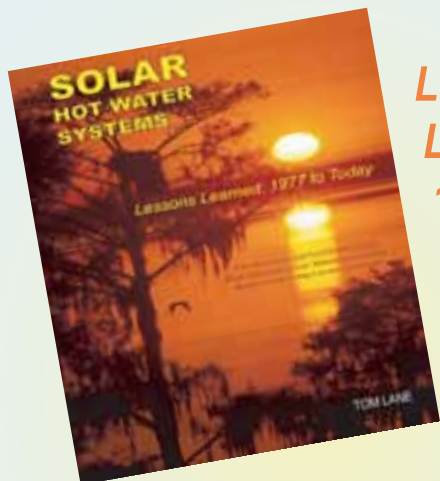

**Lessons Learned:
1977 to Today**

by Tom Lane

**Solar Hot Water & Pool Heating Design
High Performance-Low Maintenance Systems
Reality Checks Using Current Technology**

In this definitive 200-page manual, solar energy pioneer Tom Lane outlines how the latest technology and valuable lessons learned from the past can help a new generation of solar contractors expand their businesses and satisfy their customers.

DOWNLOAD NOW

Preview before you buy.
Download Table of Contents
and Chapter 2 ("Drainback Systems") at:

www.ecs-solar.com

Order online (www.ecs-solar.com) via credit card
or send check or money order to:

ENERGY CONSERVATION SERVICES

6120 SW 13th St. - Gainesville, FL 32608 - (352) 377-8866

Color edition: ___ copies @ \$50 each = \$ _____

Black & white edition: ___ copies @ \$29 each = \$ _____

Shipping & handling: \$ 4.00

TOTAL: \$ _____

**Save Up to 30 Gallons of Water
With Each Load of Laundry!**



**Only Top Load Horizontal-Axis Washer
Made in the USA--Great for Off-Grid Systems!**

- Avg. of 15 gallons of water & 1 oz. soap per load (great for wells & septic systems)
- Stainless steel inner & outer tubs
- Dual, re-greasable bearings on front & rear
- No front rubber gasket to worry about leakage or mildew
- Total front access to parts--*most simple design on the market*
- Simple, mechanical switches--no expensive electronic buttons!
- High extraction spin speed
- MADE IN THE USA!



Call 1-800-848-6200 to learn more!

www.staber.com

Staber Industries, Inc. 4800 Homer Ohio Ln Groveport, OH 43125



As seen in *HP 90*, pg 50
and *HP 103* pg 72
Dealer Inquiries
Welcome

PROVEN
PROVEN WIND TURBINES

**Direct Grid-Tie
Now Available**

Reliable • Quiet • Rugged • Elegant

Solar Wind Works

~ Proven USA Distributor ~

Chris Worcester, NABCEP Certified PV Installer
CA Contractor's License: #796322
NV Contractor's license: #59288

Renewable Energy Power Systems

- Sales—PV, Wind, & Microhydro
- Design—Off-Grid or On-Grid
- Installation & Service

Toll Free! 877-682-4503

PO Box 2511, Truckee, CA 96160

info@solarwindworks.com • www.solarwindworks.com





RUBBER SOUL

*Treading Lightly
with an Earthship Beauty*

Gary Duncan

©2005 Gary Duncan

Richly hued adobe plaster walls, Saltillo clay tile floors, and the kiva-style fireplace lend warmth and beauty to the Duncan home and belie the fact that the walls are constructed from used car tires.

At approximately 8,000 feet (2,440 m) in elevation, nestled at the base of the Sangre de Cristo Mountains in northern New Mexico, I built my energy efficient passive and active solar home.

My home is approximately 40 minutes north of Taos, in the small community of El Rito. It's an amazing setting on 5 acres with unobstructed panoramic views. The land has hundreds of juniper and piñon trees, mostly on the northern side of the property, with fewer trees on the southern side, which is ideal for the passive solar design of this house.

I knew I wanted to build a solar home, totally independent, and approximately 1,300 square feet (121 m²). Building a medium-sized home gave me the opportunity to build a custom home. The house seems larger than 1,300 square feet because of the open floor plan. I bought a set of generic plans from "earthship" originator Michael Reynolds at Earthship Biotechture in Taos, and worked on the construction of my home with the help of a crew.

An earthship is made of used tires and rammed earth, with high thermal mass and passive solar design features. I call my home a modified earthship. The basic plan is an earthship, but we did a few things that you do not see in a typical earthship. The glass on the south side of the dwelling is vertical, instead of slanted. I was afraid it would get too hot in the summer with slanted glass, and the home is very comfortable with vertical glass. We also made the home freestanding instead of built into the side of a hill or with a berm of dirt on the north side.

Worth the Wait

It took four summers to build this house, but it was worth the wait. I paid for it out of pocket, because I didn't want a mortgage. People shouldn't have to work 30 years to pay for their home. The advantage in taking longer to build is that you have plenty of time to think about how you want to finish your home.

I wanted the house to blend in with the environment. The color of the stucco is very close to the color of the soil in the area. The green window trim matches the color of the sagebrush. All the woodwork in the house is custom. The house has a lot of character and a warm feel to it. When you walk into it, you feel safe—this house will take care of you. All the doors are 2.5 inches (6.4 cm) thick, which adds to the massive feeling of the home.

The main building material of this home is rammed earth, using 475 discarded tires to hold the compacted soil in place that forms the main portion of the house. The remainder of the walls are adobe brick, with the exception of the wall dividing the bedroom and the bathroom, which is the only frame wall in the house. The tires are filled with dirt that is compacted with a sledge hammer until full, each weighing 300 to 350 pounds (136–160 kg) and 3 feet (0.9 m) wide. This is very labor intensive, so I made sure that I was out of town during this phase.

Passive Solar Features

After the electrician finished with the rough-in, the walls were covered with six layers of adobe (straw, dirt, sand, and water) until smooth. All the interior walls are either troweled adobe or adobe brick. The walls were coated with linseed oil to preserve and darken

them. When the sun hits the walls during the day, the dark walls absorb the heat. Then at night, the heat from the walls radiates into the home. It's a perfect system. With the sun lower in the sky in the winter, when we need more heat, it shines farther into the home, heating more of the walls. The Saltillo clay tile floors also heat up during the day.

Without any supplemental heating or cooling, the house doesn't get any warmer than 70°F (21°C) in the summer and no cooler than 63°F (17°C) in the winter. This is the most comfortable home I have ever lived in.

On the coldest mornings, I turn on the Empire ventless propane heater for a little while to get the chill off. When the sun comes up, the house warms up very quickly. The heater doesn't get used very much, but it's nice to have it when you need it. My propane use is minimal. Propane is used for the cookstove, water heater, and space heater. The bill for the year is US\$75. The 200-gallon (760 l) tank only needs to be filled every other year.

The kiva fireplace was built by the best builder in the area, Lincoln Landis, who builds his fireplaces to be as efficient as possible. The design directs more heat into the room instead of all the heat going up the chimney. Lincoln is a master of his trade. He always says, "Form follows function." The back walls are heated up by the fireplace and radiate heat into the house at night.

Insulation & Roofing

All the exterior walls have 2 inches (5 cm) of rigid insulation. The roof has two layers of 4-inch (10 cm) rigid insulation, an R-value of 60, covered by a PVC (polyvinyl chloride) roofing membrane that is light grey in color and helps reflect the summer sun, keeping the house cool.

I've been a roofing contractor for 34 years, and have installed almost every type of roof known—except one I saw on *National Geographic* somewhere over in Asia. The roof is a PVC single-ply membrane that is installed using a hot air gun to weld the system together. It is the best roofing system I've seen for a flat roof. It should last 50 years and it's easy to keep clean. Keeping the roof clean is very important if you have a water catchment system. You should choose a roof you can scrub clean from time to time, or be able to vacuum the dirt off your roof before it reaches your cistern.

Large, well-placed windows allow lots of natural light into the house.



Electrical System

After the tire walls were up, and the roof was on, Paradise Power Company, my solar-electric contractor, started to wire the house. Paradise Power was very easy to work with and took the time to make sure everything worked properly. They are a reputable company and were willing to come back, after they were paid, to double-check the system.

All the solar energy equipment was installed in the 10- by 12-foot (3 x 3.7 m) mudroom. The only items not in the mudroom are twelve deep-cycle batteries, which are located in an insulated box directly above the mudroom.

All the lights, ceiling fans, security cameras, and water pump run on DC (direct current) electricity. The remainder of the house is AC (alternating current) electricity. The renewable energy system includes six Kyocera, 120-watt photovoltaic (PV) modules; an OutBack MX60 charge controller; a Zomeworks PV tracker; twelve, 6-volt, 220-amp-hour Exide batteries; an Air-X wind generator on a 30-foot (9 m) tower; and a 12-volt Xantrex DR 2412 inverter with disconnect. The cost of the renewable electricity installation, which includes wiring the house, two ceiling fans, phone and stereo wiring, was about US\$16,000.

As far as appliances, they had to be super energy efficient and had to look good. The ConServ 375 refrigerator (US\$1,200) with a stainless steel finish was my choice. It is 78 inches high and approximately 26 inches wide (198 x 66 cm), with the freezing compartment on the bottom. Electricity consumption at 68°F (20°C) ambient temperature is 0.7 kilowatt-hours (KWH) per day. The unit is standard 120 volts AC.

The Equator, a combination washer-dryer (US\$890) is more energy efficient than conventional washer-dryers, and uses less water and less electricity (almost half that of conventional washer-dryers). Also, less detergent and bleach is needed to do the laundry, which saves our natural resources and creates less water and air pollution. The unit requires no outside venting. A solar dryer (clothesline) was installed outside, and gets a lot of use.

The Amana propane range (US\$900) is designed for high altitude. It looks like a commercial kitchen stove with its stainless steel finish with black trim. The AquaStar model 125S on-demand water heater (US\$700) can be used as a backup to a solar hot water system if desired.

Water Catchment & Recycling

A 1,500-gallon (5,700 l) cistern is used to catch water from the roof. The water is cleaned through a series of filters. It has been tested and is clean enough to drink, but I still use bottled water. When the water level gets low, I have well water delivered at the cost of US\$125 to fill the tank. I've only had to fill the cistern two times in three years.

The plumbing in the house is unique in that special attention was made to conserve water. A greywater system was installed. The water from the sinks and shower is piped to water the plants in an indoor planter. The water can be used a third time. After it percolates through the planter, it is pumped into the toilet before it reaches the 1,000-gallon (3,800 l) septic tank.

Comfortable Independence

I first heard of earthships at a presentation by Dennis Weaver in Boulder, Colorado. I was impressed, so I signed up for a workshop with Michael Reynolds in Taos, New Mexico. Shortly after the workshop, I bought the 5 acres and started to build while living in a 20-foot (6 m) camper.

One reason I was attracted to this kind of construction was that I wanted to build a home that would take care of me with little maintenance and allow a self-sufficient lifestyle. This home gives me all those things.

The author at his adobe-walled home.

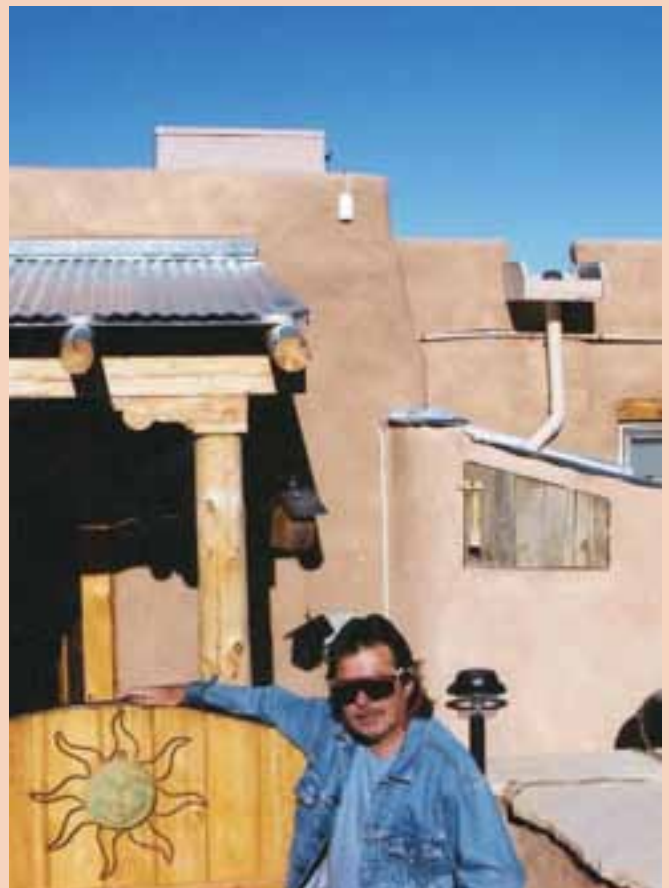



Almost 500 used car tires, filled with compacted earth, were used in the construction of the home's walls.

I have no mortgage, a US\$75 a year propane bill, water brought in to occasionally fill the cistern at US\$125 a year, insurance US\$700 per year, and taxes of approximately US\$600 a year. It makes for a pretty inexpensive existence.

Building this home has totally changed my life for the better. I now have a home that I can rely on in the uncertain future of rising oil prices and possible energy crisis, not to mention potential water shortages. Nothing can make a person feel more secure in life than to build a home like this.

I have always been an independent person. I don't like anyone telling me what to do, so I started my own business. I don't like utility companies charging whatever they feel like, and making me a slave to the "system." I don't like other people dictating to me how I should live. I'm not sure why more people don't use solar energy. It's a great feeling to be self-sufficient and independent.

Access

Gary Duncan • Phone/Fax: 505-461-1519 • duncanmoonshine@aol.com

Direct Power & Water, 4000-B Vassar Dr. NE, Albuquerque, NM 87107 • 800-260-3792 or 505-889-3585 • Fax: 505-889-3548 • dirpowdd@directpower.com • www.directpower.com • Energy efficient appliances

Earthship Biotecture, Michael Reynolds, PO Box 1041, Taos, NM 87571 • 505-751-0462 • Fax: 505-751-1005 • biotecture@earthship.com • www.earthship.com • Home design ideas

Lincoln Landis, PO Box 10 Taos NM 87571 • 505-776-2764 • Kiva fireplace

Paradise Power Co., Dan Weinman, 7484 NDCBU, Taos, NM 87571 • 505-737-5896 • paradise@taosnet.com • www.paradisepower.net • RE system installation

Taos Plumbing & Heating, Greg Millison, PO Box 742, Taos 87571 • Phone/Fax: 505-776-2228 • millison@taosnet.com • Plumbing contractor





Healthy Living Paints

Zero VOC Interior Paints, Clay-based Wall Coverings, Color Washes, Pigments and Milk Paints.
NEW! Aqua Resin Stain Finish Water-based, Zero VOC Interior/Exterior Wood Stains.



For a **FREE** Color Catalog call us at (800) 621-2591
www.bioshieldpaint.com

Inverter Service Company

a division of Direct Power and Water

- Authorized Service Center for Xantrex Inverters
- Authorized Service Repair and Sales of Mitsubishi UPS (7.5kva to 350kva)
- Certified Xantrex Dealer
- Largest inventory of SW, DR parts in North America
- Fastest turn around time in the WEST



Albuquerque, NM

Erich Lindner

Master Electronics Technician
erichl@directpower.com

Daniel Duffield

Electrical Engineer
dand@directpower.com

1-800-260-3792

www.directpower.com



Innovative Power Package features:

- Save installation time & money with plug-n-play design
- Patented, modular & pre-tested prior to shipment
- High quality system components
- Meets NEC-690 standards
- Grid-tie or stand alone power capability
- 16 models available - sized to meet your needs

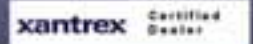

Planetary Systems, Inc.

P.O. Box 340 / 252 Badger Rd., Ennis, MT 59729

Phone (406) 682-5646 FAX (406) 682-5644

www.planetarysystems.com



ELECTRO AUTOMOTIVE

Electric Car Conversions Since 1979

Books ⚡ Videos ⚡ Kits ⚡ Components

- ⚡ **Catalog** Send \$6.00 for our catalog, or visit our web site.
- ⚡ **"Convert It"** We wrote the book on electric car conversions - literally! Send \$30.00 postage paid for this hands-on how-to conversion manual, written in plain English for the home hobbyist mechanic.
- ⚡ **Conversion Kits** Complete custom bolt-in kits for the VW Rabbit and Porsche 914, or a universal kit for other small cars and light trucks.
- ⚡ **Web Site** Visit our web site for our complete catalog, price list, gallery of conversions, and extensive conversion information section.

P.O. Box 1113-HP, Felton, CA 95018-1113 ⚡ 831-429-1989

WWW.ELECTROAUTO.COM ⚡ ELECTRO@CRUZIO.COM

Battery Filling Systems

Put the fun back in watering your batteries!



- One Connection
- One Minute
- Accurately Fills Each Cell, Every Time!

See Product Review, Home Power Magazine Issue 100, Page 82

Master Distributor for BFS, deep cycle & industrial batteries

All Battery Sales & Service



1-800-562-3212

Fax: 425 742-1739

vern@allbatterysalesandservice.com

You'll appreciate our ...

attractive design

simple handling

best quality



NEW

Solar Thermal Controller
Steca TR 0603
6 inputs, 3 outputs



Photovoltaic Charge Controller
Steca PR 1010, 1515, 2020, 3030
15 - 30 A

Steca GmbH
Mammostrasse 1
D-87700 Memmingen
Germany
Tel: +49 (0)8331 8558 0
Fax: +49 (0)8331 8558 12
www.stecasolar.com

Olympia, WA
800-685-7940

Santa Cruz, CA
800-635-7497

Temecula, CA
866-293-8876

Riverton, UT
800-671-0169

AK, HI & Eastern USA
800-667-6527

Harness the power of the sun



GREEN GRIDTIE solar power system

Complete power solutions for your home

www.spsenergy.com

Solid Investment
Solar systems will produce electricity far into the future.

Energy Independence
You will have a smaller bill from your utility.

Affordable Energy
Some utilities offer tax breaks, incentives and rebates to further reduce the cost.

Stewardship to a Cleaner Environment
Solar electricity reduces green house gases. The future is brighter with solar.

Introducing Two New CD-ROM Offers from **Home Power**...

Free Style.



Solar10 is the latest addition to *Home Power's* CD-ROM-based back issue archive.

Subscribe or renew for three years and we'll send you our new Solar10 CD-ROM free.

Save
\$29!

To order online, visit
www.homepower.com/subscribe

Three-year subscription/renewal pricing:

\$57.50 Standard delivery to any U.S. address
\$80.00 Surface delivery to any non-U.S. address

All for One.



That's 106 PDF back-issues and much, much more.
See homepower.com/CDset for complete contents information.

Get our complete CD-ROM archive,
17 years of digital *Home Power* for
just \$100.

Save
65%!

To order online, visit
www.homepower.com/CDset

Shipping & handling:

\$9.00/U.S., \$10/Canada, \$13/Other International

The logo for Home Power, with 'home' in a smaller font above 'power', both in a stylized, lowercase, sans-serif font.

Order online at the above addresses or call 800-707-6585 or 541-512-0201

All CD-ROMs contain original magazine layouts as published. Back issue files are provided in Portable Document Format (PDF)—searchable, exportable, and printable. Adobe Acrobat Reader required.

OFFER EXPIRATION DATE EXTENDED DUE TO POPULAR DEMAND



150 of the Best Articles on the Basics of Renewable Energy from the First 15 Years of Home Power Magazine.

\$29

Save \$10 on Solar1 or any CD-ROM when you subscribe or renew! Just \$19



Shipping: \$2 US, \$3 Can, \$4 Other Int.

Order by phone at 800-707-6585 or 541-512-0201 or online at www.homepower.com/subscribe



A Perfect, Paperless Alternative

Digital subscriptions* are available now! Download a year of *Home Power*—six bi-monthly issues—in Portable Document Format (PDF) for just \$15.

- Identical to our print edition
- Easy, on-screen navigation
- Built-in bookmarks and links
- Searchable and printable

To learn more or to get started, visit...

www.homepower.com/digital

* Requires Adobe Acrobat Reader 5.0 or later and an e-mail address.

Flow-Rite Pro-Fill

Battery Watering System

Ian Woofenden

©2005 Ian Woofenden

Application: We're using the Flow-Rite Pro-Fill battery watering system for the house-starting battery bank in our converted 1956 GMC bus.

System: The watering system consists of special manifolded caps for each battery, rubber tubing, connectors, and a squeeze-bulb hand pump.

Our battery bank is four Interstate UL16, flooded, lead-acid, deep-cycle batteries, with a total capacity of 9 KWH, or 4.5 KWH at 50 percent depth of discharge. The 6-volt batteries are wired in series-parallel for 12 volts. The batteries are charged by 620 rated watts of PV, the bus' alternator when it's running down the road, and the grid or our off-grid home system on occasion. The bus loads include a refrigerator, lighting, laptop computers and a printer, ventilation, and stereo equipment.

A Weak Link

I think of batteries as one of the three weak links in off-grid renewable energy systems (generators and humans are the other two). Flooded batteries are the only major component in a PV system that need regular maintenance, and all types of batteries will require periodic replacement.

Batteries are subject to abuse from overcharging, overdischarging, corrosion, and lack of maintenance.

The Flow-Rite Pro-Fill caps, manifold, tubing, and fill tube (pump not shown).



A good charge controller prevents overcharge. A battery state of charge (amp-hour) meter and user awareness prevent overdischarge. Good connections and using a battery terminal coating prevent corrosion. And although a battery watering system doesn't eliminate the major maintenance chore, it makes it easy, so it gets done.

Maintenance Made Convenient

While my bus system only has four batteries, the Pro-Fill system allows you to fill up to eight, 6-volt batteries to proper electrolyte levels from a single fill tube, using the simple hand pump. Without this system, you'd have to water 24 individual cells by hand, a time-consuming task.

In the system, three battery caps are connected with one manifold, to fill the three cells of a 6-volt battery. A variety of manifolds are available to fit your specific battery type and size. These replace the original battery caps—just pop the manifold into the battery fill holes and twist the caps down.

The top of the manifold has a three-way fitting with barbed ports that accept $3/16$ -inch rubber tubing, also included in the kit. The tubing slips over the ports and allows you to connect the water-filling system to the batteries in a variety of configurations. All you need is a sharp knife or pair of scissors to cut the tubing to length. Unused manifold ports are sealed with small caps that come with the kit.

Another length of tubing runs from one of the tees to a quick-release fitting with a protective cap, which keeps the tube-end clean when not in use. A separate hose, with the squeeze pump integrated into its middle, fastens into the other side of the quick-release fitting for watering.

Operation

Using the Pro-Fill system couldn't be easier. Take a jug of distilled water to the battery bank, remove the protective cap on the end of the quick-release fitting, and snap the fill hose into the fitting. Put the loose end of the hose into the jug, and start pumping.

The secret to this simple system lies in the battery cap. In each one, a valve connects to a hollow plastic float, which sits in the electrolyte. As water is pumped into

the cell, the float rises. When the cell is full, the float closes the valve, preventing more water from entering. When the whole bank is full, you won't be able to pump anymore.

The pump moves a surprising amount of water in a short time. Normal watering of our bus battery bank takes fewer than a dozen squeezes of the pump. When I'm done, I disconnect the hose; drain, coil, and store it; and put the protective cap on the battery end of the quick-connect fitting. Then I'm finished with battery watering for another few months. I never need to open the battery caps, so no contamination is possible.

Handy Maintenance Tool

Our bus battery bank sits in a small compartment, which we tried to fill as full as possible with batteries, so we have the largest capacity possible for our bus loads. Manually watering this battery bank would be tough—requiring a flashlight, a mirror, and a long funnel. It would be messy too, and time-consuming.

The Pro-Fill system makes this task easy, clean, accurate, and safe. But you don't need an inconveniently sited battery bank to make it worth your while to invest in a battery watering system. All but the tiniest battery banks will benefit from having a watering system. It simplifies the primary battery maintenance task, which makes it more likely that you will take care of this important job on a regular basis.



Zander Woofenden filling the bus battery bank with the Pro-Fill battery watering system.

Features

High Points:

- Complete kit
- High-quality components
- Simple to install
- Moderate cost
- Prevents over- and under-filling
- Avoids battery contamination
- Makes battery maintenance accurate, easy, and convenient

Low Points:

- Not automatic
- No hydrometer access

List Price:

US\$140 for system tested (12 cells), including pump

Warranty:

5 year on valves; 1 year on pump

Pro-Fill is Flow-Rite's line for RVs, boats, golf carts, and other consumer applications. The company also makes an industrial-grade battery watering system, their Millennium SPW line. It includes a flip-top cap for hydrometer access. Flow-Rite's Qwik-Fill line is for 12-volt batteries—automotive, marine, etc.—and services the six cells with two manifolds.

Some people who want to minimize system maintenance buy sealed batteries. This can be a good choice in some applications, but sealed batteries are more costly, take more care in charging, and typically don't last as long. Buying a battery watering system is a good option in many cases. It gives you the economy and conventionality of a flooded lead-acid battery, with very easy maintenance.

Buying and owning a renewable energy system is an investment in your money and time. Anything that makes taking care of your investment easier is worth a good look. The Pro-Fill system is modestly priced, simple to install, and convenient to use. For my money, it's a no-brainer for any renewable energy system using flooded batteries.

Access

Reviewer: Ian Woofenden, PO Box 1001, Anacortes, WA 98221 • ian.woofenden@homepower.com

Manufacturer: Flow-Rite Controls Ltd., 3412 Lousma Dr. SE, Grand Rapids, MI 49548 • 616-243-2750 • Fax: 616-243-5151 • sales@flow-rite.com • www.flow-rite.com

Distributor: Jan Watercraft Products, 13354 Greenleaf Ln., Grand Haven, MI 49417 • 616-822-7587 • Fax: 616-846-3006 • sales@janwp.com • www.janwp.com



The BEST Tool for Solar Site Analysis

Easy to Use



Ingenious design projects your horizon onto a sun chart for the full year.

Perfect for optimal siting of:

- Photovoltaic Arrays
- Solar Hot Water Systems
- Solar Homes
- Greenhouses
- Gardens

Includes sun paths from 0–66° North & 0–49° South. With metal case & tripod \$255, Handheld \$175, (+S&H).



Fast & Accurate

3953 Marsh Creek Road
Linden, TN 37096

info@solarpathfinder.com • Fax 931-589-5400



SolarPathfinder
FAST ACCURATE SOLAR SITE ANALYSIS

www.solarpathfinder.com

SOLECTRIA RENEWABLES

Grid-Tied PV Inverters

Lightweight & Efficient Design
Plug 'n Play Installation
Unsurpassed Quality
Breakthrough Price

360 Merrimack St.
Lawrence, MA 01843
tel: 978-683-9700 fax: 978-683-9702

PVI2500 Residential PVI1800 Residential

www.solren.com inverters@solren.com

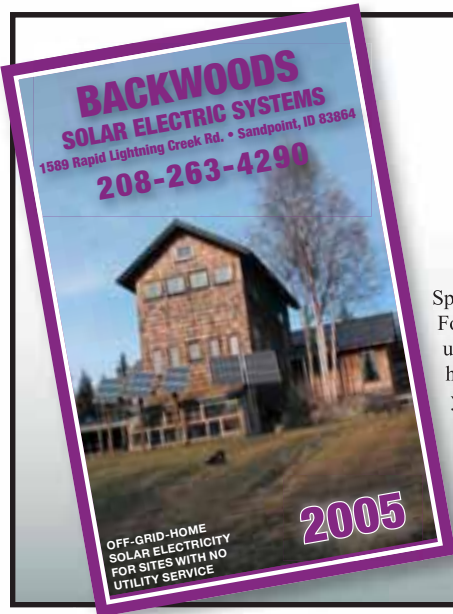

BACKWOODS Solar Electric Systems

For an earth restored and a world at peace.
Solar • Wind • Hydro

Specializing in Independent Electric Power for the Remote Home where utility power is not available. For 26 years, your questions have been personally answered by the good folks at Backwoods Solar that use these products everyday. Our catalog / planning guide teaches the basics of installing solar, wind and hydro electric residential power and we offer free system design service either by telephone, email, or your visit to Backwoods. We can also refer you to solar helpers around the country.

**185 PAGE
CATALOG / PLANNING GUIDE**
Free to *Home Power* readers
in the U.S.A.

Visit us or write:
Backwoods Solar Electric Systems,
1589-HP Rapid Lightning Creek Rd,
Sandpoint, Idaho 83864 USA

Phone: (208) 263-4290 • Fax only (208) 265-4788

Website: www.backwoodssolar.com • Email: info@backwoodssolar.com

Renewable Energy Technologies

DIPLOMA SERIES

A diploma program that provides you with valuable hands-on, practical interdisciplinary and specialized education in renewable energy technologies:

- Basics of Green Building Construction
- Wind Power
- Solar Thermal Systems
- Photovoltaics
- Biomass and Biofuels

NC STATE UNIVERSITY



Take any three of these four sessions you like.

- RE IV: August 29-September 2, 2005
- RE I: October 31-November 4, 2005
- RE II: March 13-17, 2006
- RE III: May 15-19, 2006

Please use the priority code REHP when registering by telephone or on-line.



REGISTER TODAY! On-line at ContinuingEducation.ncsu.edu,
Call 919.515.2261, or Fax your registration form to 919.515.7614



SOLARTRAX™
POWER STATIONS
From 1 kW to 5.2 kW



5208-8P (1.5 Kw)

**Solar Power
Tracking Stations**

The S-400 with battery back-up at a residential location (5.2 kW)

Official Distributor of: 

For Residential, Commercial and Remote Applications

www.solartrax.com 619 Commercial Ave. Covina, California 91723 Phone 626 331-9570 Fax 626 331-8584

The 2008 NEC

Changes to the *National Electrical Code*

John Wiles

Sponsored by the Photovoltaic Systems Assistance Center,
Sandia National Laboratories

Proposals for the 2008 *National Electrical Code (NEC)* are due to the National Fire Protection Association (NFPA) in early November 2005. A team of more than 50 volunteers is developing, reviewing, and coordinating these proposals. Half of the current proposals are outlined below. The second half will be presented in the next issue of *Home Power*. If you want to see the entire list now and keep abreast of any changes, the current set of proposals may be downloaded from the SWTDI Web site (see Access).

690.2 Definitions (New)

Proposal: Add the following new definition to 690.2:

Connector, Locking. A connector that requires a tool or other device to open.

Substantiation: Defines a term used in 690.33(C).

690.5 Ground Fault Protection (Revised)

Proposal: Revise 690.5 as follows:

690.5 Ground Fault Protection. Grounded DC photovoltaic arrays shall be provided with a DC ground-fault protection device meeting the requirements of 690.5 (A) through (C). Ungrounded DC photovoltaic arrays shall comply with 690.35.

Substantiation: Recent events and analyses of PV systems and various types of ground faults and circulating ground-fault currents have revealed the necessity of requiring these fire hazard reduction devices on all PV arrays, not just PV arrays on the roofs of dwellings. Ground faults in PV source and output circuits can carry current continuously without tripping overcurrent devices. It is not possible to place an overcurrent device in a circuit conductor (either grounded or ungrounded) that can interrupt these ground-fault currents without affecting the ability of the circuits to carry normal and expected operating currents. Certain unique aspects of PV modules, subarrays, and arrays, and the ability to generate sustained ground-fault currents dictate that these ground-fault currents are sensed and interrupted at a level of no more than 5 amps. This minimizes the need for significant oversizing of equipment-grounding conductors. Ground faults involving arcing-fault currents will also be held to this value or less.

690.5(A) Ground-Fault Detection and Interruption (Revised)

Proposal: Revise 690.5(A) as follows:

690.5(A) Ground-Fault Detection and Interruption.

The ground-fault protection device shall be capable of detecting a ground-fault current at levels of 5 amps or less, interrupting the flow of fault current, and providing an indication of the fault.

Automatically opening the grounded conductor of the faulted circuit shall be permitted to interrupt the ground-fault path. If a grounded conductor is opened to interrupt the ground-fault path, all conductors of the faulted source circuit shall be automatically and simultaneously opened. Manual operation of the main PV DC disconnect shall not activate the ground-fault protection device or result in grounded conductors becoming ungrounded.

Substantiation: See the substantiation for 690.5. The 5-amp level is consistent with IEEE standards on ground faults. The 5-amp level will not result in false trips on older PV arrays that may have distributed ground leakage currents of several amps in rainy weather. Ground-fault devices for small PV systems (up to about 10 KW) will continue to have ground-fault sensing levels in the 0.5 to 1 amp range.

The second paragraph is moved from 690.5(B) to 690.5(A), where it properly describes the various optional methods of interrupting the fault current as required by 690.5(A).

The addition of the last sentence in the second paragraph prevents interconnecting the main DC PV disconnect with the ground-fault protection device, which could leave the PV array ungrounded when the PV disconnect was opened manually during normal service operations or in other situations. This wording also parallels the wording used in 690.35(C)(3) for ungrounded systems.

690.5(B) Disconnection of Conductors (Revised)

Proposal: Revise 690.5(B) as follows:

(B) Isolating Faulted Circuits. The faulted circuits shall be isolated by one of the two following means:

- The ungrounded conductors of the faulted circuit shall be automatically disconnected.
- The inverter or charge controller fed by the faulted circuit shall automatically cease to export energy.

Substantiation: Revising the title from “Disconnection of Conductors” to “Isolating Faulted Circuits” more accurately reflects the intent and actions of the section. An inverter that ceases to export energy, or disconnected ungrounded conductors of the faulted source circuit, both give the same desired effect: The faulted PV circuit produces no power, and the lack of output power provides additional safety and an additional indication that there is a problem. UL is currently listing inverters that cease to export energy under ground-fault conditions as meeting this requirement as written in the 2005 *NEC*. A similar requirement would apply to charge controllers if the first option is not used.

The rewording allows the code requirements to agree with the existing listed hardware.

690.10(A) Inverter Output (Revised)

Proposal: Revise 690.10(A) as follows:

(A) Inverter Output. The AC inverter output shall be permitted to supply AC power to the building or structure service disconnecting means at current levels less than the calculated load of that building or structure. The inverter output rating or the rating of an alternate energy source shall not be less than the largest, single, connected load. General lighting loads shall not be considered to be a single load.

Substantiation: Stand-alone PV systems (PV array, inverters, batteries) are designed and operated based on the available solar energy. Energy conservation by the users allows the supplied buildings or structures to be operated on significantly less power and energy than would normally be used in similar buildings. While the building wiring should meet all code requirements from the main service disconnect through the branch circuits for safety reasons as required by 690.10, the power and energy supplied by the PV system needs to meet only the actual use requirements of the building.

Although not a safety issue, good system design dictates that the electrical system is able to start and run the largest connected load. Many systems have an alternate energy source (backup or standby generator) that is used routinely to start and run larger connected loads. Either the inverter or the alternate energy source should be rated to start that single, largest connected load. Because lighting loads (3 watts per square foot) are under the direct control of the users, are intermittent in nature, and may be reduced to zero as desired, they are not considered a single load.

690.10(D) Energy Storage Requirements (New)

Proposal: Add the new section 690.10(D) as follows:

690.10(D) Energy Storage Requirements. This code does not require any minimum size for the energy storage system in a stand-alone photovoltaic power system.

Substantiation: Stand-alone PV systems (PV array, inverters, batteries) are designed and operated, based on the available solar energy. Many stand-alone PV systems are directly connected to the loads without any energy storage (for example, water pumping systems). Users of systems with energy storage manually adjust energy usage to match available solar energy and the size of the energy storage system. Energy use may be reduced to zero or near zero during extended periods of cloudy weather, or a backup energy supply may be used. Specifying some minimum size for the energy storage system is not practical given the numerous variables, nor is such a specification an electrical safety issue.

690.10(E) Backup Power System (New)

Proposal: Add the new section as follows:

690.10(E) Backup Power System. This code does not require any backup power system in a stand-alone photovoltaic power system.

Substantiation: See the substantiation for 690.10(D). Many stand-alone PV systems do not employ backup power systems. Specifying the requirement for a backup power system is not practical given the numerous variables, nor is such a requirement an electrical safety issue.

690.13 Switch or Circuit Breaker (Revised)

Proposal: Revise the second sentence of 690.13 as shown with the exception. The first sentence and the FPN [fine print note] remain unchanged.

690.13 All Conductors. A switch, circuit breaker, or other device shall not be installed in a grounded conductor, either AC or DC, where operation of that switch, circuit breaker, or other device may leave the marked grounded conductor in an ungrounded and energized state.

Exception: A switch or circuit breaker that is a part of a ground-fault detection system required by 690.5 and where that switch or circuit breaker is only automatically opened and indicated as a normal function of the device in responding to ground faults.

Substantiation: Other sections of the code (240.22) allow a multipole overcurrent device to open a grounded conductor. This allowance is acceptable in a load circuit where the disconnected and now ungrounded conductor becomes unenergized when it is disconnected from the source of energy. However, in many power source circuits, such as DC PV source circuits and AC generator or inverter output circuits, the grounded circuit conductor is usually bonded to ground at a central location on the load side of any disconnecting means. If the disconnecting means or overcurrent device opens the grounded circuit conductor, then that conductor (marked as a grounded conductor) may be energized and ungrounded. This is an unsafe condition. This proposal addresses the issue for PV circuits (AC and DC), where these types of source/supply circuits may be more common than elsewhere, and prevents the ungrounded conductor from being opened under normal operation.

The exception is slightly reworded to allow the grounded conductor to be opened when, and only when, opened as an

automatic function of a code-required ground-fault device. This clarified requirement will ensure that 690.5 ground-fault protection devices are not included as part of the main user-accessible PV disconnect switch that could open a grounded conductor or unground the PV array under normal, manual shutdown operations.

690.14 Additional Provisions (Revised)

Proposal: Revise the 690.14 as shown:

690.14 Additional Provisions. The primary direct current (DC) photovoltaic disconnecting means shall comply with 690.14(A) through 690.14(D).

Substantiation: Clarifies the intent of this section to apply to the primary (main) DC PV disconnect and not to any secondary DC disconnects or AC disconnects that may be installed in the same circuit, such as combiner fuse disconnects or equipment servicing disconnects.

690.31(B) Single-Conductor Cable (Revised)

Proposal: Revise 690.31(B) as shown:

(B) Single-Conductor Cable. Single-conductor cable types SE, UF, USE-2, and single-conductor cable listed and labeled as photovoltaic (PV) cable shall be permitted in exposed outdoor locations for photovoltaic module interconnections in the photovoltaic array. Where exposed to sunlight, Type UF cable shall be identified as sunlight resistant.

Substantiation: Type USE cable was removed from the list of acceptable cables because it does not have the necessary 90°C, wet-rated insulation required in PV module wiring. [USE-2 is acceptable.] A listed and labeled photovoltaic (PV) cable was added and is available for these installations. This cable has a 90°C, wet-rated insulation that is more durable than SE and USE cable insulation, and it has passed the long-duration, 700 hours, accelerated sunlight exposure tests. This PV cable will also meet the requirements for PV cables on the ungrounded PV systems allowed by 690.35.

The revised sentence restricts the use of these exposed cables to module interconnections, and that should prevent them from being used away from the PV array (as some installers are doing). The reference to article 340 is removed because connecting and routing conductors between modules has little relationship to the wiring requirements in 340 II. Long, series-connected strings of PV modules and the listed grounding points preclude routing all conductors of a circuit together inside the PV array as required in 340 II. Away from the PV array, all conductors will be grouped together in a normal NEC Chapter 3 wiring system.

690.31(C) Flexible Cords and Cables (Revised)

Proposal: Add the following second paragraph to 690.31(C):

Flexible, fine-stranded cables (finer than Class C stranding) shall only be used with connectors and terminals (individually or on devices) that are specifically listed and marked or otherwise identified for use with such cables.

Substantiation: UL Standard 486 A&B requires that connectors and terminals that are intended for use with

flexible, fine-stranded cables be so marked for use with such cables. Very few connectors and terminals have been listed for such use and are so marked. The vast majority of connectors and terminals are unsuitable for use with fine-stranded, flexible cables. However, the limited distribution and wording of the standard has resulted in these unmarked connectors being used improperly with flexible, fine-stranded cables. Failures in several widely different industries have been reported.

690.31(F) Fine-Stranded Cables (New)

Proposal: Add the new section 690.31(F) as follows:

690.31(F) Fine-Stranded Cables. Flexible, fine-stranded cables shall only be used with terminals and connectors that are listed and marked for such use.

Substantiation: See the substantiation for 690.31(C) above.

Code Help

As a *Home Power* reader, your assistance is requested for helping the PV industry formulate the 2008 NEC. Grab a copy of the *2005 NEC Handbook* (which explains the code in detail) to see where we are, and then send me your comments and suggestions. You may also submit proposals directly to the NFPA; see the procedure and form in the back of the code. However, substantiations must be strong and technically verifiable.

The 2005 version of my *Photovoltaic Power Systems and the National Electrical Code: Suggested Practices* manual is now available. You may download a color copy from the SWTDI Web site, or you may order a black and white printed copy from Connie Brooks at cjbrook@sandia.gov.

Correction

In the *Code Corner* in *HP102*, the reference to “thread-forming” screws used for module grounding should be changed to “thread-cutting” screws.

Access

John C. Wiles, Southwest Technology Development Institute (SWTDI), New Mexico State University, Box 30,001/ MSC 3 SOLAR, Las Cruces, NM 88003 • 505-646-6105 • Fax: 505-646-3841 • jwiles@nmsu.edu • www.nmsu.edu/~tdi

2008 NEC Proposals PDF • www.nmsu.edu/~tdi/pdf-resources/2008NECproposals2.pdf

Sponsor: Sandia National Laboratories, Ward Bower, Dept. 6218, MS 0753, Albuquerque, NM 87185 • 505-844-5206 • Fax: 505-844-6541 • wibower@sandia.gov • www.sandia.gov/pv

The 2005 NEC & the *NEC Handbook* are available from the NFPA, 11 Tracy Dr., Avon, MA 02322 • 800-344-3555 or 508-895-8300 • Fax: 800-593-6372 or 508-895-8301 • custserv@nfpa.org • www.nfpa.org



North American Board of
NABCEP
Certified Energy Practitioners

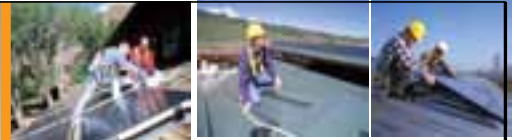

NABCEP Solar PV Installer Certification



Why PV Installers Should Get Certified

- Certification based on industry standards of safety
- Distinguishes you among your peers
- More consumers look for certification as a sign of competence and quality
- Helps you keep current in technology and continue your professional development

Consumer Benefits of Using NABCEP-Certified PV Installers

- Provides confidence that PV system will be installed to manufacturer's specs and in compliance with NEC
- NABCEP Code of Ethics stresses consumer protection, professional conduct and integrity of service
- The installer has met established PV standards and industry requirements through certification process, and keeps current through continuing education

For more information to www.nabcep.org

WE'LL GO THE EXTRA MILE

... to earn your business.

Our success depends on yours, and you can rely on SunWize to support the growth of your solar business. That's why we offer prepackaged systems, same day shipping, three fully stocked warehouses, a dedicated customer service team and technical support. Chris La Forge of Great Northern Solar states, "I like working with SunWize because if there's a problem it's fixed immediately – faster than when I work with other distributors." Call us at 800.817.6527 and find out how SunWize can help your business. Be successful, choose SunWize!

www.sunwize.com



SunWize[®]

Reliable People . . . Reliable Products . . . Reliable Power!

Beautifully Crafted Yurts Designed to be the best.



- Outstanding wind and snow load
- State-of-the-art materials and technology
- Hand-crafted quality

www.RainierYurts.com

Since 1896

866.839.8787



YURTS

Pulse Genetech

www.pulsegenetech.co.jp

CONDITION and PREVENT PREMATURE FAILURE of your battery with NANOPULSER, Electronic Desulfator Device



Ask your fine local dealers for availability, or contact us at info@pulsegenetech.co.jp
Pulse Genetech U.S.A., Inc.
Phone: 425-454-2520

FEATURES

- Inhibits the buildup of hard sulfates, the main cause of capacity loss and failure of lead-acid batteries.
- Regenerates sulfated batteries by desulfating slowly and gently without damaging electrode plates.
- Improves WET, GEL and AGM batteries.
- * Effect can be seen in longer operation hours and easier acceptance of charges. (Specific gravity improves within a few days or weeks depending on the condition and capacity of the batteries.)
- It revives old sulfated batteries, however installing to new batteries is recommended for the best result.

INCREASE YOUR SOLAR OUTPUT

With Solar Boost™ Maximum Power Point Tracking (MPPT) charge regulators Patented technology extracts more power from the PV array – up to 30% more! Reasonably priced and Quality built. Available in a variety of sizes.

We can help with your installation projects.

Solar Boost regulators can charge 12V batteries from a 24V array or 24V batteries from a 48V array. Other configurations available.

Blue Sky Energy, Inc. manufactures and distributes worldwide. Reasonably priced and quality built since 1993.



SB3024I SHOWN WITH OPTIONAL PRO-REMOTE DISPLAY

Contact us today for more information
800-493-7877 or 760-597-1642
2598 Fortune Way, Suite K
Vista, CA 92081 USA
blueskyenergyinc.com

Blue Sky
ENERGY



ELECTRIC TRACTOR - ATV

Clean Quiet Powerful

GORILLA Tough
Made in the USA

WARNING: Not a toy!



CELEBRATING 5 years of satisfied customers.

See our new webpage about **SOLAR CHARGING GORILLAs** and other Electric Vehicles





- Electric Power and Torque
- Almost **Zero** Maintenance
- No Oil, Gas, or Fumes
- 110v Charging or DC Direct
- Silent Utility and Mobility

Mountbarnham in Northern California

info@GorillaVehicles.com
PLEASE SEE OUR WEBSITE
or call for a brochure package

Gorilla Vehicles
a division of Doran Motor Company, Inc.
16121 Saint Croix Circle
Huntington Beach, CA 92649
(714) 377-7776

www.GorillaVehicles.com



Digital Power Meters

Things that Work!
Model 4-1850
Home Power #67

20-CTR: Measures AC Power up to 10 kW, 100-250 vac single or two phase. Remote display. Easy to install.

ONEMeter: NEW FEATURES! Standard Features include Multiple AC or DC power channels (any voltage/current), PC interface (with PC software), internal logging, and one display. Options now include Flash Memory Logging (up to 1 Gig!), USB connection, simple Web interface, extra displays (many types/sizes), Battery Monitor, Weather Monitoring (wind speed, direction, temperature, humidity, solar output) and Control output. The OneMeter can be field upgraded with new hardware/firmware.

4-1850WX: Special meter for Refrigerator Replacement Programs. Detects Defrost Cycle, displays cost/kWh-hrs/yr.

Other Models available. Check our website or call for details.

All products are California CEC eligible meters

CUSTOM APPLICATIONS and DISPLAY OPTIONS: We can build a digital power meter to meet your needs, including large displays as well as the popular Beta Brite scrolling LED sign. Please call with your needs/ideas.

Brand Electronics
421 Hilton Rd.
Whitefield, ME 04353
For information only, call 207-549-3401
info@brandelectronics.com

To order, call toll free
1-888-433-6600
www.brandelectronics.com

ADVANTAGE SOLAR

The New Standard In Renewable Energy Product Distribution.

Whether you're an established dealer, installer, or someone who is interested in entering the solar field, Advantage Solar can provide you with the tools to make your business a success ! Our many years of experience coupled with the latest in business to business technology allows us to offer you service that's unmatched in the industry.



You Know The Name !
You Know The Quality !
Now Experience The Performance Of Mitsubishi Electric Solar Modules !

What's The Advantage ?

- One of the largest renewable energy product inventories in the nation !
- Comprehensive stock of balance of system components !
- Aggressive dealer pricing structure !
- Experienced technical and engineering staff !
- Drop shipments from our warehouse to your customer with your name on the label !
- Professional design assistance !
- Assistance in website creation and hosting !
- Complete system packages !
- Personal, friendly service !



Changes for the Better



Smart choice for power



Advantage Solar Inc. Toll Free 1-877-807-6527 www.advantagesolar.com

Sharing Your Energy

Don Loweburg

©2005 Don Loweburg

We often think of energy in technical terms—volts, amps, kilowatt-hours, and so forth. Yet most people appreciate another kind of energy too. Call it human spirit, vision, calling, mission, or “that which animates human expression.” This is the energy that is fundamentally celebrated and expressed at Whole Earth Festival (WEF), a community-driven event to raise ecological and social awareness through education, music, and art. This festival has taken place every Mother’s Day weekend since 1969 on the University of California–Davis campus.

Besides being free, WEF is special in several ways. First, it is organized and run by student volunteers at UC–Davis. This is no small task, given that this year’s event had more than 300 booths offering food, information, and handmade arts and crafts. Add several performance stages (music, dance, and spoken word), numerous lectures and presentations on everything from social justice to straw bale homes, and more than 30,000 attendees during the three-day event, and you have one great party!

For a fair of this size, WEF is also unique in its zero-waste policy. This year, the compost and recycling campaign diverted 96 percent of all festival “waste” from the landfill. This was partially facilitated by establishing a rental service that provided reusable dishware for attendee use and by prohibiting the use of disposable plates, cups, and utensils by food vendors. Users reclaimed their deposits when they returned the dinnerware to conveniently located wash stations. As a value-added bonus, dishwashing was provided as part of the rental.

And last but certainly not least, WEF taps into solar energy to meet about half of the festival’s electricity needs. More than 20 kilowatts (KW) of grid-tied and off-grid solar-electric (photovoltaic; PV) systems power the performance stages and the WEF staff command post (dubbed the “Karma Dome”). Many vendors and educational booths also brought their own solar-electric power. Offline used their “power wagon” (a trailer-mounted, 5 KW stand-alone system) to meet their energy needs and to power the Karma Dome and a neighboring booth. Sierra Solar Systems provided PV power for the Experiential Space (a lecture space) and the W Stage (host to a variety of music).

Solar on Stage

When WEF started in 1969, solar-electric power was in its infancy. It was not until 1981 when Jon Hill, owner of Sierra Solar Systems, first used solar electricity to power a

small electric keyboard. Though the square wave inverter, which converted the solar-produced DC electricity to AC electricity, produced a considerable buzz, the excitement of running sound equipment on solar energy led to the solar main stage (aka the Quad) becoming a regular presence at all subsequent WEFs.

Early solar-electric setups all relied on batteries to store energy. As the system powering the Quad stage grew year after year, so did its battery bank. At its biggest, the battery bank tipped the scales at more than 5,000 pounds (2,268 kg), and required a forklift to move it. At the WEF 1998, while the batteries were being transported, soft ground gave way under the bank’s weight and the forklift got stuck.

This incident resulted in the brilliant decision to go grid-tied, eliminating the need for batteries at the Quad. And it also simplified and streamlined the setup of the Quad’s solar-electric system, which typically exceeds 10 KW. At the same time, main stage power also got a boost with the introduction of a true sine wave inverter, which got rid of the audible hum in the audio.

The Quad’s grid-tied system is put up and taken down for each festival. Various companies loan PV panels and equipment each year, and the labor of setting up and overseeing the system is contracted. For several years, Sierra Solar Systems sponsored the solar stage. More recently, WEF started putting the solar stage project out for bid. Last year, Cooperative Community Energy, a membership co-op that helps its members install solar-electric systems, won the solar power contract. This year, Quantum Energy Group, a

More than 10 KW of PV for powering the main stage were put up and into service in less than 3 hours.





SMA America loaned the inverters to power this year's main stage.

solar-electric system installer, provided PV power. Other equipment providers have included Trace Engineering (now Xantrex), Sacramento Municipal Utility District (SMUD), and DC Power Systems. SMA America loaned this year's inverters, while Renewable Venture LLC loaned the PV modules.

One, Under the Sun

While an important part of the WEF, solar energy is just one facet of an event that helps demonstrate what our future could look like. It also serves to remind us that the "true power for global change—whether it be social, cultural, or economic—starts with you and your peers, your friends and family, and the folks you have not met yet." You can be a catalyst for change in your community too. So share your good energy, whether it's one compact fluorescent lightbulb, one PV panel, or one renewable energy festival at a time.

Access

Don Lowebug, IPP, PO Box 231, North Fork, CA 93643 • 559-877-7080 • i2p@aol.com • www.i2p.org

Cooperative Community Energy, CCenergy–Marin County, 534 Fourth St., Ste. C, San Rafael, CA 94901 • 877-228-8700 or 415-457-0215 • Fax: 415-457-0216 • info@ccenergy.com • www.ccenergy.com

DC Power Systems, 30C Mill St., Healdsburg, CA 95448 • 707-433-5824 • Fax: 707-433-5698 • daniel@dcpower-systems.com • www.dcpower-systems.com

Quantum Energy Group, PO Box 158, Applegate, CA 95703 • 530-878-4585 • Fax: 530-878-6685 • info@quantumenergygroup.com • www.quantumenergygroup.com

Renewable Ventures LLC, 1 Front St., 33rd Fl., San Francisco, CA 94111 • 415-986-8038 • info@renewableventures.com • www.renewableventures.com

Sierra Solar Systems, 563C Idaho Maryland Rd., Grass Valley, CA 95945 • 888-667-6527 or 530-273-6754 • Fax: 530-273-1760 • solarjon@sierrasolar.com • www.sierrasolar.com

SMA America Inc., 12438 Loma Rica Dr., Grass Valley, CA 95945 • 530-273-4895 • Fax: 530-274-7271 • info@sma-america.com • www.sma-america.com

Whole Earth Festival, University of California–Davis, 260 S. Silo, Davis, CA 95616 • 530-752-2569 • Fax: 530-752-1191 • <http://wef.ucdavis.edu>

Xantrex Technology Inc., 5916 195th St. NE, Arlington, WA 98222 • 800-670-0707 or 360-435-8826 • Fax: 360-435-3547 • info@xantrex.com • www.xantrex.com



INTRODUCING The Guy-less Tilt-Down Tower!

- ✦ Available for turbine rotor diameters up to fifteen feet
- ✦ Safely operated by one person with ease
- ✦ Minimal footprint required
- ✦ Successfully field-tested in Montana for over five years

Provided as complete installation kit

Engineering analysis available

Galvanizing available for coastal locations

Hybrid version consolidates wind and solar power generation

Hybrid Tower

For further information including pricing and specifications: www.solarwindmontana.com

Sun Frost

Energy Efficient
Refrigerators & Freezers

Customized To Fit Your Needs



- ▶ Available in DC or AC
- ▶ Select From Over 10 Models
- ▶ Choose from 1000's of Colors, Finishes & Woods

Providing an Effective Alternative for Energy Conscious Consumers.
Now Making Stylish Home Composting Systems Too!

Please Contact Us For More Info

P.O. Box 1101, Arcata, CA 95518
tel: (707)822-9095 ■ fax: (707)822-6213
info@sunfrost.com ■ www.sunfrost.com

Cut Your Own Lumber!

**Fast!
Easy!
Portable!
Profitable!**

**Call for a
FREE
Brochure
and
Video!**



**See it in action
on our website!**

The Ultimate Portable Saw Mill

**Logs To Lumber -
On The Spot!**

© 2005 Bailey's Inc.

Bailey's
Est. 1975

The World's Largest Mail Order
Woodman Supplies Company -
Selling at Discounted Prices.

Call today and
mention source code:
H7Q5
for your **FREE 2005**
Master Catalog,
Video and Brochure!



TOLL FREE 1-800-322-4539 TOLL FREE
www.baileys-online.com

**Solar Parts and
Systems for the
Do-it-yourselfer**

Serving North America for 25 years

Online Catalog and Design Guide
www.aaasolar.com

AAA Solar Supply
(800) 245-0311
Albuquerque, NM

Searching for a Canadian renewable energy company?

ENERGY ALTERNATIVES has provided thousands of reliable, long lasting and expandable power systems in some of the most remote areas of Canada during our **21 YEARS OF OPERATION.**



Choose from our **DIY packaged systems** or **turn-key professional installation.**

DEALERS WANTED Energy Alternatives offers a comprehensive dealer training program, fast delivery, excellent pricing and superior technical support.



BC Electrical contractor
86683



FREE
Buyers Guide
(for Canadian
customers)

www.EnergyAlternatives.ca

TOLL FREE (800)265-8898

Protecting Our Environment

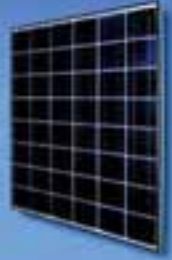

Serving Customers Around the World Since 1979

Solar electrical systems for utility tie applications, remote home, water pumping, and telecommunication systems.

www.solar-electric.com

(800) 383-0195 • (928) 526-8017

2725 East Lakin Drive, Flagstaff, AZ 86004

fax (928) 527-0729 • windsun@wind-sun.com

Log-on to your future @ www.solarenergy.org

Renewable Energy Online Education

Photovoltaic Design Online Course

Sep 6 – Oct 14 • Oct 31 – Dec 9

Solar Home Design Online Course

Sep 6 – Oct 14

"The course was exactly what I had hoped for. It covered all of the key areas and built on them in each successive chapter. Well planned and increasing challenging. Well worth the cost and I am looking forward to applying the knowledge to my own design. The contacts and links were exceptional and will be used over and over again."

-- Spring 2003 Course Participant

Online alums get tuition discounts to future hands-on workshops!

Start your renewable energy education from home...TODAY!

Solar Energy International

www.solarenergy.org • sei@solarenergy.org • 970-963-8855

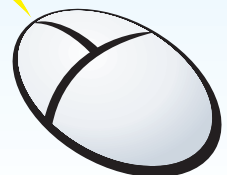

Now Is the Time

Working from Both Ends

Michael Welch

©2005 Michael Welch

President Bush has asked Congress to have a national energy bill on his desk, ready for signature by the beginning of August. Right now, that looks like an impossible task. The Senate's version of the bill has not been released, and after its release, it will need to be passed and reconciled with the House version, which was passed in April.

This may be the last opportunity for *Power Politics* readers to have an effect on this bill, unless it gets held over for longer than expected. In my last column, I asked readers to contact their congressional representatives about the energy budget. The energy bill is just as important. The top-down strategy of letting your representatives know how you feel about both will help make our need for a renewable energy future a little more apparent to them. The energy bill sets the direction for the Department of Energy (DOE), and the energy portion of the federal budget allocates the DOE's funding. Both are important components, but if funding is not allocated for a particular item, the DOE won't be able to move forward on it.

Get It Right, Now!

Redwood Alliance, where I volunteer, is an associate of the Sustainable Energy Coalition, a coalition of nonprofits and companies committed to a sustainable energy future. We received a succinct yet comprehensive wish list from them about the energy bill (see the sidebar), beginning with a poignant warning:

Failure to pursue and enact energy legislation that embraces these principles will only assure a worsening of the energy problems now facing the United States, delay the transition to a sustainable energy economy, and ensure that Congress will have to continue to revisit this issue over and over again in the future until it gets it right.

Take a look at the coalition's energy bill wish list, and then call your senators and your representative. Explain that you do not want any more tax money to go to nonrenewable energy projects, and that you want them to support a sustainable federal energy policy.

National & Local Action

It is equally effective to actively seek change in energy policy through grassroots efforts, a "bottom-up" strategy. Considering how unresponsive our federal government is to citizen concerns, it may be *more* important. More and

more community organizers and even local governments are getting involved in trying to influence national policy.

I work and play in Arcata, California. This community regularly makes the regional news because it elects council members who speak out about and participate in issues of national significance. The Arcata City Council has been a participatory, active council since the early 1980s, when voters first showed them what they wanted by overwhelmingly passing a law calling for the permanent shutdown of the Humboldt Bay nuke plant, and calling for the use of renewable energy instead.

Recently the council formed an energy committee to help guide the city and the community into a more sustainable energy lifestyle. City and energy committee projects have included installing a 10 KW solar-electric (photovoltaic; PV) system on city hall, a retrofitting of city hall and the wastewater treatment facility with energy efficient appliances and pumps, purchasing neighborhood electric vehicles (NEVs) and hybrid gas-electric cars for city employee use, and putting on a huge workshop on how to finance a rooftop PV system.

Don't Question This Authority

One of the things that came out of the Arcata city council, their energy committee, and other local energy committees' efforts is the startup of the quasi-governmental Redwood Coast Energy Authority (RCEA). This new organization is doing a lot of good in the community. Its board is made up of representatives of several local governments, and as an organization, it has been able to do things that other energy nonprofits have not. For example, having a budget from the cities and county has allowed it to dedicate significant staffing and resources to applying for state and federal grants. Government agencies seem to love giving grants to other agencies, much more so than local nonprofits, and this new organization is taking advantage.

In just the last year, RCEA has started some great projects, including community workshops on energy efficiency and rooftop solar energy, workshops for contractors and developers to prepare them for renewable energy (RE) home building, and workshops for educators to start kids moving toward RE. Even the local community college is looking at incorporating solar thermal and PV systems into its industrial technology program, starting an RE program for high school students, and even thinking forward to training

Sustainable Energy Coalition's Wish List

The Senate should seize this once-in-a-decade opportunity and craft an energy bill to accomplish three primary goals:

- Substantially reducing the level of energy imports
- Slashing the emission of greenhouse gases
- Making the transition from polluting energy sources like nuclear power and fossil fuels, which threaten national security and the environment, towards domestically available renewable energy resources, energy efficient technologies, and a sustainable hydrogen economy

To realize those goals, national energy legislation should incorporate strong renewable energy and energy efficiency provisions including the following:

- A national renewable portfolio standard (20% by 2020)
- A national renewable fuels standard (20% by 2020)
- A long-term (5+ years) production tax credit that benefits the cross-section of commercially available and emerging renewable energy technologies, and provides comparable financial incentives for tax-exempt entities such as municipal utilities
- A package of renewable energy investment tax credits benefiting the mix of domestically available renewable energy technologies
- National standards for net metering and interconnection, to facilitate the development of distributed renewable energy technologies, and enhanced transmission and distribution grid reliability
- Budget authority for federal agencies to aggressively increase their purchase of electricity generated from domestically available renewable energy sources
- Authorization levels for federal renewable energy and energy efficiency program budgets that are at least twice as high as current levels

- Fuel efficiency standards for automobiles and trucks to be improved by no less than 50 percent over the next decade and doubled within two decades
- Substantially improved efficiency standards for lighting, appliances, utilities, and industrial motors
- Tax incentives to promote efficiency improvements in new and existing buildings, and to encourage the purchase of energy efficient appliances, automobiles, and heavy-duty vehicles
- Permanent authority for federal agencies to enter into energy service performance contracts without restrictions of any kind, to facilitate efficiency upgrades in government buildings
- Provisions for reducing the levels of greenhouse gas (GHG) emissions, including—but not limited to—a cap-and-trade system, enhanced incentives for voluntary programs, formal designation of carbon dioxide (CO₂) as a pollutant subject to EPA regulation, and expanded funding for research and implementation of GHG control technologies.

National energy legislation should not include new federal expenditures, tax subsidies, or policy initiatives designed to facilitate:

- Construction of new nuclear power plants
- Drilling in the Arctic National Wildlife Refuge
- Siting and building of liquefied natural gas facilities, particularly in communities opposing them, which will facilitate greater dependence on energy imports
- Drilling for, or mining of, fossil fuels in environmentally sensitive areas
- Rollbacks of existing environmental and consumer protections

PV installers—all as a result of RCEA's involvement in the community. RCEA brought together an advisory committee made up of most of the local folks involved in RE education, advocacy, and the trades, to put together a plan for a "thousand solar roofs" in our community.

This is a grassroots effort, and now it is spreading slowly outward and upward. Citizen action and interest has created community advocates, who in turn have created more interest and action on the local level. This movement is growing, and is starting to encompass our county. Other communities are seeing similar results.

The efforts are continuing up the political ladder, slowly spreading. California's Million Solar Roofs bills (SB 1 &

SB 1017) are being debated in its capitol as this is being written, and has support from both major political parties—all because of the success of the state's rebate program, and the advocates and communities that supported those early RE rebates.

Work from Both Ends

It's clear that we have to work for RE from both ends of the spectrum—federal energy and spending legislation, as well as the local level. Keeping the pressure on the feds and seeing little movement demonstrates that grassroots organizers and active community governments like Arcata need to grow and influence the national scene from the

bottom up. The snail's pace of bottom-up efforts points out the far-reaching results of mere pen strokes on the federal level, whether positive or negative.

Write your congressional representatives today about national energy policy, and tomorrow start helping the grassroots efforts in your community to learn about and move toward a sustainable energy future.

Access

Michael Welch, c/o Redwood Alliance, PO Box 293, Arcata, CA 95518 • 707-822-7884 • michael.welch@homepower.com • www.redwoodalliance.org

Arcata City Hall, 736 F St., Arcata, CA 95521 • 707-822-5951 • citymgr@arcatacityhall.org • www.arcatacityhall.org

Redwood Coast Energy Authority, 517 5th St., Eureka, CA 95501 • 800-931-7232 or 707-269-1700 • Fax: 707-269-1777 • info@redwoodenergy.org • www.redwoodenergy.org

Sustainable Energy Coalition, 1612 K St. NW, Ste. 202-A, Washington, DC 20006 • 202-293-2898 ext. 201 • Fax: 202-293-5857 • kbosson614@yahoo.com • www.sustainableenergy.org

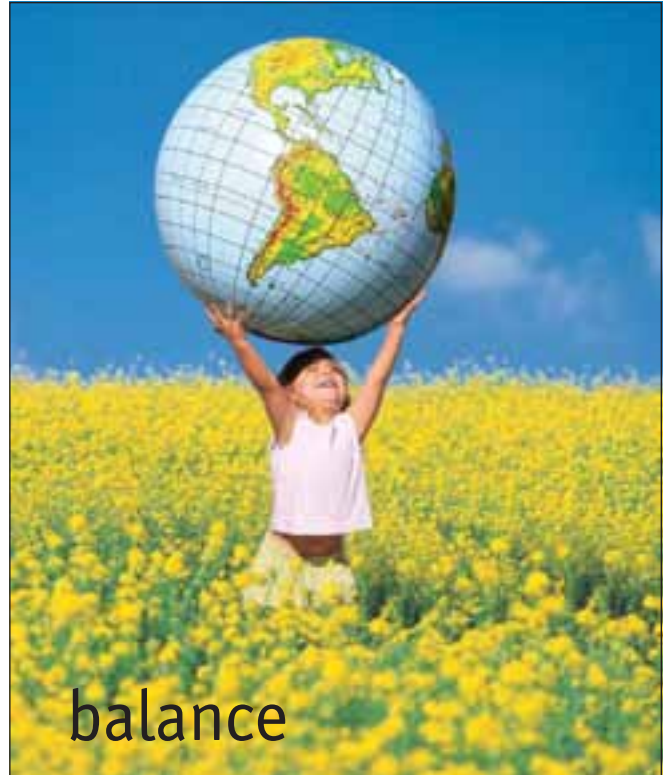

balance

6th Annual



Rocky Mountain Sustainable Living Fair

Powered by Nature

Sept. 17 & 18, 2005

Fort Collins, Colorado
At the New Belgium Brewing Back Forty

Renewable Energy | Sustainable Living Practices
Environmental & Social Responsibility
Green Building | Natural Health | Alternative Vehicles
125 Vendors | Keynote Speakers | 25 Workshops



For Exhibit & Sponsorship info: SustainableLivingFair.org 970-224-FAIR



NORTHWEST
Renewable Energy FESTIVAL

Plug in TO THE future

Sept. 23 - 25, 2005
Walla Walla County Fairgrounds
9th and Orchard
Walla Walla, Washington

Free Admission!

Highlights

- Electric car races
- Solar, wind and wine tours
- Children's activities in the Kid Zone
- Exciting speakers, workshops, and exhibitors

(509) 337-6200 • info@nwrefest.org
www.nwrefest.org

IT'S MORE THAN THE ULTIMATE IN GREEN TECHNOLOGY . . .



it's off-the-grid fun!

AMY GOODMAN **DERRICK JENSEN** **MIKE RUPPERT** **HUNTER LOVINS**
DEMOCRACY NOW! WELCOME TO THE MACHINE CROSSING THE RUBICON NATURAL CAPITALISM

DAVID LINDLEY **HOLLY NEAR**

SOLAR • WIND • WATER
GREEN BUILDING
RENEWABLE ENERGY
PERMACULTURE

aug 20 & 21

HOPLAND CALIFORNIA



TEN YEARS OF POWERFUL IDEAS

GREEN MARKETPLACE

INSPIRING WORKSHOPS

PROGRESSIVE SPEAKERS

LIVE MUSIC & DANCE

DELICIOUS HEALTHY FOOD

ORGANIC BEER & WINE

FUN KIDS' ACTIVITIES

SOLAR MERRY-GO-ROUND

www.solfest.org 707 744 2017



DC POWER • DEMOCRACY NOW! • FREY VINEYARDS • HARMONY FARM SUPPLY • NEW LEAF PAPER
OUTBACK POWER SYSTEMS • RASTRA • SUNWIZE • THANKSGIVING COFFEE • UKIAH BREWING CO. • WOLAVER'S



PENNSYLVANIA
renewable energy
& sustainable living
FESTIVAL
September 23-24 2005
Located in Beautiful Kempton, PA



FAIR FEATURES:

Exhibitors, Workshops and
Speakers on Solar, Wind,
Hydro, Hydrogen, Green
Building and Biofuel Vehicles.

www.PAenergyfest.com

Organic Farming • Music • Green Political Awareness:
A True Celebration of Earth-Friendly Living

"SEE the Future"

Aug 26-28, 2005
WNC Ag Center
Fletcher, NC

5th Annual

Southern Energy
& Environment Expo

Sponsored By
BackHome Magazine



Featuring:

Solar Energy • Wind Power • Hydropower
Forestry • Clean Air • Clean Water
Sustainable Living • Green Economic Development

Presentations & Workshops:

Alternative Building • Clean Air
Solar Electric • Wind Electric
Bio Fuels • Organic Gardening

For More Information Visit

www.seexpo.com

who would have guessed that
insisting on biodegradable
cafeteria utensils would
brand joyce as
the company . . .

subversive?

A JOINT PROJECT OF GLOBAL EXCHANGE & CO-OP AMERICA

greenfestival™

SUSTAINABLE ECONOMY ECOLOGICAL BALANCE SOCIAL JUSTICE

You want to be green, but you have questions.

Can you make a fork from corn? Are solar panels really getting cheaper? Is it fair for my job description to include "clean glass ceiling"?

At Green Festival you'll find real answers, great food, live entertainment and guilt-free compostables.

Live well, do good.

september 24 & 25

washington dc washington convention center

november 5 & 6

sanfrancisco concourse exhibition center

www.greenfestivals.org



DR. BRONNER'S
& SUN DOG'S
MAGIC



THE RENEWABLE ENERGY ROUNDUP
& GREEN LIVING FAIR



Lectures, Exhibits, Demonstrations, Family Activities, Natural Food,
Green Products for Sale, Music

The biggest sustainability event in the South!

Sept. 23-25 Fredericksburg, TX

877-3ROUNDUP email:ROUNDUP@txses.org

www.TheROUNDUP.org

SWITCH ON RENEWABLES

IOWA ENERGY EXPO 2005

WORKSHOPS ON RENEWABLE ENERGY, ENERGY EFFICIENCY, SUSTAINABLE LIVING, GREEN BUILDING, UTILITY ISSUES AND PERSPECTIVES, GLOBAL WARMING, IOWA ENERGY SOURCES & PRODUCTION

EXHIBITORS FROM BUSINESSES,
NON-PROFITS & STATE AGENCIES

ALTERNATIVE FUEL VEHICLES, ELECTRIC
CAR DISPLAYS AND DEMONSTRATIONS

FOOD AND FAMILY ENTERTAINMENT

SILENT AUCTION CHILDREN'S PROGRAM

SATURDAY, SEPTEMBER 10TH 9AM-5PM AND
SUNDAY, SEPTEMBER 11TH 10:30AM-4PM

\$5 INDIVIDUAL, \$10 FAMILY SUGGESTED DONATION

PRAIRIEWOODS FRANCISCAN SPIRITUALITY CENTER
120 E. BOYSON ROAD, HIAWATHA, IOWA 52233



FOR MORE INFORMATION,
CONTACT I-RENEW AT (319) 341-4372
OR WWW.IRENEW.ORG



2005 Oregon Tour of Green and Solar Homes

Tours will take place this fall in Portland, Bend/Redmond,
Eugene, Asland, Corvallis, Cottage Grove, Salem,
John Day, Klamath Falls, LaGrande and Roseburg

For more information on the tour
check out the website:

<http://egov.oregon.gov/ENERGY/RENEW/Solar/Tour/2005/TourHome.shtml>

Be looking for the 2005/6
Green and Solar Building Oregon Magazine
- Due out August 1st!



Phase: Wave Alignment

Ian Woofenden

©2005 Ian Woofenden

Derivation: from Greek phasis, appearance of a star, phase of moon; from Greek phainein, to show, appear.

By definition, alternating current (AC) electricity alternates, or continually reverses its direction. The voltage and amperage peak, go to zero, and peak in the other direction. The pattern this takes is called a waveform, and the ideal is a sine wave—a smooth wave.

“Phase” describes the timing of waves and their relationship to each other. When two waves start, peak, and zero at the same time, we say that they are “in phase.” This describes the condition necessary when a grid-synchronous inverter connects to the utility grid. The sine wave from the inverter must match up with the sine wave from the grid, so they can work together.

The common electricity in your home is called “single-phase,” which means there is a single wave in the home’s circuits, peaking, zeroing, and peaking in the opposite direction. A rotating generator produces this wave. A complete wiring circuit consists of one wire going from the generator to the load, and another returning from the load to the generator.

Single-Phase

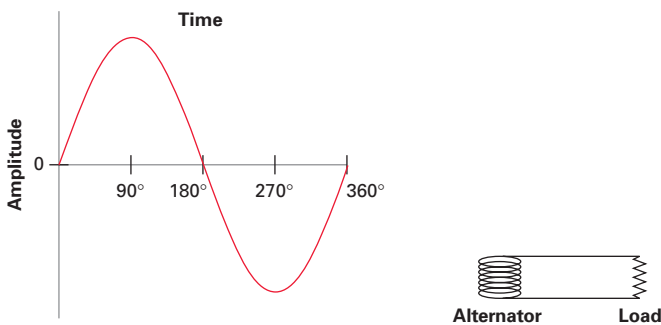

Three-phase electricity consists of three waves. Think of it as three generators sitting side by side, each putting out a single-phase wave. In fact, three-phase generators have three different electrical windings in one generator case, each putting out a separate wave. The three waves are not in phase, but are offset.

One wave starts, and the second wave starts one-third of a cycle (or 120 degrees) later, with the third wave starting another one-third cycle later (240 degrees after the first wave starts). If you look at the sine wave diagram of three-phase output, you’ll see that each wave peaks positive, hits zero, and peaks negative at a different time.

Three-phase circuits can use either three or four wires, and two different, common configurations within each of these options. The diagram below shows the most common wiring arrangement.

Three-phase wiring shares wires between the phases. Because the three phases peak at different times, the output has more power than single-phase of the same magnitude, which has times when both voltage and amperage waves go to zero. Three-phase generators and motors also have more

Three-Phase

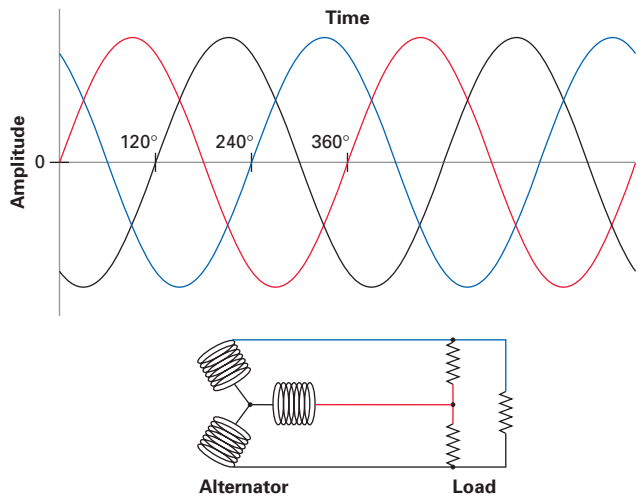

power potential for the same size of equipment (about 150% of single-phase equipment). Three-phase is widely used in industrial applications, and sometimes even in home or farm applications. Although wind and hydro generator output is often three-phase, most of the AC in RE systems is single-phase.

The term “phase” is also used in reference to the relationship between voltage and amperage in AC circuits. In a resistive circuit, voltage and amperage are in phase with each other, and peak positive, go to zero, and peak negative together (though their wave height or “amplitude” may be different). In circuits that are not solely resistive, voltage and amperage can be out of phase with each other. This relationship is called “power factor.” See *Word Power* in *HP99* for a fuller explanation of this concept.

Access

Ian Woofenden, PO Box 1001, Anacortes, WA 98221 •
ian.woofenden@homepower.com



SunDanzzer

Cool with Solar

Energy-Efficient

- Automatic operation
- Thick polyurethane insulation
- Lockable lid
- Interior light
- Corrosion resistant coated steel exterior
- Patented low-frost system
- Easy to clean interior
- Low maintenance



12/24 VDC Energy Efficient Refrigeration

**(866) Sun-Danz
(866) 786-3269**

www.sundanzzer.com

AUTOMAGIC BATTERY WATERING



WE MAKE WATER FROM YOUR GAS

Hydrogen and oxygen battery gas catalytically recombined into pure water and returned to each battery cell. Keeps battery topped off for extended periods of time and reduces maintenance costs. Explosive hydrogen gas is virtually eliminated from the battery area. Corrosive spray and fumes are contained and washed back into each battery cell. Electrolyte kept strong longer, extending the useful power and life of the battery. HYDROCAP Vents simply replace the battery's caps. Battery maintenance is greatly reduced. Write or call for more information.



Things That Work

Hydrocap
GAS-TO-WATER CAPS

305-696-2504
975 NW 95 St.
Miami, FL 33150

You Say You Want a Revolution? We'll Show You How.

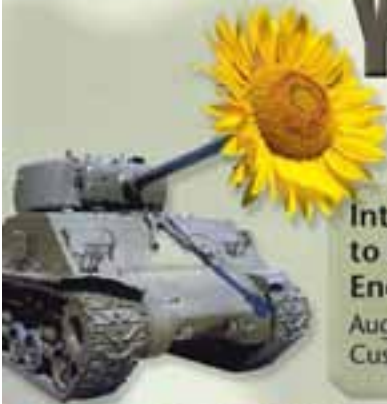

Introduction to Renewable Energy

August 27
Custer, WI

Advanced Photovoltaics Installation

September 13-17
Glenwood, WI

Biodiesel & Vegetable Oil Fuels

September 24
Madison, WI

Solar Space Heating Systems

October 8
Custer, WI



We all want to change the world. Call or click for more information.

Midwest Renewable Energy Association

7558 Deer Road
Custer, WI 54423

phone (715) 592-6595
fax (715) 592-6596

info@the-mrea.org
www.the-mrea.org

Altered States

Kathleen Jarschke-Schultze

©2005 Kathleen Jarschke-Schultze

At the end of my column, I always mention that my home is in northernmost California. This is true—except on Thursdays. Then I live in the 51st state, the State of Jefferson.

State of Defiance

In 1852, a bill was introduced in the California Legislature to create a new state made up of parts of northern California and southern Oregon. The new state was to be called “State of Klamath.” The bill died in committee.

Throughout the years, this idea of forming a new state was visited several times by politicians of both states. The years 1853, 1854, 1856, 1859, 1877, 1878, 1882, 1909, and 1935 had all seen various movements for secession, each with their own map of the proposed new state.

Residents in the counties of northernmost California and southern Oregon have always felt that they have not been well represented by their state governments in Sacramento and Salem, respectively. These areas have had their vast natural resources depleted to fill the needs of the more populated areas. Meanwhile, neither state government has responded to the needs of this region with any knowledge or real concern.

In 1935, Judge John C. Childs of Crescent City in Del Norte County, California, declared himself governor of the good-humored Jefferson Secessionist movement. By bringing attention to the movement and his geographic location, he was somewhat successful in getting the roads along the Redwood Coast improved.

State of Jefferson roadblock on Highway 99, November 1941.

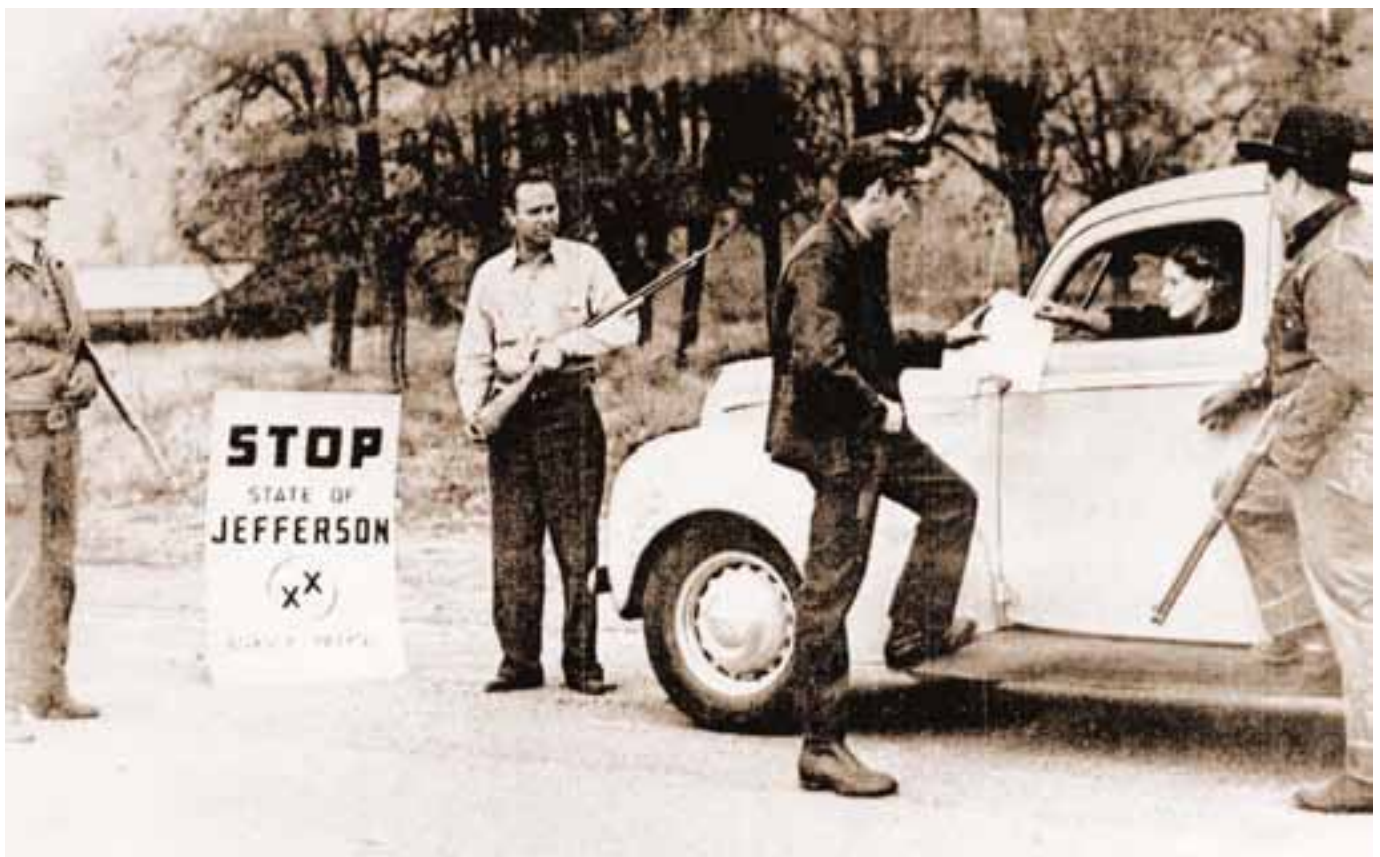

Courtesy Siskiyou County Historical Society

Another man, Gilbert E. Gable, became Mayor of Port Orford, in Curry County, Oregon. He soon heard of the "State of Jefferson," and realized that its "citizens" agreed with his views. On October 2, 1941, his case for a new state was presented before a county judge. The judge approved the proposal and started a study of the procedure for the formation of a new state comprised of Curry, Josephine, and Jackson counties of Oregon; and Del Norte, Siskiyou, and Modoc counties of California.

A meeting was held in Yreka, California, on November 17, 1941, to discuss the development of a six-county alliance to promote the mineral and timber resources in northern California and southern Oregon. People in Yreka embraced this idea.

The next day, the Yreka Chamber of Commerce voted to investigate the formation of this new state. The Chamber of Commerce wanted to name the state "Mittlewestcoastia." But the Yreka newspaper decided to hold a contest to find a different name for the new state. The responses included such names as Orofino, Bonanza, Del Curiskiyou, Siskardelmo, New West, New Hope, Discontent, and Jefferson.

"The State of Jefferson" was the winning entry, as announced several days later. The *San Francisco Examiner* published some of Gable's proposals. The new state would be free of obnoxious taxes—no sales tax, no liquor tax, and no income tax. Gable also considered slot machines unfair competition for the local stud poker industry and wanted them outlawed.

That same week, Yreka was designated the temporary state capitol and the seal of the State of Jefferson was created. The seal is a gold mining pan etched with two Xs. This was to illustrate that the populace had been "double-crossed" by Salem and Sacramento. The movement gained national attention. A young reporter named Stanton Delaplane was dispatched from the *San Francisco Chronicle*. He arrived in Yreka on November 26.

On this same day, the citizen's committee issued their Proclamation of Independence. This was sent to California's Governor Olson. They also set up a roadblock on Highway

Bob-O models his secessionist wardrobe that he wears on Thursdays.



Proclamation of Independence

You are now entering the State of Jefferson, the 49th State of the Union. [Ed. note: Hawaii and Alaska were not yet admitted to statehood.] Jefferson is now in patriotic rebellion against the states of California and Oregon. The State has seceded from California and Oregon this Thursday, November 27, 1941. Patriotic Jeffersonians intend to secede each Thursday until further notice.

For the next hundred miles as you drive along Highway 99, you are traveling parallel to the greatest copper belt in the Far West, seventy-five miles west of here. The United States Government needs this vital mineral. But gross neglect by California and Oregon deprives us of necessary roads to bring out the copper ore.

If you don't believe this, drive down the Klamath River highway and see for yourself. Take your chains, shovel and dynamite. Until California and Oregon build a road into the copper country, Jefferson, as a defense-minded State, will be forced to rebel each Thursday and act as a separate state.

Please carry this proclamation with you and pass them out on your way.

—State of Jefferson Citizens Committee
Temporary State Capitol, Yreka

This 1941 Proclamation handbill was handed out to travelers through the region.

99. Armed with target pistols and deer rifles, they handed out red and blue windshield stickers, which read, "I have visited Jefferson, the 49th state." They also dispensed yellow handbills of their Proclamation.

The Promised Land

The State of Jefferson took a blow on December 2, 1941, when Gilbert Gable died suddenly. Flags were flown at half-mast throughout Jefferson. The *Yreka Daily News* claimed, "Hizzoner was one smart cookie." Ten minutes after being informed of his death, the Siskiyou Board of Supervisors voted to carry on the work he had started.

Mr. Delaplane of the *Chronicle* continued to send articles from Yreka to the newspaper's head office in San Francisco. One caption read, "The Yreka Rebellion: Why Is It Growing?—Our Scout Tries to Reach Grants Pass Highway—He's Still Stuck Halfway!"

On December 4th, an election was held in Yreka and John C. Childs was inaugurated as governor of Jefferson. *Time* and *Life* magazines sent photographers to cover the event. Four Hollywood newsreel companies filmed the ceremony and parade.

The torchlight parade that evening was festooned with signs proclaiming "California forgot us," "Our roads are not passable, hardly jackassable," "If our roads you would travel, bring your own gravel," and "The promised land—our roads are paved with promises." On December 8, 1941, the newsreels were to be released in theaters across the United States.

Under Attack

On December 7th, 1941, Japan attacked Pearl Harbor and brought the United States into World War II. Governor Childs' last official act was to release this statement:

In view of the national emergency, the acting officers of the Provisional Territory of Jefferson here and now discontinue any and all activities. The State of Jefferson was originated for the sole purpose of calling attention of the proper authorities...to the fact that we have immense deposits of strategic and necessary defense minerals and that we need roads to develop them. We have accomplished that purpose and henceforth all of our efforts will be directed toward assisting our States and Federal Government in defense of our country.

—San Francisco Chronicle, December 9, 1941

If at First You Don't Secede...

All was quiet for years, and then in the mid-sixties, the Josephine County Historical Society published *The Mythical State of Jefferson*. The Jefferson State name started showing up in businesses. The local public radio station changed its name to Jefferson Public Radio in 1990. Their magazine *Jefferson Monthly* goes out to members living within their 60,000 square miles of broadcast area in Southern Oregon and Northern California.

Local business entities include the State of Jefferson Radio Amateurs Ham Directory, Jefferson Lock and Key, Jefferson State Plumbing Company, Jefferson State Mortgage, Jefferson State Pest Control, and Jefferson State Sanitation Company. Many, many vehicle license plate holders proudly announce "Resident of the State of Jefferson" in the borderlands of Oregon and California.

Recently, when I was wearing my "State of Jefferson" hat at a garden show in Medford, Oregon, a man stopped me and asked where I had gotten it. "Down in Yreka, the state capital, at the hardware store on Miner Street," I replied. Bob-O and I have also designed and printed T-shirts for ourselves and friends, so we can have complete secessionist wardrobe ensembles.

Secession and the State of Jefferson are now more of an attitude than a serious movement. The basic problems with Salem and Sacramento still exist. But we'll never be able to outvote the population centers of our respective states. It wasn't that long ago that this pioneering country was wild and woolly. That spirit of independence lives on in the hearts of all Jeffersonians.

Access

Kathleen Jarschke-Schultze is busy harvesting from her trees, bees, and garden at her home in the State of Jefferson. c/o *Home Power* magazine, PO Box 520, Ashland, OR 97520 • kathleen.jarschke-schultze@homepower.com



• Simmons •
Natural Bodycare
simmonsnaturals.com
 MAKING
 EVERYDAY
 SPECIAL
 Off the grid since 1982

**The North Carolina Small Wind Initiative
 2005 Workshop Series**

Each workshop will include hands-on activities at the Small Wind Research and Demonstration Site on Beech Mountain, NC. The R&D Site currently features six wind turbines, ranging from 400w to 20,000w.

- Introduction to Wind Power R&D Site Tour
September 10th
- Southwest Windpower Whisper 200 Grid-Tie Installation Workshop
September 17-18th
- Introduction to Wind Power R&D Site Tour
October 15th

Bachelors and Masters Degree Programs also available.

Appalachian www.wind.appstate.edu
wind@appstate.edu (828)262-7333 ENERGY

your complete guide to

COOKING WITH THE SUN

146 Pages
 200 Photos & Diagrams
 Solar Cooker Designs

NOW HALF OFF!
 just \$7.50 (+shipping)

Order online at
www.homepower.com/hf
 or call 800-707-6585
 or 541-512-0201

share what you know!

Write for Home Power

We're always looking for fresh and inspiring new articles to publish. If you've got a renewable energy story to tell or an area of relevant expertise or experience, consider sharing what you know with other *Home Power* readers.

Have an idea? We're all ears.

Before you start writing, drop us an e-mail at submissions@homepower.com describing what you have in mind. Floating your idea up front could save you a lot of time. If it sounds like a good fit for *Home Power*, we'll work with you to define the editorial, photographic, and informational components needed to cover the topic.

Not a Writer? Not a problem.

We have a top-notch editorial staff who love nothing more than to make you sound brilliant. Don't be shy.

For more information, see our complete submissions guidelines on our Web site.

www.homepower.com/writing



**cash in
if you're
plugged in**

Free Shipping! **\$18.95**

Grab this book and learn how to use free energy from the sun and wind to **power your grid-tied home**. Eliminate or reduce your utility bills and become self-sufficient!

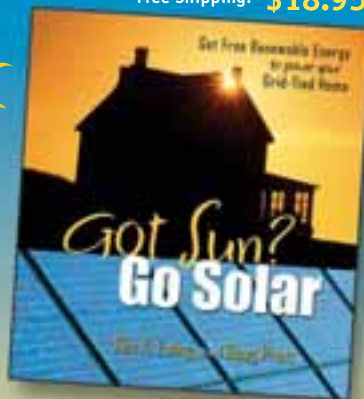

NEW BOOK by Rex Ewing & Doug Pratt. 160-pages with over 120 photos.

Order online, www.pixyjackpress.com | call 303-810-2850
call or write PixyJack Press PO Box 149 Masonville, CO 80541 USA

BZ Products Model MPPT250

250 watt 25 amp Maximum Power Point Solar Control

- Boost charge current up to 30%
- Up to 25 amp output current
- Microprocessor control
- 95 % efficacy
- 250 watt PV input
- 12 to 24 volt input
- Digital metering
- PWM float control
- Battery temperature sensor standard
- 15 amp low voltage disconnect standard
- Aux battery trickle charger standard
- Five year warranty
- Made in U.S.A.



BZ Products, Inc.

314-644-2490 • www.bzproducts.net • bzp@bzproducts.net
7614 Marion Ct., St. Louis, MO 63143, USA

Do You Need Batteries?...

RAE Storage Battery Company

Since 1943... Quality & Service

Surrette Solar 1, 400 Series, Type CH 375 - L16

Engineered under careful guidelines
by Dave Surrette - Family owned
business Est. 1935

Gambissara Solar for export

212-206-6344 • 1201 Broadway,
Room 809, New York, NY 10001

Newly established factory
warehouse. **U.S. Battery Co.**
Corona, CA



Phone 860-828-6007
Fax 860-828-4540
51 Deming Rd., POB 8005,
Berlin, CT 06037

letters to HP

Antique PV

Richard, Can you identify this antique I found still working at a customer's cabin? He gave it to me after I installed his new off-grid system. Thanks, Dick Kent, RV Energy Systems • envirobus@earthlink.net



Hello Dick, Sorry, but I've never seen a PV like that one. The use of half-cells in a module is unusual, and I can only remember one company—Edmund Scientific—that sold this type. As to who made it, I don't know. I did a Web search on the model number and came up with a module being distributed by a company called EIC in Belgium, but no info on who made it. Perhaps some of our readers will have ideas for you. Richard Perez • richard.perez@homepower.com

PV System Cost

I enjoy reading your publication online and find it very enlightening. A couple of articles in HP106 were eyebrow raising. Your cover story, "Off Shore & Off Grid," was a good example of how the current cost of some home solar energy systems is grossly out of reach for mere mortals. Anyone who can pony up more than US\$60,000 for a system—not including labor costs, which were conspicuously absent—must have deep pockets indeed. The inclusion of a US\$12,000, 20 KW propane-fueled generator makes the claim that the home is "powered by solar electricity" disingenuous at best. I also noted that Linda Pinkham's article, "From the Ground Up," was absent any cost figures. Why? Frank Womble • frankwomble@yahoo.com

Hi Frank, The home featured in the article actually had some pretty big loads that were largely powered by solar energy, except when things like the hot tub or the air conditioning were on. When it comes down to it, we would like solar energy to be used by large energy users, as well as average homeowners. In fact, with the huge loads at that island getaway, the amount of carbon that the system is offsetting with solar energy greatly exceeds what I'm offsetting with my system, since my loads are relatively minimal. We can all breathe easier because the McVickers chose to use solar energy to meet some of their needs.

We didn't include a cost table in my article because it wasn't one of our standard system articles, but was focused on the design choices I made. Also absent were technical specifications, a schematic, and installation details, since those are reserved for regular system articles. But my costs aren't a big secret. Gross costs offhand, including the PVs, tracker, inverter, wire, labor, concrete, tool rentals, permits, and engineering, were close to US\$20,000. Of that, Energy Trust of Oregon paid for about US\$9,000, and I received a US\$1,500 state tax credit. So my out-of-pocket cost was about US\$9,500. See "Making Sense of Solar-Electric System Costs" in the next issue, where author and HP marketing director Scott Russell compares various factors and looks at different locations to show how they influence system costs. Take care, Linda Pinkham • linda.pinkham@homepower.com

SDHW Tank Options

Hi Ken and Chuck, I have paid for and downloaded several articles written by you at the Home Power Web site. Thanks for the great information!

I would really like to have a solar domestic hot water (SDHW) system. I don't have a lot of cash and am not interested in financing. Are you aware of any better, low-cost alternatives to the expensive storage tanks specifically designed for SDHW? I was shocked at the prices of these tanks. I am talking about the 120-gallon tanks with four plumbing ports, with or without the heat exchangers. If shipping is included, the cost is almost US\$1,000. As I understand, the life expectancy of a glass-lined tank is just over six years. Suddenly a solar thermal system does not sound so cheap.

I read an article in HP91 by Roy Tonnessen about his homebrew SDHW system. It was encouraging. I especially like the price he paid for the stock tank, listed at US\$66. I see a local company that sells HDPE plastic water tanks. Are these tanks suitable for the temperature of water in a solar thermal system? Thanks in advance for any help you can provide. Dan • d2trab@aol.com

Hi Dan, Three-port electric water heaters are a little less expensive (about US\$800 for a 120-gallon model) than the four-port tanks and can be easily used by adding a "tee" fitting on the drain at the bottom to make a fourth port. One outlet port of the tee is piped to the DHW exchanger pump and the other to the drain. The life expectancy of any glass-lined tank without an internal heat exchanger is more like twenty years plus in my experience.

The warranty is for six years. Galvanized and high temperature plastic tanks are not pressure tanks and are used by many in unpressurized water systems (gravity drain). If you depend on a municipal water system or have any type of pressure system, you need the more expensive pressure tanks to store pressurized hot water.

One suggestion is to investigate using a smaller tank and system if the larger one is a budget buster. There is no economy-of-scale savings in tanks or electric water heaters because of the limited production in the larger sizes. The 120-gallon tanks are almost double the cost of 80-gallon tanks, yet have only a 50 percent larger capacity. All tank prices have gone up dramatically in the last year. Tank manufacturers blame it on new regulations; I say maybe, maybe not. However, I know that one manufacturer increased prices on 40-gallon, three-port tanks by a whopping 25 percent in the last year.

Thanks for your comments about the articles. It's always refreshing to hear from interested readers. Cheers, Chuck Marken • chuck.marken@homepower.com

Passive Solar Design

Hello *Home Power*! Dan Chiras' article on "Sun-Wise Design: Avoiding Passive Solar Design Blunders" in *HP105* was a concise, well-written overview of passive solar basics. I was especially glad that he also addressed the associated cooling issues to avoid overheating. I would like to make a couple of additional comments based on the inquiries we get in relation to our passive solar house plans, which follow the basics that Dan outlines. I believe that his book also covers them in more detail.

Vaulted ceilings: Although the excessively high ceilings that Dan describes will most likely lead to comfort problems, vaulted ceilings should not be completely ruled out. Some change in ceiling height is desirable to create a stack effect, which aids in airflow, especially with cooling strategies. In fact, with roofs framed with trusses, it is preferable to have part of the space framed with scissors or half-vaulted trusses. A window or exhaust fan at the peak allows the hot air to escape or at least rise. With SIP or stick-framed cathedral ceilings (not necessarily high ones), vaulting is unavoidable. Ideally, this space should be converted into living area to give you the most livable square footage for the volume of the house.

Energy analyses and computer software: Although many architects use Energy-10, I do not think that it is user-friendly enough at the current release to be used by homeowners or do-it-yourself designers. I would instead recommend the Sustainable Buildings Industry Council's *Green Building Guidelines* (US\$50 through www.sbicouncil.org) and the user-friendly software, *BuilderGuide for Windows* (BGW2004; US\$99, available through www.solaequis.com). Another valuable tool is *Overhang Design*, a free online program that helps you correctly size overhangs for passive summer shading and winter heating (www.susdesign.com).

We use all of these programs in the design of our passive solar homes. Our new book, *The Sun-Inspired House*,

will have designs that illustrate the various ways that the passive solar concepts discussed in Dan's article can be integrated into a variety of house designs.

Keep up the good work! We emphasize to our clients the complementary ways that the active solar energy systems promoted by *Home Power* can work with our passive solar designs. Debbie Coleman, Sun Plans Inc. • info@sunplans.com

Dielectric Couplings

First I want to thank you for my first copy of *Home Power*. I should have subscribed years ago.

In your article about water heater and solar tank maintenance and anode replacement ("New Life for Your Old Water Heater," *HP106*), I was surprised to see that there was no mention of dielectric couplings.

Three weeks after moving into my newly purchased older house, the hot water tank died the leaky death we all hope to avoid. Not the best of luck, since just six weeks prior, the tank in the previous house also died. I figured I had to get twice the life span out of the new tank just to break even. After reading your article, I will replace my anode rod and go for a three-fold life span! When I installed the second tank, I did some research and found dielectric couplings. I was told by a plumber that these were required by code in Ontario, Canada. It is a simple idea that is cheap (about \$20) and can be installed any time. The coupling screws onto the top of each tank connection, using what looks like nylon flange gaskets to keep the copper pipe from touching the steel tank nipple. If there is no connection between the dissimilar metals, there should be no corrosion. Or at least the corrosion should be drastically reduced. Even in a perfect world, you would still have some free electrons being transferred by the water flow. My tank is now ten years old, and I plan to replace the anode soon. Only twenty years to go. Andreas • adutschke@pacificcoast.net

Hello Andreas, You're right about dielectric couplings. They are not just a good idea—they're essential when connecting copper and steel. We've mentioned dielectric connections in past articles, and will probably cover them more in depth in the future. When a copper fitting is screwed into a steel fitting or vice versa, the two metals will start to react. A joint like this will usually start to leak within a few months. The physical contact of the two dissimilar metals, in addition to the water, causes the rapid deterioration. The dielectric will prevent this joint deterioration and subsequent leakage.

Most dielectrics today come in the form of a union (a two-piece coupling that can be mechanically disassembled) or as corrugated copper water-heater flex (a flexible copper tube about 12 inches; 30 cm long, with a solder connection on one end and a pipe thread dielectric fitting on the other). Brass fittings can also be used as a transition between copper and steel to provide dielectric protection. As you mention, copper and steel do not need to be physically connected to have a cathode-anode relationship. The proximity of the metals and quality of the water both seem to affect how quickly a sacrificial anode is depleted. Thanks for your comments and best to you. Chuck Marken • chuck.marken@homepower.com

Human Power

I am writing in response to Geoff Yokum's letter in *HP106*, about how he can produce about 25 watt-hours in 15 minutes of cranking on a generator attached to an exercise bike. My math tells me that his results are about right; I'd like to add to what he said.

The laws of thermodynamics apply to the human body just as to any other machine. Consider this: A typical caloric intake is supposed to be 2,000 calories per day for women; 2,400 for men. (When looking this up, keep in mind that dietary calories are actually kilocalories—kcal.)

Google.com provides a very useful service in being able to convert units. Entering the query "2,000 kcal in watt-hours" gets the answer "2,000 kcal = 2,324 watt-hours (WH)." Similarly, 2,400 calories gets an answer of 2,789 WH. If you take these and divide by 24 hours in a day, you see that the average power used by the human body is 97 to 116 watts. That's not a whole lot.

Of course, this analysis neglects the fact that our actual moment-to-moment energy consumption varies—less if we sleep, more if we are doing some strenuous activity. The body is fairly efficient at storing up energy excesses (it's where fat comes from, after all) and doling it out at a later time.

Even so, this analysis gives us some food for thought: First, we can put our energy use in perspective. A household that uses 20 KWH of electricity a day (not alarmingly efficient, but not alarmingly gross either) consumes as much energy as almost ten occupants, but usually has far fewer than ten occupants. If you add gas or oil consumed to heat the space and hot water, it only gets more imbalanced. Don't forget to consider the car!

And, speaking of cars, you can develop a true appreciation for a very sophisticated, yet low-tech transportation device—the bicycle. Consider the calories you burn on a 7-mile ride, and compare it to the gasoline burned to go the same distance. Here's a hint: A gallon of gasoline contains 31,000 kcal. Driving 7 miles in a vehicle that gets 30 miles per gallon will burn 7,233 kcal—equivalent energy to three days' food for an average man, almost four days' food for an average woman!

This makes the simple point that a bicycle generator, while interesting and fun, is severely limited. For those who are able to do something interesting with this small amount of energy, more power to you (pun intended)! The effort will give you, as Geoff pointed out, a newfound appreciation for the power of the sun. Best regards, Glenn C. Lasher Jr.

Mixing Different PVs

Dear *Home Power*, I'd like to purchase my first Kyocera KC120-1 panel, but I'm a bit unsure about the process. I finally got up enough guts, but the cheapest I could find was out of stock. The supplier offered me two other panels with different wattages than the KC120. All I want to do is to have a 12-volt array with 12-volt batteries. I'll have to piecemeal this over time, and I'm starting to learn that the same panels may not be available when I need more.

My question is, does it matter if I use solar-electric panels with different rated wattages and probably made by different manufacturers? For instance if I have an 80-watt, 12-volt module, and a 123-watt, 12-volt module, and maybe a 50-watt, 12-volt module, will they all work together in the same array, giving off 253 watts (80 + 123 + 50) at 12 volts, because their output is all 12 volt? Thanks for your help.
John • solar@serverserv.com

Hi John. Three major concerns make mixing modules less than ideal. First, only modules of the same make/model should be series connected. Second, MPPT controllers are less effective when used in conjunction with arrays made up of modules with different operating characteristics. Third, mixed module arrays typically don't look all that great.

Since you're planning to wire your array and battery bank at 12 volts, and will be wiring the modules in parallel rather than series, mismatched modules will work OK. Just make sure that each panel has 36 cells in it, and that your rack system will handle the different physical layouts and sizes of the panels. But keep in mind that if you ever want to increase the array voltage of your system, you'll be stuck, since your varied modules cannot be series connected.

In off-grid systems, MPPT controllers will provide about 15 percent more energy annually, and more during colder months, when days are shorter and users typically need the extra energy. If I were in your shoes, I would definitely consider choosing a standard module make and size. This will give you more flexibility in the future.

Finally, your math above is correct, but keep in mind that module wattage ratings are specified by the manufacturer under ideal conditions. Out in the field, you will see a lower output in hot weather. Michael Welch • michael.welch@homepower.com

Paralleling Batteries

Hello to all the *Home Power* crew. First of all I would like to say that you guys do a wonderful job with this incredible magazine of yours. Since I read my first copy two years ago, I have been hooked—hook, line, and sinker. Your magazine is the first magazine that I enjoyed enough to have become a subscriber! Many others I will buy when I see an interesting article or two, but I never considered subscribing. My wife laughs at me when I impatiently check the mailbox at the beginning of every other month. She has taken to calling me "Solar Frank."

I am an automotive teacher at a local high school and also run the school's environmental club. My students get a little extra dose when we cover renewable energy issues. As a former automotive technician, as well as a General Motors national training instructor, I have a fairly in-depth knowledge of DC systems. We have used terms such as pulse width modulation since the 1980s. Having always dealt with automotive applications however, my knowledge of deep-cycle batteries is weak.

My wife (who is Ottawa's leading straw bale architect) and I purchased 350 acres of property that is off grid. We recently built a small camp that looks a lot like Richard and Karen Perez's "plywood palace." I have installed a 70-watt PV panel with two, 6-volt golf cart batteries and a

1,500-watt inverter. On our property, we have two private lakes that are spring fed. In an effort to maintain and protect the delicate yet vibrant ecosystems, I purchased an electric trolling motor and a deep-cycle, 12-volt battery to use on my small aluminum rowboat.

Now my question: Since I only have the one panel for now, when the battery for the trolling motor is weak, I connect it in parallel with my battery bank to recharge it. Will this shorten the life of the battery bank by causing battery charge inequality? If this is the case, is there a way to prevent this by installing some kind of isolation diode or charge controller?

I look forward to future issues of your magazine. They are a great source of inspiration to me and many others. I have already built an electric trike for my mother-in-law, who is a victim of multiple sclerosis. Its design was inspired by an article in your magazine. It has given her the freedom of "running" that she has not experienced in 25 years. She and I both thank you. Sincerely yours, Frank Dutton, Ottawa, Ontario, Canada • duttonf@magma.ca

Hello Frank, Great work! Thanks for the compliments! You can wire the trolling motor to the main battery in parallel (plus to plus, and minus to minus). This will not shorten the life of either battery if: (1) the voltage in the main system is 13.5 VDC or more, and (2) the trolling battery is disconnected at night (or during cloudy weather) so that it is not discharged with the main system's battery.

Also, make sure that the regulation voltage of the main system is appropriate for the trolling battery. If the main battery bank uses flooded batteries, and the trolling battery is sealed, the regulation voltage will be too high and will damage the trolling battery.

Another option is to parallel the trolling motor battery to the main battery using a blocking diode in the positive lead from the main battery to the trolling battery. (A Schottky-type diode is best, because it has less forward voltage loss.) This option would not require disconnection when the main battery voltage is low or at night. This is called a blocking diode in renewable energy terms, or in RV terms, an isolation diode. This low-cost diode can be purchased from most RE or RV dealers. Also, make sure that the regulation voltage of the main system is appropriate for the

Amish families in the Midwest are turning to PV systems to keep their lives simple.



trolling battery. If the main battery bank uses flooded batteries, and the trolling battery is sealed, the regulation voltage will be too high and will damage the trolling battery. Richard Perez • richard.perez@homepower.com

Amish RE

Hi! I just thought you might be interested in knowing about an interesting movement happening among the northern Indiana Amish communities in Elkhart, LaGrange, and Noble counties. The population of Amish in this area is, I think, the second largest in the nation. The Amish communities choose to be "separate from the world." That means that they choose a "plain life"—plain dress, no electricity, no telephone, no car, etc.

Some of the Amish in our community are a little more progressive and have gradually allowed some forms of technology into their communities. Some Amish businessmen carry cell phones strictly for business use, and turn them off after 5 PM or when they close business for the day. And now we see more "Amish phone booths"—small, enclosed buildings that sit near the road, beside a home's driveway.

The main criteria or questions an average Amish person asks himself and his community about a certain form of technology is, "How will it affect my family and my church community?" and "Will it disrupt in some way our closeness as a community?"

Traditionally in these communities, water was pumped into the home by a large, many-bladed windmill that mechanically moved the pump jack up and down. That has been replaced by gas-powered pumping systems in some areas. Now, that too is changing. Today, some Amish are using solar electricity to pump water, to power their freezers and some lights, and to charge the batteries on their buggies for lighting at night.

In 2003, I worked for an Amish man full time, installing solar-electric systems and driving his company truck to the installation sites (which were almost all Amish). He has a full-time business installing PV, wind, and stationary diesel driveline power units and generators for local homes and businesses. He also repairs inverters on Class A motor homes and other RVs, since Elkhart County is the "RV capital of the world."

The main motivation of the Amish to use solar electricity is, I think, to have some technology, but to remain separate from the utility grid ("the world"). The environmental issue doesn't seem to be the driving factor. Some Amish will install a diesel generator to power other electrical power tools on the farm and to power their pumps. I know of a chicken house that has ventilation fans that are run hydraulically, with the hydraulics run by diesel.

I also saw a curious mix of technology in an Amish home in Shipshewana, Indiana. They use 12 volts to power the lights, but use the 120 VAC diesel alternator to power the sweeper and the washer. I asked my boss why we were going to install both DC and AC in the home, and he said that under their belief system, it was not OK to power the lights with 120 VAC.

These are just a few observations from my experience with PV among the Amish in northern Indiana. Thanks for your time. I really enjoy your publication. Sincerely, Myron D. Yoder • yodermd@juno.com

Tankless Water Heaters

Dear *Home Power*, I enjoyed your article, “Tankless Is In,” in *HP105*. I have tried to recreate the numbers in the table titled, “Typical Water Heater Characteristics,” but have been unable to do so.

Comparing the gas tankless and tank water heaters, and using the annual operating costs of US\$154 and US\$235, and the monthly gas usages of 5 and 24 therms, I get a cost per therm of US\$2.57 for the tankless water heater and US\$0.816 for the tank water heater. If I use the lower rate of US\$0.816 per therm, instead of US\$2.57 per therm, then the monthly energy consumption of the tankless water heater should be approximately 16 therms instead of 5 therms.

Comparing the electric tankless and tank water heaters, and using the annual operating costs of US\$460 and US\$535, and the monthly electric usages of 329 and 436 KWH, I get a cost per KWH of US\$0.117 for the tankless water heater and US\$0.102 for the electric tank water heater. This is a smaller inconsistency than for the gas water heaters, but it is still significant.

We personally have a heat pump water heater (ECR WaterSaver; www.ecrinternational.com/prod_wattersaver_summary.asp), which we are very happy with. It has an energy factor of 2.45. Its rated annual energy use is 1,800 KWH. We have time-of-use electric rates and use a timer so that we do all of our water heating off peak. Our average off-peak electric rate is US\$0.085 per KWH. This results in an annual electric cost of US\$153. For the past year, our average baseline rate for natural gas has been US\$0.94 per therm. Assuming monthly gas use for a tankless water heater is 16 therms, this would result in annual natural gas costs of US\$180—US\$27 more than our heat pump water heater.

Our actual annual electric use for the water heater has been about 750 KWH for two adults. We have a separate kilowatt-hour meter just for the water heater. Our annual electric cost for the water heater is about US\$64. The heat pump water heater replaced a gas tank water heater that used about 12 therms per month, which would have cost us about US\$135 annually at today’s natural gas prices. The very high efficiency of the heat pump water heater more than offsets its standby losses.

My basic conclusion is that gas tankless water heaters and electric heat pump water heaters are both much more efficient and much less expensive to operate than all other types of electric and gas water heaters. Michael Winkler, Arcata, California • mlwinkle@yahoo.com

Diode Direction

The article on PV diodes in *HP107* shows current going the wrong way in the diode. It flows from cathode to anode, negative to positive. John P. Nelson, Nucla, Colorado • jpnnucla@montrose.net

Dear John, Thanks for your letter. The general convention is that current is the flow of holes, meaning positive ions, in a conductor. Holes flow from positive to negative, and therefore from the anode to the cathode in a diode. You can also view current as the flow of electrons, which flow from negative to positive, and therefore from the cathode to the anode in a diode. If you are referring to the flow of electrons, you are right. Mark Byington • markb@cobaltpower.com

Diode Dilemma

Mark Byington and *HP* editors, I wish you or the crew at *HP* hadn’t shown a current of empty holes flowing from positive to negative in the “What is a Diode” sidebar in *HP107*. I’m 25. People my age grew up learning electron theory, not conventional. We’ve all had to learn that true current is going against the diode’s schematic arrow symbol. Since *HP* caters also to electric newbies, I don’t think it’s a good idea to show “conventional” current theory when explaining a part. Newbies don’t know the difference and may use diodes incorrectly.

I think you should have either labeled the current as “conventional” or shown it as “electron theory current.” The fogies and codgers at *HP* and the older readers certainly know the difference, but younger yuppie types are picking up *HP* as well. As always, *HP* rocks otherwise. Mallory Hinkley • gaviidae@lycos.com

Hi Mallory, As my colleague Bill Beaty has pointed out, “since forward-flowing protons give the exact same electric current as backward-flowing electrons, we say that both currents really are exactly the same.”

Like you, I was also taught that current is actually a flow of electrons. In those days, we had to learn all the rules with the opposite hand. It didn’t work. They had to give up teaching that idea. The fiction of positive charge flow was too well established. Nowadays we (conventionally) speak of a current of positive charge, and it’s easier on the brain (so long as you don’t think about electrons). The change didn’t bother me that much, because I actually prefer things simple where possible.

If the world’s education systems failed to turn current around, I doubt if *HP* will succeed. Readers would just end up more confused about electricity, and that would not help anyone. You make a valid point that electrons move in the opposite sense, but this fact has proved to be academic in nature. It makes pragmatic sense to go into that when discussing electrons themselves, and thereafter to forget it. At least that’s my view of the matter. Hugh Piggott • hugh@scoraigwind.co.uk

Environmental Analysis

Howdy *HP* folks. We had a brunch this last weekend and introduced some friends to our off-grid solar-electric system. One guy was a bit of a skeptic regarding the environmental benefits of living off the grid compared to living on a coal-fired grid. While I could explain many benefits such as reducing the influence of corporations and reducing site-specific environmental impacts, I really couldn’t state that the net benefit was positive.

For example, if 1 million people lived off the grid using solar energy in one country and 1 million people lived on

a coal-fired grid in another, which energy system would have the greatest benefit from the standpoint of reducing air and water pollution, and resource consumption? I imagine there are some negative impacts of using lead-acid batteries and solar-electric panels, including hazardous waste produced during the manufacturing process and harm to the environment to extract the necessary raw materials. My gut feeling is that these impacts are much lower than from coal. Do you know if anyone has crunched the numbers? Thanks, John Grim • jga1@gorge.net

Hello John, It's no big secret that coal plants produce pollution. How much pollution they produce can also be quantified fairly easily. But pinning down the exact impact coal-generated electricity has on the environment and human health is more difficult, since there are many ways you can weigh the external factors. For detailed information on coal-fired plant emissions and the consequences, see HP97, October/November 2003.

When comparing solar electricity to coal-fired electricity, a great starting point is to look at the net environmental impact of each source over its operational lifetime. Solar-electric systems are designed to operate for 25 years or more (modules typically have 25-year warranties). In most locations, solar-electric modules will offset the energy it took to manufacture them (embodied energy) in two to four years. After that, energy is generated without using any finite resources, and no pollution is produced. Another way to think about it is that a solar-electric module will produce pollution-free energy for 20 years plus. (For more details, refer to HP80, December 2000/January 2001.) In contrast, a coal-fired plant will always be using finite resources—it will never recoup its embodied energy and, as long as it's operating, it's polluting.

Most solar-electric systems installed today are grid-tied, and do not include batteries. Batteries are used in some grid-tied systems where battery backup is required, and virtually all off-grid systems rely on batteries for energy storage. A high quality battery bank that is well maintained will easily last ten years or more. If we assume a system design life of 25 years, about two sets of batteries will be used over the system's lifetime. Finally, lead-acid batteries are one of the most highly recycled products out there. In the United States, more than 90 percent of these batteries are recycled.

Next time you see your friend, pass this info along. I'm betting that he'll walk away convinced that he'd rather have a solar-electric plant in his backyard than a coal-fired one. Best, Joe Schwartz • joe.schwartz@homepower.com



Courtesy Jules Dervaes (www.pathtofreedom.com)

Oops!

In the "Biodiesel Appleseed" article (HP107), a photo credit should have appeared with the photo printed above. Many thanks for use of the photo and our apologies to Jules Dervaes at www.pathtofreedom.com.



12 VOLT LED LIGHT BULBS



CC Vivid LED Light Bulb

- Energy efficient reading or accent light
- 18 bright white LEDs
- 12 Volt / 2 watts
- 60,000 hr bulb life
- 40 Lumen light output
- \$34.95



CC Vivid + LED Light Bulb

- Energy efficient porch, reading or ambient light
- 36 bright white LEDs
- 12 Volt / 3 watts
- 60,000 hr bulb life
- 90 Lumen light output
- \$44.95

FREE Catalog!
Don't forget to ask about our other LED bulbs!



FREE
US Ground Shipping

C. CRANE COMPANY

800-522-8863 • ccrane.com

KTA SERVICES INC.

Electric Vehicle Components & Systems Since 1984

Components, Conversion Kits, Publications, Videos, & Engineering Design
Services for the EV Hobbyist & Manufacturer

We stock and sell the largest variety of the very best.

Components & Publications Catalog.....\$5.00

944 West 21st Street, Upland, CA 91784 USA

Tel: (909) 949-7914 • FAX: (909) 949-7916 • Web: www.kta-ev.com

SUNELEC.COM

INVERTERS

4000 W and 5500 W Sinewave

Brand New Up to 45% Off!

while supply lasts

TRACE, XANTREX, HEART, OUTBACK

info@sunelec.com

Order Line: 305-536-9917



Solar Meter

The easiest way to obtain accurate irradiance readings.

Pocket-sized • Rugged Dependable • Consistent

Daystar

3240 Majestic Ridge,
Las Cruces, NM 88011
505-522-4943
pvvern@zianet.com
www.raydec.com/daystar

\$134.50
+S&H

A Clean and Quiet Revolution

Enjoy the freedom of driving electric. Join the EAA today and declare your independence from high gas prices and imported oil.



For more information visit us at <http://eaavev.org>

AC Propulsion tzero

ELECTRIC AUTO ASSOCIATION

Get the credit you deserve for caring about the planet at the



Permaculture Credit Union

We are making loans that make a difference to the people who make a difference.

We offer a 0.75% sustainability discount on loans for earth-friendly projects, including:

- Solar heating and electricity systems
- Home energy efficiency upgrades
- Fuel-efficient vehicles
- Efficient windows & insulation
- Rainwater catchment systems

Call us for loan programs and current rates.

(505) 954-3479 or toll-free (866) 954-3479
www.pcuonline.org
4250 Cerrillos Road, P.O. Box 29300
Santa Fe, NM 87592-9300

Do something nice for yourself, your community, and the earth...call the PCU today.



OFF LINE

Independent Energy Systems

Our 21st Year Offgrid!
We provide excellent service & technical support.
Residential Power • Water Systems • Communications
Wind • PV • Hydro • Custom Design • Installation
All Major Brands



Don Loweberg
NABCEP Certified Installer

California Rebates!

OFF LINE

Located in the central Sierra, near Yosemite

e-mail: ofln@aol.com
www.psnw.com/~ofln
P.O. Box 231, North Fork, CA 93643

(559) 877-7080
CA Lic. #661052



SoL

is "Solar-on-Line"
Internet-based Distance Courses with practical skills workshops



Internet-based distance courses year-round
Practical skills workshops offered in the US and Mexico
Visit the Solar-On-Line website for schedule and details

**For current schedule of On-line Courses & Workshops
Click on SoL www.solar-on-line.org**

E-mail: SoL@SoLEnergy.org • Phone/Fax: 720-489-3798
See Happenings in this issue for the 2004 schedule of courses.

All Prices Reduced!

Lower prices on all of our back issues!
 #1-99: \$5.95 ea. • #100-present: \$8.95 ea.
 Complete set (72): \$150 + shipping



Issue 107 Jun/Jul 2005

Zero Energy Home • Cordwood Building
 • Making Biodiesel • Solar Hot Water
 for Beginners • Rainwater Catchment •
 Solar RV • And more!



Issue 106 Apr/May 2005

Island Getaway • Grid-Tie Inverter
 Showcase • PV Design Choices •
 Ram Pump • DIY Solar Fountain • SIP
 Building • And more!



Issue 105 Feb/Mar 2005

Tools of the Trade • Solar Design
 Blunders • Wind Tower Basics •
 Microhydro Intro-Part 3 • Tankless Hot
 Water • Ford Hybrid SUV • And more!



Issue 104 Dec/Jan 2005

Solar in Brooklyn • Solar-Electric Basics
 • Green Building Top 10 • Microhydro
 Intro-Part 2 • Choosing a Fridge • Solar
 Hot Tubbing • Pedal Power • And more!



Issue 103 Oct/Nov 2004

Pete Seeger Picks Solar • Microhydro
 Intro-Part 1 • Adobe Building Primer
 • RE Financing • Masonry Heaters •
 Washing Machine Spin-Off • And more!



Issue 102 Aug/Sep 2004

Solar- and Wind-Powered Green
 Businesses • How-to Load Analysis •
 Wind Basics • Small PV System • MPPT
 Basics • Toyota Prius • And more!

Browse our back issues at www.homepower.com/archive.

Order online or call 800-707-6585 or 541-512-0201



THE STANDARD
 IN PV MOUNTING STRUCTURES™



When it has to look great

Ensure the visual appeal that you and your neighbors demand.



New options and accessories

The most versatile mounting system in the PV industry continues to grow.



Standing-seam solution

The lowest possible installed cost with no rails or penetrations on a standing-seam metal roof.



The large array answer

Low cost, installation ease, and code compliance are our standard.



PV power anywhere

The right rack sized to your needs saves you time and money.

www.unirac.com

U.S. Des. Patent Nos. D496,248S, D496,249S.
 U.S. and other patents pending.

UniRac, Inc. • Albuquerque NM USA • 505.242.6411

INTERNATIONAL

Internet courses: PV, green building & international development. Solar On-Line (SóL) • 720-489-3798 • info@solenergy.org • www.solenergy.org

Internet courses: PV Design & Solar Home Design. Solar Energy International online. Info: see SEI in Colorado listings.

BELIZE

Dec. 5–9, '05. Understanding PV workshop. Design & installation of PV: stand-alone, grid-tie, water pumping & more. Ecovillage Training Center • 970-527-4680 • ecovillage@thefarm.org • www.thefarm.org

CANADA

Sep. 17–18, '05. Campbellford, ON. Resource—Trent Hills RE Showcase. RE exhibits & education. Trent Hills Chamber of Commerce • 705-653-1551 • resource@trenthillschamber.ca • www.energyresource.ca

Oct. 1–2, '05. Toronto, ON. Green Energy Fair. Workshops, tours, demonstrations, vendors, kids' activities & guest speakers on energy efficiency & sustainable technologies. Info: Kortright Centre • 416-661-6600 • info@trca.on.ca • www.kortright.org

British Columbia. BC Sustainable Energy Assoc. meetings at chapters throughout the province • www.bcsea.org/chapters

Calgary, AB. Alberta Sustainable Home/ Office. Open last Sat. of every month, 1–4 PM, private tours available. Cold climate, conservation, RE, efficiency, etc. • 403-239-1882 • jdo@ecobuildings.net • www.ecobuildings.net

CHINA

Sep. 5–6, '05. Beijing. China's Energy Needs & Sustainable Development: Investing in the future. Chatham House • dribeiro@chathamhouse.org.uk • www.chathamhouse.org.uk/china

COSTA RICA

Jan. 23–29, '06. Rancho Mastatal. RE for the Developing World—Hands-On. Solar electricity, hot water, & cooking; biogas & other RE technologies. Coordinator: Ian Woofenden • 360-293-7448 • ian.woofenden@homepower.com

CZECH REPUBLIC

Sep. 7–9, '05. Prague. Green Power Central & Eastern Europe. Utility-scale RE finance & regulatory frameworks. Info: see "Green Power Conferences" under Rome, Italy.

GERMANY

Sep. 22–25, '05. Augsburg. RENEXPO 2005. International Trade Fair & Congress for RE & energy efficiency. Erneuerbare Energien • Unter den Linden 15, 72762 Reutlingen, Germany • 49-712-130-160 • redaktion@energie-server.de • www.renexpo.de

JAMAICA

Dec. 28, '05–Jan. 3, '06. Camp-Ups, RE camp for teens. Discover relationships between energy, nature, spirit, technology & social diversity. Hands-on activities, lectures & recreation. Info: hareef99@yahoo.com • www.youthcamp-us.org •

ITALY

Nov. 23–25, '05. Milan. PV Tech Expo 2005. Conf. for PV manufacturing industry. Info: www.pvtech.it

Nov. 14–16, '05. Rome. Green Power Mediterranean. Policy & networking. Green Power Conferences • info@greenpowerconferences.com • www.greenpowerconferences.com

NEPAL

Kathmandu. School of Renewable Energy Ltd. • 977-01-42-44-003 • sre@nepalmail.com • www.sre.org.np

NICARAGUA

Jan. 2–13, '06. Managua. Solar Cultural Course. Lectures, field experience & ecotourism. Richard Komp • 207-497-2204 • sunwatt@juno.com • www.grupofenix.org

U.S.A.

Oct. 1, '05. Everywhere, U.S.A. National Tour of Solar Homes. Info: Local chapters of the American Solar Energy Society • www.ases.org/about_ases/chapters.htm

Info about U.S. wind industry, membership, small turbine use & more. American Wind Energy Assoc. • www.awea.org

Info on state & federal incentives for RE. North Carolina Solar Center • 919-515-5666 • www.dsireusa.org

Ask an Energy Expert—online or phone questions to specialists. Energy Efficiency & RE Info Center • 800-363-3732 • www.eere.energy.gov/informationcenter

Stand-Alone PV Systems Web site. Design practices, PV safety, technical briefs, battery & inverter testing. Sandia Labs • www.sandia.gov/pv

ARIZONA

Aug. 4–6, '05. Flagstaff, AZ. Southwest Sustainability Expo. Workshops, exhibits, sustainability tours, teen fair & more. Center for Sustainable Environments • 928-523-0602 • julye.evans@nau.edu • www.sustainabilityexpo.com

Scottsdale, AZ. Living with the Sun energy lectures, 3rd Thurs. each month, 7 PM, City of Scottsdale Urban Design Studio. Info: 602-952-8192 • www.azsolarcenter.org

CALIFORNIA

Aug. 20–21, '05. Hopland, CA. SolFest. RE exhibits, alternative transportation, green building, music, speakers & workshops. Info: see Solar Living Institute.

Sep. 24, '05. Ukiah, CA. Ecopalooza 2005. RE workshops & exhibits, solar-powered music, Kids' Town & activities, green businesses, Ecotopia, veggie food, green building demos & more. Ecopalooza Green Living Expos • info@ecopalooza.com • www.ecopalooza.com

Arcata, CA. Campus Center for Appropriate Technology, Humboldt State Univ. Workshops & presentations on renewable & sustainable living. CCAT • 707-826-3551 • ccat@humboldt.edu • www.humboldt.edu/~ccat

Hopland, CA. Ongoing workshops, incl. beginning to advanced PV, wind, hydro, alternative fuels, green building techniques & more. Solar Living Institute • 707-744-2017 • sli@solarliving.org • www.solarliving.org

COLORADO

Sep. 17–18, '05. Ft. Collins, CO. Rocky Mt. Sustainable Living Fair. Exhibits, workshops, speakers, entertainment, vehicle showcase & more. Rocky Mt. Sustainable Living Assoc. • 970-224-3247 • kellie@poudre.com • www.sustainablelivingfair.org

Carbondale, CO. Hands-on workshops & online distance courses on PV, solar pumping, wind power, RE businesses, microhydro, solar thermal, alternative fuels, green building & women's courses. Solar Energy International • 970-963-8855 • sei@solarenergy.org • www.solarenergy.org

Denver, CO. Windhaven RE seminars: Solar Energy Basics, Biodiesel & Alt. Fuels, Wind Energy Basics, Alternative Building, others. Windhaven Foundation for Sustainable Living • 720-404-9971 • windhavenco@yahoo.com • www.windhavenco.org

FLORIDA

Aug. 6–12, '05. Orlando, FL. Solar World Congress. Symposium, workshops & exhibition for International Solar Energy Society & American Solar Energy Society • www.swc2005.org

ILLINOIS

Aug. 13–14, '05. Oregon, IL. Illinois RE Fair. Workshops, exhibits, speakers & music. IL RE Assoc. • 815-732-7332 • sonia@essex1.com • illinoisrenew.org

IOWA

Sep. 10–11, '05. Hiawatha, IA. I-Renew Energy Expo. Workshops, exhibits, food, entertainment. Info: see below.

Prairiewoods & Cedar Rapids, IA. Iowa RE Assoc. meets 2nd Sat. every month at 9 AM. Call for schedule changes. I-Renew • 563-432-6551 • irenew@irenew.org • www.irenew.org

KENTUCKY

Sep. 24–25, '05. Lexington, KY. Bluegrass Energy Expo. Trade show, workshops, exhibits & demos, film festival, kids' activities, energy consultations & more. Appalachia—Science in the Public Interest • 606-256-0077 • aspi@a-spi.org • www.bluegrassenergyexpo.org

MICHIGAN

Aug. 15–19, '05. Dimondale, MI. PV Apprentice Training. Comprehensive PV & electrical education. Classes & hands-on sessions. Great Lakes RE Assoc. • 800-434-9788 • info@glrea.org • www.glrea.org

West Branch, MI. Intro to Solar, Wind & Hydro. Meets 1st Fri. each month. System design & layout for homes or cabins • 989-685-3527 • gotter@m33access.com

MONTANA

Whitehall, MT. Seminars, workshops & tours. Straw bale, cordwood, PV & more. Sage Mountain Center • 406-494-9875 • www.sagemountain.org

NEW MEXICO

Oct.–Nov. & Feb.–Mar. each year. Deming, NM. Intro to Homemade Electricity. Meets 5 Thurs. eves. Mimbres Valley Learning Center • 505-546-6556 ext. 103 • www.wnmu.edu/extuniv/mimbres.htm

Six NMSEA regional chapters have speakers & meet monthly; contact for details. NM Solar Energy Assoc. • 505-246-0400 • info@nmsea.org • www.nmsea.org

NEW YORK

Oct. 27–28, '05. New York, NY. Green Power North America, Green Power Conferences • info@greenpowerconferences.com • www.greenpowerconferences.com

NORTH CAROLINA

Aug. 26–28, '05. Fletcher, NC. So. Energy & Environment Expo. Workshops, presentations, exhibits, clean-air car fair & more. SEEE • 828-696-3877 • info@seeexpo.com • www.seeexpo.com

Sep. 17–18, '05. Beech Mountain, NC. Grid-Tie Wind Installation Workshop. SWWP installation & maintenance. NC Small Wind Initiative • 828-262-7333 • wind@appstate.edu • www.wind.appstate.edu

Pittsboro, NC. RE, biofuels, green building & other sustainable living courses at Carolina Community College. Piedmont Biofuels Coop • 919-542-6495 ext. 223 • www.cccc.edu or www.biofuels.coop

Saxapahaw, NC. How to Get Your Solar-Powered Home. Solar Village Institute • 336-376-9530 • info@solarvillage.com • www.solarvillage.com

OREGON

Cottage Grove, OR. Adv. Studies in Appropriate Tech., 10 weeks, 14 interns per quarter. Aprovecho Research Center • 541-942-8198 • apro@efn.org • www.aprovecho.net

PENNSYLVANIA

Sep. 23–24, '05. Kempton, PA. Penn. RE & Sustainable Living Festival. Exhibits, workshops & speakers on solar, wind, microhydro, hydrogen, green building, biofuel & organic farming. Mid-Atlantic RE Assoc. • yoder4@enter.net • www.paenergyfest.com

Oct. 14–15, '05. Spring Grove, PA. Passive Solar Greenhouse Workshop. Design, construction & year-round production. Steve & Carol Moore • 717-225-2489 • sandcmoore@juno.com

Philadelphia, PA. Penn. Solar Energy Assoc. meetings • 610-667-0412 • rose-bryant@erols.com

SOUTH DAKOTA

Aug. 8–18, '05. Pine Ridge Reservation, SD. Sustainable Training for Native Americans. PV, microhydro, small wind, straw bale, ecological design & wastewater treatment. PennElys GoodShield, Sustainable Nations Development Project • 707-677-3588 • sustainablenations@hotmail.com

TEXAS

El Paso, TX. El Paso Solar Energy Assoc. Meets 1st Thurs. each month. EPSEA • 915-772-7657 • epsea@txses.org • www.epsea.org

Houston, TX. Houston RE Group meetings. HREG • hreg04@txses.org • www.txses.org/hreg

VERMONT

Sep. 21, '05. Burlington, VT. RE Conference. Exhibitors, breakout session & speakers on solar, wind, biomass & alt. fuels. Renewable Energy Vermont • 802-229-0099 • info@revermont.org • www.revermont.org

WASHINGTON DC

Oct. 6–9, '05. Solar Power 2005. Business-to-business solar conf. Solar Electric Power Assoc. • 202-857-0898 • htaylor@solarelectripower.org • www.solarpower2005.com

WASHINGTON STATE

Aug. 5–7, '05. Vashon Island, WA. Island Earthfair. A "created community" with sustainability exhibits, incl. EV & RE workshops & speakers. Island Earthfair • 206-463-1725 • earthfair@jps.net • www.earthfair.org

Sep. 23–25, '05. Walla Walla, WA. NW RE Festival. (25th: Electrathon only). Keynote speakers, workshops (solar, wind, hydro, biomass, energy conservation, alternative construction), tours of wind farm & off-grid/energy efficient homes, children's activities, exhibits & solar-powered music. Info: NW RE Festival Corp. • 509-525-8479 • info@nwrefest.org • www.nwrefest.org

Oct. 8, '05. Guemes Island, WA. Intro to RE. Solar, wind & microhydro for homeowners. Info: see SEI in Colorado listings • Local coordinator: Ian Woofenden • 360-293-7448 • ian.woofenden@homepower.com

Oct. 10–15, '05. Guemes Island, WA. PV Design & Install workshop. System design, components, site analysis, system sizing & hands-on installation. Info: see above.

Oct. 17–21, '05. Guemes Island, WA. Microhydro Power workshop. Design, system sizing, site analysis, safety issues, hardware specs & hands-on installation. Info: see above.

Oct. 24–29, '05. Guemes Island, WA. Wind Power workshop. Design, system sizing, site analysis, safety issues, hardware specs & hands-on installation. Info: see above.

WISCONSIN

Custer, WI. MREA '05 workshops: Basic, Int. & Adv. RE; PV Site Auditor Certification Test; Veg. Oil & Biodiesel; Solar Water & Space Heating; Masonry Heaters; Wind Site Assessor Training & more. MREA • 715-592-6595 • info@the-mrea.org • www.the-mrea.org

WYOMING

Sep. 11–12, '05. Douglas, WY. Roping the Wind Conference. All scales of wind power. Experts, workshops, exhibits. RE Energy Conf. for WY • 307-358-2000 • ewerner@candow Wyoming.com • www.ropingthewind.org



Send your renewable energy event info to happs@homepower.com

solarthermal.com

SOLAR WATER HEATING
IT'S ALL IN THE VACUUM
THE NEW SOLAMAX SYSTEM

Save up to 80%
on heating bills
Commercial • Residential

25 years
of industry leadership

Direct flow design • Lower cost
Highest performance

THERMOMAX™

250.721.4360
zev@solarthermal.com
Toll free fax and mess'g
1.888.923.9443
Ask About Dealerships

MALLARD WIND GENERATORS

Economical, Strong, & Very Reliable

**MALLARD
800E**



SALE

**800 Watt
\$389**

Regular price
\$475

Package
Deal 3-800E
& Regulator
\$1099

We also have charge regulators, tower kits & plans, PMAs, blades, and lots of friendly advice & customer support.

Mike's Windmill Shop

www.mikeswindmillshop.com • 928-532-1607

Major Credit Cards Accepted • Call for Volume Pricing

HYDROSCREEN CO. LLC

- Self Cleaning
- Easy Installation
- High Capacity
- No moving parts
- Pipe, ramp and box mountings

**Precision Wedge Wire
Coanda Screens**
for Hydro, Agricultural, and
Domestic Diversions from
10 gpm to 500 cfs

- We specialize in creatively engineering solutions for your unique hydro diversion screening needs.
- Our solutions are cost effective with numerous screen mounting options; we also have durable 304 SS mounting boxes.



Visit us at www.hydroscreen.com or
call (303) 333-6071

e-mail: RKWEIR@AOL.COM

Mention this ad for special savings!

RENEWABLE ENERGY SOLUTIONS!

**WIND POWER
MICROHYDRO
GENERATORS &
ALTERNATORS**



**HUMAN POWER
GENERATOR**

WINDSTREAM POWER SYSTEMS INC.

PO Box 1604 HP, Burlington, VT 05402 Tel 802 658 0075 Fax 802 658 1098
Info@windstreampower.com • www.windstreampower.com

Independent Power Systems Throughout the World - Our 29th Year

Solar Panels • Wind Turbines • DC Lighting



ABS Alaskan, Inc.

Alternative Energy & Remote Power

2130 Van Horn, Fairbanks, AK 99701

toll free: 800-235-0689 fax: 907-451-1949

visit us online: www.absAK.com

Alaska Battery Anchorage, AK ph: 907-562-4949 fax: 907-563-4900
Distribution Center Reeson, WA ph: 425-251-5745 fax: 425-251-5748

Micro-Hydro • Complete Systems • & More

adopt a library!



When Karen and I were living with kerosene lamps, we went to our local public library looking for a better way to light up our nights. We found nothing about small-scale renewable energy. As a result, one of the first things we did when we started publishing *Home Power* sixteen years ago was to give a subscription to our local public library.

If you'd like to do the same for your public library, we'll split the cost of the subscription with you. Inside the U.S., you pay \$11.25 and we'll pay the rest. Outside the U.S., the same offer stands, so call us for rates.



— Richard Perez, Publisher

Check with your local library before signing them up. Eligible libraries must be open to the general public.
PO Box 520, Ashland OR 97520 • 800-707-6585 • 541-512-0201 subscription@homepower.com • www.homepower.com

questions & answers

Grid-Tie Inverter

I have about 320 watts of solar-electric panels that I would like to connect to my home to slightly reduce my electric bill. Do I need to use a grid-connect inverter? Since 320 watts is small compared to my total energy consumption, do you think I could use a modified square wave inverter without affecting the quality of the grid-supplied electricity? Shannon Fields • sf@udel.edu

Hello Shannon, If you are going to sell electricity to the utility, you need a utility intertie inverter—one specially designed to sync with the grid. Currently, the smallest utility intertie inverter available is the 700-watt Sunny Boy SB700, manufactured by SMA America (www.sma-america.com).

Modified square wave inverters cannot sell electricity to the utility grid. You could set up a small battery-based inverter system independent of the grid, to power a circuit or two in your home. Richard Perez • richard.perez@homepower.com

Heat-Tolerant Pipe Insulation

I have a simple question. I want to insulate the pipes on my solar hot water panel, and I've been having trouble finding info on the heat tolerance of various foam wraps, tapes, etc. I'd like to use a tight-fitting foam wrap and cover this with foil-covered foam tape. I'm thinking about wrapping the pipes with fiberglass and then putting an outer pipe of PVC around it for protection. Is this OK, or will I get 235-degree, melted goo? Help! Thanks, John in Alabama • jmorris@prn-inc.net

Hi John, Good question! There are only two types of insulation I would use on copper tubes used in collector loops on solar hot water systems—fiberglass and black closed-cell pipe insulation. The black closed-cell insulation has trade names like Armaflex, Rubatex, and Halstead Tube. The gray or white foam insulation available at home improvement stores is fine for regular hot water pipes, but will melt in most situations on collector-loop piping. Both black closed-cell and fiberglass insulation should be weatherproofed. Architectural grade aluminum, PVC, rain gutter material, foil tape, and very light-gauge galvanized steel are all good options—some better than others depending on local climate conditions. Hope this helps, Chuck Marken • chuck.marken@homepower.com

Chicken Lamp

I am building a chicken coop that is several hundred feet from my grid-electricity source. I want to design a renewable energy system to operate a lamp to keep the chicks warm—perhaps a 100-watt bulb. Is this doable? If so, how? Thank you, Gareth McMullen, Seabeck, Washington • mcmullengl@kpt.nuwc.navy.mil

Hi Gareth. Doing significant electric heating with photovoltaics (PVs) is not usually recommended. For example, if your 100 W light needed to be on for, say, ten hours a day in the winter, your PV system would need to produce an average of 1,000 watt-hours of energy every day.

Leaving system inefficiencies aside, if Seabeck gets three sun hours a day in the winter (and it could be even less), your minimum

PV array output would need to be 333 watts. Because PVs rarely operate at their rated output, you would likely need about 400 rated watts. Right now, retail PV sells for US\$4.50 to \$5 a watt, so you are talking US\$2,000 just for solar-electric panels.

And that's not all, because most, if not all, of those ten hours will be at night, when the PVs are not making any energy. You will need batteries, which are also relatively expensive. If you need batteries, you will need a charge controller. The costs are mounting.

But, don't give up on this project. If you insulated the area to be heated, made it the absolute minimum size necessary, and built insulated doors that could be closed at night, you would be able to get by with a much smaller heater.

In addition, if you added some thermal mass (like some water containers) to the chick habitat, then heated the water while the sun shines (either using your PV-powered heater or direct sunlight), you could greatly reduce the need for batteries to run a heater all night. Finally, putting a thermostat in so that the heater would not stay on unless it was needed could save some energy that would otherwise be wasted by overheating.

I know that it seems like we just designed the Chick Hilton, but really I am just trying to save you some money. I bet you can find more information by searching the Web for "solar chicken coop" or other similar phrases. Michael Welch • michael.welch@homepower.com

Hi Gareth, I think a less expensive option might be to put in a solar hot water system for heating the coop—a closed-loop system with some mass to store the heat overnight. When I was a kid, my grandmother always kept a jug of hot water, wrapped in a towel, in with the chicks at night. They would huddle up next to it to sleep, just like it was the mother hen. I bet you could really make them happy with a solar-heated setup. Linda Pinkham • linda.pinkham@homepower.com

Matching PVs for MPPT

I would like to add to my solar-electric array and get a larger battery bank. My charge controller is a dutiful Heliotrope CC60, but since it is older and may fail, I am looking at the newer MPPT charge controllers. What are the panel specifications that need to be closest to allow a MPPT to function best? I cannot add more of the same panels to my old rack. Of course I am looking at brand name and cost per watt. Do I choose based on amps, voltage, or the shape of the power curve? What about the same panel-mixing situation while using the old controller? Thanks as always. Jim Marquardt • marqu009@umn.edu

Hi Jim, Adding an MPPT controller to an existing system is a very popular upgrade these days as people improve and expand their systems. MPPT controllers will get the most out of your PV array, and actually are more beneficial in off-grid applications because they produce the most benefit in the cold winter months when the batteries tend to be at a lower state-of-charge—right when you need the energy the most!

Using an MPPT controller with old and new panels can be done, but there are some limitations. The basic idea is to match the new panels as much as possible with the old ones to ensure

that you get the maximum power from both sets. Using an MPPT controller that does a "true" MPPT routine, where it varies the operating voltage to find the maximum power point, is recommended. Some MPPT controllers just operate at a fixed ratio from the open circuit voltage, which is not ideal when the PV array is made up of different panel brands or ages.

The basic idea is to make sure the different PV modules have the same number of cells in series and are the same type—single crystal or polycrystalline. Do not mix brands of PV modules in series. Only connect series strings of the same PV modules in parallel with series strings of different PV modules.

You should also consider increasing the voltage of the PV array when doing the upgrade, to reduce the losses in the wiring between the PV array and the step-down-type MPPT controller. Some brands allow the array to be wired as high as 72 VDC nominal (six, 12 VDC PV panels or three, 24 VDC PV panels in series) and still have a 12 VDC or 24 VDC battery system. This can save you a lot of time and money because you may then be able to use the existing wire. With the voltage doubled, tripled, or more, the losses can actually be reduced while the wire is carrying higher power. Sometimes the savings in replacing the wiring can be more than the cost of the new MPPT controller, so the upgrade is "free" and you still get the MPPT benefits.

Mixing brands of PV panels with a non-MPPT controller can be done as well. In some ways, these controllers are more tolerant of performance differences in mixed arrays. But using a non-MPPT controller results in reducing the overall performance of the panels, which means less energy produced. Christopher Freitas, OutBack Power Systems • cfreitas@outbackpower.com



SJ C **SAN JUAN COLLEGE**
FARMINGTON, NM

Earn a degree in Renewable Energy
with a concentration in Photovoltaic Design and Installation

- ◆ Two-year AAS degree or one-year certificate. Both emphasize full NEC compliance.
- ◆ Combine science with hands-on learning.
- ◆ Tuition \$420/semester out-of-state and \$300 in-state.

Tom Munson, (505) 566-3003 or (800) 241-6327
munsont@sanjuancollege.edu
www.sanjuancollege.edu/reng

Increasing energy costs driving you crazy?
Take control with Sunda vacuum tube technology for year round solar water heating - Domestic Hot Water, Home Heating, Pools & Spas, Agricultural and Industrial Applications



Dealer Inquiries Welcome!

Features

- Higher efficiencies in cold and overcast conditions
- Easy installation & servicing
- Attractive pricing

Sun Spot Solar & Heating, Inc.
Website: www.sssolar.com / Email: info@sssolar.com
Tel: (570) 422-1292
U.S. Sales Agent for Sunda Evacuated Tube Collectors

Intentional Communities



Dedicated to communicating the experience and wisdom of intentional community.

We've been at it for 30 years, and nobody covers the world of community like Communities magazine.

1 year subscription \$20 (\$24 Canada)
Sample issue \$6 (\$8)

800-462-8240 fic.ic.org/cmag

Coaxial Evacuated Vacuum Tube Solar Collector



SRCC Certified
Residential & Commercial
1kW thermal collector--\$935
Solar water heating
Radiant floor heating

www.btf solar.com
BTF Ltd. POB 409 Fennville MI 49408 USA
Tel. 269-236-6179 info@btf solar.com

BATTERY BOX VENTILATOR & BACK DRAFT DAMPER



- Positive hydrogen venting
- Stops back drafts
- Minimal power consumption

* Available from dealers and distributors across the U.S. and Canada

POWER VENT
12v & 24v – \$79
48v – \$104
+ \$10 S&H (cont. U.S.)

Zephyr Industries, Inc.
POB 52, Salida, CO 81201
719.530.0718
www.zephyrvent.com

HYDROELECTRIC SYSTEMS:

Pelton and Crossflow designs, either complete turbines or complete systems. Assistance in site evaluation and equipment selection. AC Systems for standalone or grid interconnect operation. Manufacturing home and commercial size turbines since 1976. Send for a free brochure. Canyon Industries Inc., P.O. Box 36 HP, Deming, WA 98244, 360-592-5552. e-mail: citurbine@aol.com web page: canyonhydro.com • HP10802

EARTH SHELTERED HOMES This definitive manual by noted authority Loren Impson features detailed building instructions for amazingly affordable and practical Ferro Cement Domes. Only \$15 from Loren, 71 Holistic, Mt. Ida AR 71957 www.2BbyD.com • HP10803

COSOLAR.COM discount prices from Colorado Solar Electric. OutBack Inverters in stock 1-800-766-7644 • HP10804

SINGLE AND DUAL AXIS SOLAR TRACKER CONTROLS up to 48V and 5A output. www.theanalogguy.com • HP10805

SURPLUS INDUSTRIAL BATTERIES: Save up to 70% on unused military and industrial batteries. Many types and sizes, super H.D. Factory crated. Also chargers, wind and solar equipment, new and used. D.P.S.D. Inc. 3807 W. Sierra Hwy. #6, Acton CA 93510. 661-269-5410. Fax 661-269-3601. • HP10806

DVDs AVAILABLE: NEW-"ELECTRIC CAR CONVERSIONS," "Guerilla Solar Install," "Intro to Solar Power," "Intro to Solar Pool Pumps," "Solar Installation" www.igotsolar.com • HP10807

ECOMALL: The largest environmental portal of earth-friendly companies and resources. Renewable energy companies, news and information. www.ecomall.com. To advertise, call 845-679-2490 • HP10808

LARGE GAS REFRIGERATORS 12, 15 & 18 cubic foot propane refrigerators. 15 cubic foot freezers 800-898-0552 Ervin's Cabinet Shop, 220 N County Rd. 425E., Arcola, IL 61910 • HP10809

XXXXXXXXXXUNI-SOLARXXXXX
XXXXXX 64 Watts \$319 XXXXXXXX
M55 Siemens panels \$260/SQ 80
watts \$350. New 1500 AH Absolight
12V batteries \$1900. TraceX SW5548
\$2450. Ex 2KW inverter SB \$850.
Buy, sell New/Used 760-949-0505 •
HP10810

HONDA GENERATORS - 1000 to 10,500 watts. Fast shipping and great prices! www.hayesequipment.com 1-800-375-7767 • HP10811

DC SUBMERSIBLE WELL PUMPS. Complete, ready to install. \$187 includes IMMEDIATE FREE SHIPPING. Visit www.nemosolar.com or call 1-877-684-7979 • HP10812

I AM A SOLAR WHOLESALER looking for retailers to carry my solar electronic and hobby goods. Phone # (916) 486-4373. Please leave message. • HP10813

TELLURIDE COLORADO: Off the Grid Properties! Hot Springs, Riverside, solar powered homes, large and small ranches. Find your own place in the sun with the only solar powered real estate office in Colorado. T.R.I. (970) 728-3205 1-800-571-6518 www.solarrealty.net • HP10814

EDTA RESTORES SULFATED BATTERIES. EDTA tetra sodium salt, \$12/lb. plus \$5 S&H for 1st lb. plus \$1 S&H for each additional lb. Trailhead Supply, 325 E. 1165 N., Orem, UT 84057, (801) 225 3931, email: trailheadsupply@webtv.net, info. at: www.webspawner.com/users/edta. • HP10815

SOLAR HEATERS FOR SALE! Get free heat from the sun for your home, office, garage, etc. Visit us today at www.hotboxsolar.com or by phone at 1-607-481-0992. HotBox Solar. 263 Glenwood Ave. Elmira Heights, NY. 14903 • HP10816

VARI-CYCLONE: DC powered ceiling fan, 40% more airflow with no increase in power consumption. For more info contact RCH Fanworks, the #1 manufacturer of DC powered ceiling fans, 2173 Rocky Crk. Rd. Colville, WA 99114 PH: 509-685-0535, email: info@fanworks.com, Web: www.fanworks.com, Dealer inquiries welcome. • HP10817

SURVIVAL UNLIMITED.COM - Emergency Preparedness & Survival Supplies. Wind Power from 439.00+. Many great products & prices! 1-800-455-2201 www.survivalunlimited.com • HP10818

CONVERT WOOD TO ELECTRICITY: Complete 7 KW 120/240VAC steam engine powered generator sets ready to run. steamgen@juno.com www.geocities.com/steamgen 918-520-7711 • HP10819

WWW.EARTHTOYS.COM - Online library and emagazine all about alternative energy systems and equipment • HP10820

50+ Custom MICROHYDRO TURBINE sizes in stainless or plastic, brass nozzles 5-29mm, arbors, site study tools, www.H-Hydro.com • HP10821

MOVE TO BEAUTIFUL, SCENIC N. IDAHO! We have many alternative energy homes to choose from. www.maidenrock.com Maiden Rock RE Sandpoint, ID 1-877-428-7370 • HP10822

SOLAR BATTERIES Absolyte Telecom PV Batteries (100-A series) maintenance-free, non-gassing, freeze-tolerant, priced comparable to lead acid. 866-SOLAR-99 www.solarunlimited.net • HP10823

SOLAR HOT WATER SYSTEMS - MANUFACTURING - SALES - SERVICE - WIND - WATER - SOLAR - BIODIESEL. Dealer Inquiries Welcome. Trimline Design Centre Inc 6772-99 Street Edmonton AB CAN T6E 5B8 780 466-9034 www.trimlinedesigncentre.com • HP10824

GOING BANANAS? Produce more than just power in this 2500 sq ft log solar home on 43.8 ac. 1200 amp hour AGM battery bank, 4000w Trace inverter, 10,000w generator, features galore...and the sunny atrium boasts its own banana trees! Central Colorado mtns. Call Geri@719-689-2008 www.guffeylandcompany.com • HP10825

SOLAR CELLS New 5" monocrystal 50 per pack - 125 watts \$150.00 make your own solar panels email for specs: none1120@juno.com • HP10826

OVERCOME YOUR ENERGY DEPENDENCE WITH SOLAR. COMPLETE SELECTION of reliable solar energy products for everyday living. Just about anything using electricity can be solar powered—cost efficiently. Free catalog. www.DiscoverPower.com 858-581-0051 Or 800-842-5678. Discover Power • HP10827

SUPER EFFICIENT WINDOW & DOOR SYSTEMS. Bruckner R world leader in passive house, triple seal, tilt & turn windows from Austria now avail in USA. U value of .28 on std units, as low as .18 on passive house units. Automatic or manual roll shutters. Pls contact Chris Hurst 209-743-2638 Fax 209-928-3893 hurstconstruction.biz • HP10828

NEW IN BOX TRACE INV SW 2512 w/ remote w/50 Ft cable. Last one made in U.S \$1800 OBO. 206 986 2900 L message • HP10829

1.5KW BERGEY. 78' guyed tower Like new. \$4500 lelliott@quantumenergygroup.com • HP10830

WANT TO LIVE RENT-FREE - anywhere in the world? There are empty homes in every state and country, and property owners are looking for trustworthy people to live in them as property caretakers and housesitters! The Caretaker Gazette contains these property caretaking/housesitting openings in all 50 states and foreign countries. Published since 1983, subscribers receive 1,000+ property caretaking opportunities each year, worldwide. Some of these caretaking and housesitting openings also offer compensation in addition to the free housing provided. Short, medium and long-term property caretaking assignments are in every issue. Subscriptions: \$29.95/yr. The Caretaker Gazette, PO Box 4005-E, Bergheim, TX 78004. (830) 336-3939. www.caretaker.org • HP10831

TUCSON, ARIZONA OFF-GRID STRAW BALE HOME on 4 secluded acres. Thermomax solar hot water system. 1050 SF greenhouse. www.solarhaven.org • HP10832

SOLAR ELECTRIC STATE REBATE If you don't want to wait from 30 days up to 365 call us. We can also help to raise or improve cash flow as an advance against accounts receivables and invoices. 619-733-9439 Ask for Alex • HP10833

SUNELEC.COM has a BRAND NEW STABER WASHING MACHINE on sale for \$800! Also laminates for as low as \$2.90/watt. We also sell refurbished Xantrex inverters with factory warranty at huge savings. Of course we sell tons of brand new name brand modules & inverters. 30+ yrs in solar. Order line 305 536 9917. Info@sunelec.com • HP10834

Readers' Marketplace Rates

Rates: 25¢ per CHARACTER, include spaces & punctuation. \$20.00 minimum per insertion. All Readers' Marketplace ads are published in both the print and Web versions. Please send a check or Visa, MasterCard, American Express, or Discover card data with ad. Please, no money orders. We do not bill Readers' Marketplace ads; they must be paid for in advance of publication. Your cancelled check or credit card bill is your receipt.

Submit your ad by:

- **E-mail:** (preferred) readersmarketplace@homepower.com;
- **Fax:** 541-512-0343;
- **Phone:** 800-707-6585 or 541-512-0201

Help us prevent fraud! *Home Power* Readers' Marketplace ads from individuals must supply serial number(s) for equipment being sold. Businesses must supply published phone number(s) and a physical address. While *Home Power* is doing everything we can to prevent fraud, we can assume no responsibility for items being sold.



installers directory

Do you want a renewable energy system, but don't want to install it yourself? You deserve a system that meets your expectations and budget! A renewable energy professional will design and install a safe, code-compliant system, and offer you service and support after the sale. Check out the state-by-state installer listings below.

Home Power does not guarantee the quality provided by the businesses listed below— please shop carefully, request references and certifications, and compare.

Alaska

Remote Power Inc.

Remote Power Inc., Greg Egan, President. Licensed electrician since 1982. Outback certified field service technician. MREA trained wind system installer. Design, installation, sales & service of wind, pv, & hydro systems. We have affiliated installers statewide. Bush jobs no problem. We stock inverters, PV panels, efficient appliances, etc. at our shop near Fairbanks. Call 1-888-257-3639 or 1-907-457-4299

Arizona

www.gswpowersystems.com

Generator Solar & Wind Power Systems Design, Sales, installation & maintenance. Off-grid & grid-tied, prime power or back-up. Complete systems, hybrid systems, or sub systems & components. We can do it. Covering all of Arizona & dedicated to helping all present & potential customers. Ralph Odonal, license # ROC203166. (928) 639-2297, (928) 300-4067, altpwrsys@hotmail.com



Good Power Company, Stand Alone or Grid Tie systems for homes, business, solar wells and outdoor lighting. Solar, wind and motor generator systems. Licensed contractor serving ALL of Arizona. Remote home specialist! Free estimates. Call Dave Haycock for prompt courteous design, sales, installation and service. (520) 560-3856, espdave@hotmail.com. References. ROC195768



Northern Arizona Wind & Sun, of Flagstaff, Arizona, has designed and installed thousands of solar electrical systems since 1979. Call or email us for a design quote for Residential Utility Tie, Remote Home, Water Pumping, or Telecommunication System at 800-383-0195, email windsun@wind-sun.com, or visit our website at <http://store.solar-electric.com/index.html>. Licensed #ROC 089239.

California



Acro Electric is a full service, turn-key, res.& comm. solar electric contractor. We design, install, & handle all necessary CEC, utility forms and contracts. Quality installations are backed by 32 years electrical experience. Approved by the League of California Homeowners (www.homeowners.org) & Better Business Bureau (www.midcalbbb.org). Free site analysis & brochure. (866)711-ACRO • www.acroelectric.com



Akeena Solar is the nation's largest residential solar electric installer with two NABCEP-Certified PV Installers on staff. Our design/build services coupled with our complete financial analyses, based on actual site conditions, support our growing list of satisfied customers in making the switch to clean reliable energy. Serving CA, NJ, MA, RI, CT, & NY. Visit www.akeena.net or call 888-akeena-8



Carlson Solar. has been serving Southern CA since 1988. We are a licensed, bonded, and insured solar-electric installation company, specializing in both grid-tie and off-grid systems. We are NABCEP certified and take great pride in our excellent customer service. Saving the environment one house at a time. Call toll-free 1-877-927-0782 or visit us at www.carlsonsolar.com



Cobalt Power Systems Inc. is a full-service, licensed installer of PV systems in the SF Bay Area. We offer free consultations, detailed proposals, professional system design by an electrical engineer, expert installations, and competitive pricing. We handle all the paperwork for the client, and we oversee all inspections. Please contact us at 650-948-9574 or www.cobaltpower.com.

California, cont.

EcoEnergies

EcoEnergies is recognized as Northern California's leading Renewable Energy Experts. We specialize in Solar Electric, Cogen, and Wind powered systems. Our entire engineering staff is NABCEP certified and dedicated to unparalleled quality, customer service and customized solutions. Start saving Your Money while saving Your world! Call for Free Estimate 1.866.765.9463



Electron Connection Licensed in CA and Oregon. NABCEP Certified installer. Serving northernmost California and southern Oregon. PV, wind, microhydro installs. (800) 945-7587 email: bob-o@electronconnection.com, www.electronconnection.com



Empower Energy, Southern CA. We design, sell, install, & service high quality residential & commercial solar, wind, & hydro systems. Specializing in grid-tied & remote stand alone systems in any part of CA. Make renewable energy a part of your home, ranch, or business. Lic. in CA since 1995, (#711993). Cert. SMA & Sharp installer. 818 222-8700, toll free 800 494-2366, EmpowerEnergy.net, Info@EmpowerEnergy.net.



Feather River Solar Electric Bill Battagin of Taylorsville has been designing, installing and servicing renewable energy systems since 1982. PV, micro-hydro, hybrids; grid intertie or stand alone systems. CA Elect.l Lic. # 681552, Outback Cert. Tech. We live and work with RE. Serving Plumas, Lassen, Sierra, Butte Cos. 530.284.7849 frenergy@psln.com, www.frenergy.net



Independent Energy Systems, Serving the Santa Cruz/Monterey Bay Area. We specialize in design, installation and sales of residential/commercial PV systems. Our mission is to provide our friends in the community an opportunity to become part of the future in renewable energy. We are based in Santa Cruz, we love what we do and it shows in our work! Ph: 831-477-0943 or visit www.iesolar.com



Offline Independent Energy Systems, Since 1983. An electrical contracting co., we specialize in utility intertie (with state rebate & net metering) & off grid systems. Owned & operated by Don & Cynthia Loweberg in Central CA East of Fresno. Don Loweberg NABCEP Certified Installer. POB 231, North Fork, CA. 93643, (CA lic# 661052) ph 559 877 7080, fx 559 877 2980, ofln@aol.com www.psnw.com/~ofln



Owens Electric & Solar, Providing quality power solutions since 1964. Full range of energy conservation & turnkey services including efficiency upgrades & PV solar system installations for residential & commercial applications. Licensed, bonded, certified, & insured C-10 Electrical Contractor (#464389) serving northern CA. 1-877-57-SOLAR. info@owenselectricinc.com www.owenselectricinc.com



Solar Wind Works specializes in consultation, sales, design, service, & installation of complete RE systems. US Distributor for Proven Wind Turbines. We supply all components. Grid-connected or grid-independent. Truckee, CA 530-582-4503, 877-682-4503, NABCEP Certified Installer. CA Contractor's Lic # 796322 chris@solarwindworks.com, www.solarwindworks.com

Canada



Energy Alternatives has been serving Canadians for over 20 years. A licensed electrical contractor (BC Lic # 86683) with professional installers throughout Canada. Expert consultation & design services, turn-key installed systems or DIY packaged system kits. Extensive inventory for fast delivery. Visit www.EnergyAlternatives.ca, Call 1-800-265-8898. Canadian dealer inquiries welcome.

Colorado



Burnham-Beck & Sun, Solar & Wind Energy Systems. Located in Fort Collins, Colorado, we make site evaluations, system designs, and installations in Northern Colorado, Southern Wyoming. We drop-ship equipment anywhere in the US. Retail products include PV modules, wind turbines, inverters, batteries, efficient appliances. 970-482-6924. mailto: BurnhamBeckSun@aol.com. www.burnhambeck.com



Solar Solutions Ltd. provides photovoltaic, wind & hybrid power systems & components for stand alone systems, grid tied, RV's & remote water pumping. Committed to providing the highest quality service & customer satisfaction. A proud member of Colorado SEIA and a lifetime member of the Colorado RE Society and ASE. Xantrex Certified Dealer. 888 44solar or 888 447-6527 www.solarsolutions.com

Connecticut



Akeena Solar is the nation's largest residential solar electric installer with two NABCEP-Certified PV Installers on staff. Our design/build services coupled with our complete financial analyses, based on actual site conditions, support our growing list of satisfied customers in making the switch to clean reliable energy. Serving CA, NJ, MA, RI, CT, & NY. Visit www.akeena.net or call 888-akeena-8

Florida



ECS Solar Energy Systems (tel) 352-377-8866 www.ECS-solar.com / tom@ECS-solar.com We service FL, the Caribbean and the Southeastern U.S. FL's first solar contractor since 1977. Solar pool heating, hot water, and electric systems –commercial & residential. Solar lic. # CVC056643 Florida state certified for "grid-connected" systems. Contact us now to receive a free solar informational booklet.

Mexico



SC Solar designs/install PV systems—residential, US military, solar lighting, water pumping, traffic management power systems. Solar thermal & micro hydro. Custom UPS systems for off grid. Installation area: NC, SC, VA, GA, TN, & Mexico. For more info & credentials: 803-802-5522 www.scsolar.com CCR# & Cage Code #1SLJ5.

Michigan



Backwards to the Future Ltd. installing, designing and supplying solar equipment since 1986. OEM supplier of evacuated tube heat pipe technology for DHW & hydronic heating. Systems building integration by joint venture with registered architect. State licensed residential builder & solar mechanical contractor. POB 409 Fennville MI 49408 tel: 269 2366179 email: info@BTFsolar.com www.BTFsolar.com

Minnesota



Innovative Power Systems: The leading provider of solar-electric & solar thermal systems in the Twin Cities. IPS sells, designs, installs, & services solar systems. 2 NABCEP Certified Installers on staff. Since 1990, we have been helping homeowners, businesses, and community organizations make the transition to clean, ubiquitous energy. www.ips-solar.com. 612-623-3246. info@ips-solar.com

Montana



Oasis Montana Inc: Designs, sells, & installs renewable energy power systems in North America and also offers efficient and gas appliances. Our engineer Dan Healy is a NABCEP Certified Installer. Toll-free: 877-OASISMT or 877-OASISPV. Web sites: www.oasismontana.com, www.grid-tie.com, www.PVsolarpumps.com. E-mail: info@oasismontana.com



Planetary Systems, Inc. In business 10+ years. Sales/design/installation of complete RE electrical, water & hydronic heating systems. Our patented RE "Power Package" simplifies installation & reduces costs. Can be shipped nationwide & installed locally. CAD schematic system drawings/technical support provided. Xantrex Certified Dealer. Phone (406) 682-5646, www.planetarysystems.com

Nevada



Alternative Energy Solutions, Reno, Nevada. We design, sell, install and service PV, wind, off grid and grid tie RE systems, Nevada State Licensed and Bonded Contractor, NABCEP PV Certified Installer. Xantrex / Trace Authorized Service Center, Xantrex Certified Dealer, Outback Factory trained field service technicians and Certified Uni-Solar field laminate installer. 775-857-1157 toll free 1-866-491-SOLR



Solar Unlimited, Inc. serves Nevada's Renewable Energy design, sales, service, and installation needs, including PV, wind, net-metering and off-grid systems. We are authorized dealers for Solarwall, Gillette, Xantrex, Outback, African Wind Power and more. Licensed and insured. Call toll free 866-SOLAR99 or visit www.solarunlimited.net.



Solar Wind Works specializes in consultation, sales, design, service, & installation of complete RE systems. US Distributor for Proven Wind Turbines. We supply all components. Grid-connected or grid-independent. Truckee, CA 530-582-4503, 877-682-4503, NABCEP Certified Installer. NV Contractor's Lic # 59288. chris@solarwindworks.com, www.solarwindworks.com

New Hampshire



Sunweaver Incorporating innovative technologies for power, water and heat. Encouraging knowledge and direction towards resource responsible solar living. Installing in New England and the Carribean since 1985. www.sunweaver.org. mailto: info@sunweaver.org 603-942-5863 Showroom hours: Monday-Saturday 11am-6pm

New Jersey



Akeena Solar is the nation's largest residential solar electric installer with two NABCEP-Certified PV Installers on staff. Our design/build services coupled with our complete financial analyses, based on actual site conditions, support our growing list of satisfied customers in making the switch to clean reliable energy. Serving CA, NJ, MA, RI, CT, & NY. Visit www.akeena.net or call 888-akeena-8

New Mexico



Positive Energy Inc. High quality renewable power systems. Licensed, bonded, and insured electrical contractor serving Santa Fe and northern NM. Owner Allan Sindelar is NABCEP certified and is a certified dealer/installer for Xantrex, Outback, and Sunnyboy. 505 424-1122. E-mail: info@positiveenergysolar.com. Website: www.positiveenergysolar.com

New York



Akeena Solar is the nation's largest residential solar electric installer with two NABCEP-Certified PV Installers on staff. Our design/build services coupled with our complete financial analyses, based on actual site conditions, support our growing list of satisfied customers in making the switch to clean reliable energy. Serving CA, NJ, MA, RI, CT, & NY. Visit www.akeena.net or call 888-akeena-8



Daystar Energy Systems We're making it easy to choose renewable energy. Unparalleled pricing guarantee, exceptional installation service, and backed up with a comprehensive warranty. Not your average installer, ask about our Sweat Equity and Referral Incentive Programs. Putting customers first in NY and NJ. Call Desi 585-224-9105 www.daystarenergysystems.com



Solar & Wind FX Inc. NY's only Off-grid Design & Training Center, where a client can see the latest RE & Green building technologies. A family owned, full service company focusing on Western NY that provides site evaluation, design, installation & the all important, service after the sale. Member of NESEA & NYSEIA, SEI alumni & a NYSERDA installer. 585-229-2083, solarandwindfx.com

New York, cont.



Suntric Renewable Electric Systems, Experienced, qualified installers of photovoltaic, wind, and micro-hydro stand alone systems. Located on the western end of the Adirondack Park in northern New York State. Site evaluations, design consultations, sales and service. Off grid since 1976. Edwin & Pamela Falk, 6920 Abbey Road, Lyons Falls, New York 13368 • 315-348-6893

North Carolina



Solar Village Institute, Inc. NC's premier solar, wind, micro-hydro dealer-installer-educators. Off-grid since 1992. Top quality, pro work, guaranteed. NC, SC, VA, GA, AK. Specializing in Wind/Solar hybrid off-grid systems. New/remodels. Christopher W. Carter, Pres. SEI alumni, Xantrex Cert. dealer. David Del Vecchio, installation manager. www.solarvillage.com, chris@solarvillage.com, 800 376 9530

Ohio



REpower Solutions: Northeast Ohio's renewable energy installer for home and business. Design, installation, and education for PV and wind systems. NABCEP Certified Installer. Xantrex Certified Installer. e-mail: power@repowersolutions.com. Website: www.repowersolutions.com. P.O. Box 91992, Cleveland, OH, 44101. 216-402-4458.



Third Sun Solar & Wind Power, Ltd. is Ohio's leading renewable energy contractor. Complete design and installation of off-grid, utility tied, PV and wind systems in OH, KY, IN, IL, MI, PA, WV. Owner Geoff Greenfield is NABCEP Certified Solar PV Installer. We are committed to excellent customer service & the highest quality systems. www.third-sun.com. (740) 597-3111.

Oregon



Electron Connection Licensed in CA and Oregon. NABCEP Certified installer. Serving northernmost California and southern Oregon. PV, wind, microhydro installs. (800) 945-7587 email: bob-o@electronconnection.com, www.electronconnection.com



Mr. Sun Solar: Since 1980, the Northwest's leading solar installer. Over 1,200 projects including solar hot water, solar pool heating, solar attic fans, and on- and off-grid PV systems. Dealer for Sol-Reliant™, The Solar Water Heater Built to Last - OG-300 and Bright Way™ approved. Phone: (888) SOL-RELY (888-765-7359). Web: www.MrSunSolar.com and www.SolReliant.com



Solar/wind Power of Portland, and our partner, Inland Electric, installers of solar electric & hot water systems, wind power, & solar shades, serving the Portland/Vancouver Metro area. Oregon Energy Trust ID #10012. Free information packet, or visit our showroom: 10006 SW Canyon Rd., Portland, OR 97225. Phones: 503/297-5781, or 800/550-2950. WEB: www.solarwindpdx.com, solarwind@ecosky.com.

Pennsylvania



Appalachian Wind Systems, LLC has been serving PA, WV & MD for 6 years. Distributor for Cyclone wind turbines, Synergy wind turbines, Sun solar panels, LED lighting, stand alone & grid tie inverters and other products. Site evaluations and financial analyses. We also sell, service & install 10-60 meter NRG meteorological towers & first stage wind analysis. For more information, call 724-452-0326

South Carolina



SC Solar designs/install PV systems—residential, US military, solar lighting, water pumping, traffic management power systems. Solar thermal & micro hydro. Custom UPS systems for off grid. Installation area: NC, SC, VA, GA, TN, & Mexico. For more info & credentials: 803-802-5522 www.scsolar.com CCR# & Cage Code #1SLJ5.

Texas



Meridian Energy Systems specializes in the design and installation of high quality solar and wind energy systems throughout the State of Texas...and beyond. Factory trained technicians and NABCEP Inaugural Certificate on staff. Visit our website www.meridiansolar.com or call toll-free: 888-477-3050

Texas, cont.



North Texas Renewable Energy Inc. North Texas' premier solar and small wind energy service. Complete system design and installation. Available service contract Independence-Reliability-Conservation. Jim Duncan answers@NTREI.com 817.917.0527

Utah



Solar Unlimited, Inc. Southern Utah's leading design, sales, service and installation professional for all your alternative and Renewable Energy needs, including PV, wind, net-metering or off grid systems. We are authorized dealers for Solarwall, Gillette, Xantrex, Outback, African Wind Power and more. Licensed and insured. Call toll free 866-SOLAR99 or visit www.solarunlimited.net.

Vermont



Vermont Solar Engineering has provided the finest in renewable energy throughout New York and New England, since 1991. We design, install, and support solar electric, wind electric, and solar hot water systems. K. Herander, NABCEP™ certified installer. Xantrex Certified Dealer. NYSERDA eligible installer. Vermont Solar and Wind Partner. www.vermontsolar.com 1-800-286-1252

Virginia



Dunimis Technology Inc. Providing alternative energy systems since 1992. NABCEP certified solar technicians on staff. We specialize in the more demanding upscale off-grid residential & commercial installations. Installations completed in ID, TX, PA, NJ, NC, VA, and WV. P.O. Box 10, Gum Spring, VA 23065, Phone 804-457-9566, jryago@wwjv.net., www.pvforyou.com

Washington



Mr. Sun Solar: Since 1980, the Northwest's leading solar installer. Over 1,200 projects including solar hot water, solar pool heating, solar attic fans, and on- and off-grid PV systems. Dealer for Sol-Reliant™, The Solar Water Heater Built to Last - OG-300 and Bright Way™ approved. Phone: (888) SOL-RELY (888-765-7359). Web: www.MrSunSolar.com and www.SolReliant.com



Power Trip Energy Corp. "Craft Your Personal Energy Policy" Electrical contractors specializing in renewable energy & a holistic approach to your power needs incorporating complete wiring packages & efficiency analysis. We serve all of Washington, grid-tied & off-grid, residential & commercial. www.powertripenergy.com, (360) 643-3080, info@powertripenergy.com, WA Cont # POWERTE964JN.



Seraphim Energy, Inc. Full service electrical contractor serving the Columbia River Watershed. We specialize in on and off grid wind, sun and water powered systems, meeting all your design, installation and procurement needs. From 100W to 100GW, plug into Seraphim Energy. WA# SERAPEC971MG, 800.265.6288, www.seraphimenergy.com, re@seraphimenergy.com



SolarWind Energy Systems, LLC P.O. Box 1234, Okanogan, WA 98840 (509) 422-5309 www.solar-wind.us WA Cont. # SOLARES983RQ. Serving Eastern WA & Northern ID grid-tied & off-grid RE systems. Solar PV, wind, solar hot water, remote stock watering. Design, installation, service, maint. Solar Energy International (SEI) trained. Lic. & bonded. bclark@solar-wind.us or jmartin@solar-wind.us

Wisconsin



Great Northern Solar, In business since 1988. NABCEP certified. "Waking the Northland to renewable energy & sustainable living!" We install PV, wind and microhydro systems. Large focus on education—workshops on residential and commercial installations available. MREA instructor. Chris LaForge at 715 774-3374, email: gosolar@cheqnet.net 77480 Evergreen Rd Ste #1 Port Wing, 54865

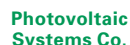

Photovoltaic Systems Co., since 1980 we have been designing, installing and servicing solar electric systems statewide in WI. NABCEP Certified Installer, Xantrex certified dealer & authorized service cntr.; MREA instructor teaching basic thru advanced PV systems workshops. James Kerbel 7910 Hwy 54 Amherst WI. 54406 715-824-2069 PVSOLAR@wi-net.com

FORCEFIELD

www.wondermagnet.com

NdFeB Magnets
Magnet Wire
Books
Weird Science

Needful Things
for the homebrew
renewable energy
enthusiast!



www.otherpower.com

877-944-6247 (toll free)
970-484-7257
2606 W. Vine Dr.
Fort Collins, CO 80521
ff@wondermagnet.com

**MAKE YOUR
ELECTRICITY
FROM SCRATCH!**

SUNELEC.COM

**MODULES & LAMINATES FROM
\$2.90 per WATT!**

*1000's of modules in stock:
EVERGREEN, KYOCERA, SHELL,*

GE, MATRIX

info@sunelec.com

Order Line: 305-536-9917

BackHome MAGAZINE

Your Guide
to Self-Reliant Living

Take control of your own life. Thousands of people have gone BACKHOME to enjoy less complicated, more rewarding lives . . . and you can join them. In each bimonthly issue, find articles on topics such as: Alternative Home-Building Techniques, Organic Gardening, Selecting a Home Business, Living Mortgage Free, and much, much more!



Subscribe to BACKHOME
for just \$21.97 per year.
Call us at 800-992-2546,
write to us at P.O. Box 7011,
Hendersonville, NC 28793
or visit our Web site

www.BackHomeMagazine.com

Battery Watering Made Easy!

PRO-FILL™
ON-BOARD BATTERY WATERING SYSTEM

by **FLOW-RITE**

The Pro-Fill on-board watering system provides the most convenient and accurate means of filling and maintaining proper battery water levels. Several batteries can be filled safely and simultaneously from a remote position without ever having to touch a battery or remove a cap. Pro-Fill's automatic control valves ensure each cell is closed when the precise level is reached.

Distributed By:
JPW

(616) 822-7587

www.janwp.com

sales@janwp.com



AAA Solar Supply 94	Energy Conservation Services 73	North Carolina State University 85	Southwest Solar 25
ABS Alaskan 119	Energy Outfitters 7	Northern Arizona Wind & Sun 95	Southwest Windpower 55
Abundant Renewable Energy 70	Energy Systems & Design 53	Northwest Energy Storage 70	SPS Energy Solutions 79
Adopt a Library 119	Flow-Rite 127	NW RE Festival-Walla Walla 98	Staber Industries, Inc. 73
Advantage Solar 91	Forcefield 127	Offline 114	Steca GmbH 79
AEE Solar Supersource 4	Fronius International 18	OutBack Power Systems IBC	Sun Electronics 113, 127
Affordable Solar 35	Gorilla Vehicles 91	Pennsylvania RE Festival 100	Sun Frost 94
All Battery Sales & Service 79	Got Sun? Go Solar book 107	Permaculture Credit Union 114	Sun Pumps 25
Alternative Energy Store 11	Green & Solar Building Oregon 101	Planetary Systems Inc 78	Sun Spot Solar 121
Alternative Power & Machine 53	Green Festivals 100	Powertech Solar 60	SunDanzer 103
Apollo Solar 49	Grenzone 71	Pulse Genetech 90	SunEarth Inc 61
B.Z. Products 48, 107	Harris Hydroelectric 53	Rae Storage Battery Company 107	Sunelco 72
BackHome 127	Heaven's Flame 106	Rainier Yurts 90	SunWize 89
Backwoods Solar Electric Systems 85	Heliodyne 61	Renewable Energy Handbook 41	Surrette Battery 26
Bailey's Inc 94	Home Power Back Issues 115	RightHand Engineering 25	TCT Solar 70
BioShield 77	Home Power CD-ROMs 80	Rocky Mountain Sustainable Living Fair 98	Texas Renewable Energy Roundup 101
Blue Sky Energy Inc 90	Home Power Sub Form 81	San Juan College 121	Thermodyne 71
Bogart Engineering 41	Homepower.com 81	Simmons Handcrafts 106	Thermomax 118
BP Solar OBC	Hutton Solar 71	SMA America Inc 2	Thermomax & Thermo Tech 61
Brand Electronics 91	Hydrocap 103	Solar Converters 49	Trojan Battery 34
BTF Ltd 59, 121	Hydroscreen Co LLC 119	Solar Depot IFC	U.S. Battery 5
Butler Sun Solutions 60	Independent Power Systems 93	Solar Energy International 43, 95	UniRac 115
C. Crane Company 113	Inverter Service Company 78	Solar Pathfinder 84	Vena Engineering 34
Centric Power Group 55	I-Renew Expo 101	Solar Power 2005 Conference 54	Wattsun (Array Tech Inc) 33
CheapestSolar.com (ZAP) 70	KTA Services Inc 113	Solar Wind Works 73	Windstream Power Systems 119
Communities magazine 121	Kyocera Solar Inc 19	Solar1 Welcome Aboard Special 81	Writing for HP 107
Conergy/Dankoff Solar 17	Magnetek 6	Solartrax Power Stations 85	Xantrex 1
Daystar 114	Mike's Windmill Shop 119	Solectria Renewables 84	Zephyr Industries Inc 121
Direct Power & Water Corp 33	Morningstar 72	SolFest 99	Zomeworks 33
Earth Solar 27	MREA Workshops 103	Sol-Reliant 60	
Electric Auto Association 114	North American Board of Certified Energy Practitioners 89	SOL-Solar-On-Line 114	
Electro Automotive 78	North Carolina Small Wind Initiative 106	Southern Energy & Environment Expo 100	
Electron Connection 42			
Energy Alternatives 95			

Coming Next Issue...



Homeowner Ron Nichols' moment in the sun—flipping the switch that starts his solar electricity flowing to the utility grid.

**Mounting & Wiring
a Solar-Electric Array,
Step-by-Step**

**Bright Ideas—
An Introduction to
Daylighting Strategies**

**Beginner's Guide to
Estimating Solar-
Electric System Costs**

home power

The Hands-On Journal of Home Power

From the Ground Up

Step-By-Step

Solar Installation Project p. 28

Keep Your

COOL

Design Solutions to Beat the Heat p. 20

Improving on

The Good Life

The Nearing Homestead Goes Solar p. 36

San Francisco Sunshine

Free Energy Systems in the City p. 12

Plug In Your Prius?

The Future of Hybrid Cars p. 44

Aug/Sep 2005, Issue 108

\$6.95 US • \$10.95 CAN



homepower.com

SOLAR CONTRACTORS: take a good look at



LOWER PRICES



BETTER TECH SUPPORT



REBATE ASSISTANCE



Established 1979

**WE SUPPLY
GRID-TIED AND
OFF-GRID SYSTEMS**

*ONE OF THE LARGEST
INVENTORIES IN THE U.S.*

*PRODUCT DELIVERY
FROM THREE LOCATIONS
TO YOUR JOB SITE*

*PREPACKAGED
ENGINEERED RESIDENTIAL
SYSTEMS*

*DESIGN ASSISTANCE
FOR COMMERCIAL PROJECTS*

*ASSISTANCE WITH
REBATE FILING*

*EXPERIENCED ENGINEERS
AND MASTER TECHNICIANS*

**25 YEARS OF EXPERIENCE
AND STAYING POWER**



*HOMEOWNERS CALL
US FOR THE NAME OF THE
NEAREST SOL-GEN
CONTRACTOR*



HUGE INVENTORY



MORE LOCATIONS



TIMELY DELIVERY



DESIGN ASSISTANCE

SOLAR DEPOT - PETALUMA
1240 HOLM ROAD
PETALUMA, CA 94954
707.766.7727
FAX 707.766.7722
ORDER LINE 800.822.4041

SOLAR DEPOT - SACRAMENTO
8605 FOLSOM BLVD
SACRAMENTO, CA 95826
916.381.0235
FAX 916.381.2603
ORDER LINE 800.321.0101

SOLAR DEPOT - CORONA
1727-A COMMERCE ST.
CORONA, CA 92880
951.737.7652
FAX 909.737.7630
ORDER LINE 800.680.7922



bp solar
Distributor

WWW.SOLARDEPOT.COM



beyond petroleum®

the future
is in our hands



www.bpsolar.us

The OutBack PS1

Grid-tie with Battery Backup Made Easy.

Certified
CEC Efficiency:

91%

Complete Power System

The PS1 includes a 3kW grid-tie inverter, battery charger, AC transfer switch, MPPT controller, ground fault protection, disconnects, manual bypass, load breakers and all internal wiring.

High Performance

The PS1's power production is comparable to other's batteryless PV inverter systems, but it provides the benefit of backup power during utility outages from both the PV array and from maintenance free sealed batteries - day or night.

Easy To Install

The PS1 comes prewired, tested, ready to go. All battery and inverter cables are included. Even the mounting holes are located on 16 inch centers to save time.

Adaptable

The PS1 includes spaces for optional PV sub-array input breakers and AC load output breakers - eliminating the need for additional conduit, wiring and breaker panels in most installations.

Listed and Proven

From the PS1's outdoor rated rainproof enclosure to the ETL listing and standard 5 year warranty - the OutBack PS1 is unmatched in value, ease of use and overall performance.

OutBack
Power Systems

Support your local dealers and installers



19009 62nd Avenue NE, Arlington, WA 98223 USA
Telephone: 360-435-6030 Fax: 360-435-6019
www.outbackpower.com

SUBSCRIBE!

to **HOME POWER** magazine **FAST & EASY** at **www.homepower.com**
or call 800-707-6585, international 541-512-0201, or fax 541-512-0343

Or, complete and mail this form. Enclose payment as a check, money order, or credit card information.
Tape the form closed carefully or use an envelope so your check won't fall out. Allow up to three weeks for your first issue to arrive.

Shipping Information

Name:

Address:

City:

State:

Zip:

Country:

Phone:

E-mail:

(No spam, guaranteed.)

New Subscription

Renewal Subscription

Gift Subscription

Change of Address

Old Zip Code

FREE CD-ROM Include a free copy of the Solar10 CD-ROM with my three-year subscription/renewal.

* Canadian and international orders must be in U.S. funds drawn on a U.S. bank.

\$ Subtotal:

	USA	Canada*	International*
1 Year: 6 issues Save \$19.20 off the newsstand price!	<input type="checkbox"/> \$22.50 Standard <input type="checkbox"/> \$43.00 1st class	<input type="checkbox"/> \$30.00 Standard <input type="checkbox"/> \$43.00 1st class	<input type="checkbox"/> \$30.00 Ground <input type="checkbox"/> Call for price Air
2 Years: 12 issues Save 10% more!	<input type="checkbox"/> \$40.50 Standard <input type="checkbox"/> \$81.50 1st class	<input type="checkbox"/> \$55.50 Standard <input type="checkbox"/> \$81.50 1st class	<input type="checkbox"/> \$55.50 Ground <input type="checkbox"/> Call for price Air
3 Years: 18 issues Save 15% more! & get a FREE CD-ROM	<input type="checkbox"/> \$57.50 Standard <input type="checkbox"/> \$119.00 1st class	<input type="checkbox"/> \$80.00 Standard <input type="checkbox"/> \$119.00 1st class	<input type="checkbox"/> \$80.00 Ground <input type="checkbox"/> Call for price Air

Specials add price to subscription above

Quick Start With your subscription above, get our six most recent back issues sent to you right away.

Quick Start + 1 Quick Start above, PLUS our Solar1—Renewable Energy Basics on CD-ROM sent right away.

CD-ROM Special Subscription, PLUS any selection from our CD-ROM library.

Enter number of the Solar CD-ROM to add to special. 1 through 10 currently available.

	USA	Canada*	International*
<input type="checkbox"/> Add \$27.50 to your subtotal above	<input type="checkbox"/> Add \$35.00 to your subtotal above	<input type="checkbox"/> Add \$37.00 to your subtotal above	
<input type="checkbox"/> Add \$46.50 to your subtotal above	<input type="checkbox"/> Add \$54.00 to your subtotal above	<input type="checkbox"/> Add \$56.00 to your subtotal above	
<input type="checkbox"/> Add \$21.00 to your subtotal above	<input type="checkbox"/> Add \$22.00 to your subtotal above	<input type="checkbox"/> Add \$23.00 to your subtotal above	

\$ Additional:

Subscription cost plus cost of special

\$ Total:

HP 108

Billing Information if different from above

Name:

Address:

City:

State:

Zip:

Country:

Phone:

E-mail:

(No spam, guaranteed.)

Payment Information

Check Enclosed*

Visa

MasterCard

American Express

Discover

Card Number:

Expiration Date:

Signature:

CSC Number:**

\$ Total:

* Make checks or money orders payable to Home Power magazine.

**The last 3 or 4 digit number on the signature strip on the back of your card. (On the front of American Express cards.)

Reader Feedback Survey

Your answers to the following optional questions give us important insight into what you'd like from *Home Power* in the months and years to come. We depend on your input to help us deliver the information readers need most. Thanks in advance.

In the past three years, I've browsed/read ___ issues of *Home Power*.

- 1 to 3
- 4 to 10
- 11 or more

In terms of renewable energy, I'd describe myself as:

- Unconvinced, but curious
- Still learning what's what
- Ready to start shopping
- Building on my existing system(s)
- An RE professional and user

I value the following *Home Power* coverage...

None Some Lots

- | | | | |
|--------------------------------------------------------|--------------------------|--------------------------|--------------------------|
| Product pricing, comparison, reviews, and selection | <input type="checkbox"/> | <input type="checkbox"/> | <input type="checkbox"/> |
| Detailed instruction on how to do things myself | <input type="checkbox"/> | <input type="checkbox"/> | <input type="checkbox"/> |
| Explanations of how various technologies work | <input type="checkbox"/> | <input type="checkbox"/> | <input type="checkbox"/> |
| Real-world examples of renewable energy systems in use | <input type="checkbox"/> | <input type="checkbox"/> | <input type="checkbox"/> |

I value coverage of the following subjects...

None Some Lots

- | | | | |
|------------------------------|--------------------------|--------------------------|--------------------------|
| Domestic electricity | <input type="checkbox"/> | <input type="checkbox"/> | <input type="checkbox"/> |
| Domestic water heating | <input type="checkbox"/> | <input type="checkbox"/> | <input type="checkbox"/> |
| Home heating & cooling | <input type="checkbox"/> | <input type="checkbox"/> | <input type="checkbox"/> |
| Energy efficiency steps | <input type="checkbox"/> | <input type="checkbox"/> | <input type="checkbox"/> |
| Home design & green building | <input type="checkbox"/> | <input type="checkbox"/> | <input type="checkbox"/> |
| Transportation | <input type="checkbox"/> | <input type="checkbox"/> | <input type="checkbox"/> |

I value the following regular features...

None Some Lots

- | | | | |
|-------------------------------------------|--------------------------|--------------------------|--------------------------|
| From Us to You | <input type="checkbox"/> | <input type="checkbox"/> | <input type="checkbox"/> |
| Code Corner, John Wiles | <input type="checkbox"/> | <input type="checkbox"/> | <input type="checkbox"/> |
| Independent Power Providers, Don Loweburg | <input type="checkbox"/> | <input type="checkbox"/> | <input type="checkbox"/> |
| Power Politics, Michael Welch | <input type="checkbox"/> | <input type="checkbox"/> | <input type="checkbox"/> |
| Word Power, Ian Woofenden | <input type="checkbox"/> | <input type="checkbox"/> | <input type="checkbox"/> |
| Home & Heart, Kathleen Jarschke-Schultze | <input type="checkbox"/> | <input type="checkbox"/> | <input type="checkbox"/> |
| Ozonal Notes, Richard Perez | <input type="checkbox"/> | <input type="checkbox"/> | <input type="checkbox"/> |
| "What the Heck?" | <input type="checkbox"/> | <input type="checkbox"/> | <input type="checkbox"/> |
| (Reader) Letters | <input type="checkbox"/> | <input type="checkbox"/> | <input type="checkbox"/> |
| Q&A | <input type="checkbox"/> | <input type="checkbox"/> | <input type="checkbox"/> |
| Happenings | <input type="checkbox"/> | <input type="checkbox"/> | <input type="checkbox"/> |

Comments

Your additional comments about *Home Power* past, present, and future...

It's okay to print my comments as a letter to *Home Power*.

Fold Here

Return Address:



NO POSTAGE
NECESSARY
IF MAILED
IN THE
UNITED STATES

BUSINESS REPLY MAIL
FIRST-CLASS MAIL PERMIT NO. 49 ASHLAND OR
POSTAGE WILL BE PAID BY ADDRESSEE



HOME POWER
PO BOX 520
ASHLAND OR 97520-9903

